

Axial piston variable motor

A6VM Series 63

Asia-Pacific

RE-P 91604

Edition: 05.2016

Replaces: 06.2012



- ▶ All-purpose high pressure motor
- ▶ Sizes 28 to 200:
 - Nominal pressure 400 bar
 - Maximum pressure 450 bar
- ▶ Sizes 250 to 1000:
 - Nominal pressure 350 bar
 - Maximum pressure 400 bar
- ▶ Open and closed circuits

Features

- ▶ Robust motor with long service life
- ▶ Approved for very high rotational speeds
- ▶ High control range (can be swiveled to zero)
- ▶ High torque
- ▶ Variety of controls
- ▶ Optionally with flushing and boost-pressure valve mounted
- ▶ Optionally with integrated or mounted counterbalance valve
- ▶ Bent-axis design

Contents

Type code	2
Hydraulic fluids	5
Bearing	6
Shaft seal	6
Working pressure range	7
Technical data	8
Technical data	9
HD – Proportional control, hydraulic	11
EP – Proportional control, electric	15
HZ – Two-point control, hydraulic	19
EZ – Two-point control, electric	21
HA – Automatic high-pressure related control	23
DA – Automatic control, speed related	29
Electric travel direction valve (for DA, HA.R)	31
Dimensions, sizes 28 to 200	32
Dimensions, sizes 250 to 1000	60
Connector for solenoids	72
Flushing and boost-pressure valve	73
BVD and BVE counterbalance valve	75
Swivel angle indicator	78
Speed sensor	79
Installation instructions	80
Project planning notes	82
Safety instructions	83

01	02	03	04	05	06	07	08	09	10	11	12	13	14	15	16	17	18	19	20	
	A6V		M					/	63	W		-	V						-	

Overrides for the HA1 and HA2 controls		28	55	80	107	140	160	200	250	355	500	1000	
08	Without override (without code)	•	•	•	•	•	•	•	•	•	•	•	
	Hydraulic override, remote control, proportional	•	•	•	•	•	•	•	•	•	•	•	T
	Remote control electric override, two-point	$U = 12\text{ V}$	•	•	•	•	•	•	-	-	-	-	U1
		$U = 24\text{ V}$	•	•	•	•	•	•	•	-	-	-	U2
	Electric override + travel direction valve, electric	$U = 12\text{ V}$	•	•	•	•	•	•	-	-	-	-	R1
		$U = 24\text{ V}$	•	•	•	•	•	•	•	-	-	-	R2

Series		09	Series 6, index 3	63
---------------	--	----	-------------------	----

Direction of rotation		10	Viewed on drive shaft, bidirectional	W
------------------------------	--	----	--------------------------------------	---

Setting ranges for displacement³⁾		28	55	80	107	140	160	200	250	355	500	1000	
11	$V_{g\ min} = 0\text{ to }0.7\ V_{g\ max}$	•	•	•	•	•	•	•	-	-	-	-	
	$V_{g\ min} = 0\text{ to }0.4\ V_{g\ max}$ $V_{g\ max} = V_{g\ max}\text{ to }0.8\ V_{g\ max}$	-	-	-	-	-	-	-	•	•	•	•	1
	$V_{g\ min} > 0.4\ V_{g\ max}\text{ to }0.8\ V_{g\ max}$ $V_{g\ max} = V_{g\ max}\text{ to }0.8\ V_{g\ max}$	-	-	-	-	-	-	-	•	•	•	•	2

Sealing material		12	FKM (fluoroelastomer)	V
-------------------------	--	----	-----------------------	---

Drive shaft		28	55	80	107	140	160	200	250	355	500	1000	
13	Splined shaft DIN 5480	•	•	•	•	-	•	•	-	-	-	-	A
		•	•	•	•	•	•	-	•	•	•	•	Z
	Parallel keyed shaft DIN 6885	-	-	-	-	-	-	-	•	•	•	•	P

Mounting flange		28	55	80	107	140	160	200	250	355	500	1000	
14	ISO 3019-2	4-hole	•	•	•	•	•	•	•	-	-	-	B
		8-hole	-	-	-	-	-	-	-	-	•	•	•

Port plate for working line⁴⁾		28	55	80	107	140	160	200	250	355	500	1000			
15	SAE working ports A and B at rear	01	0	•	•	•	•	•	•	•	•	•	010		
			7	•	•	•	•	•	•	•	•	•	•	017	
	SAE working ports A and B lateral, opposite	02	0	•	•	•	•	•	•	•	•	•	020		
			7	•	•	•	•	•	•	•	•	•	•	027	
	SAE working ports A and B lateral, opposite + rear	15	0	-	-	-	-	-	-	•	•	•	•	150	
			8	-	-	-	-	-	-	-	-	-	-	-	
	Port plate with 1-stage pres- sure-relief valves for mounting a counterbalance valve ⁵⁾	for BVD20	37	0	-	-	-	•	-	-	-	-	-	370	
				8	-	-	-	•	-	-	-	-	-	-	378
		for BVD20/BVD25	38	0	-	•	•	•	•	•	• ⁶⁾	-	-	-	380
				8	-	•	•	•	•	•	•	• ⁶⁾	-	-	-
	for BVE	38	0	-	-	-	•	•	•	•	-	-	-	380	
			8	-	-	-	•	•	•	•	-	-	-	-	388

Valve (see page 73 and 77)

Without valve	0
Flushing and boost-pressure valve, mounted	7
Counterbalance valve mounted ⁷⁾	8

• = Available ◦ = On request - = Not available

3) Please specify exact settings for $V_{g\ min}$ and $V_{g\ max}$ in plain text when ordering: $V_{g\ min} = \dots\text{ cm}^3$, $V_{g\ max} = \dots\text{ cm}^3$

4) Fastening thread, metric

5) Only possible in combination with HD, EP and HA control. Note the restrictions described on page 75.

6) Counterbalance valve MHB32, please contact us.

7) Type code for counterbalance valve to be quoted separately in accordance with data sheet 95522 – BVD or 95525 – BVE. Note the restrictions described on page 75.

4 **A6VM Series 63** | Axial piston variable motor
Type code

01	02	03	04	05	06	07	08	09	10	11	12	13	14	15	16	17	18	19	20	
	A6V		M					/	63	W		-	V						-	

Speed sensor (see page 79)

		28	55	80	107	140	160	200	250	355	500	1000 ⁸⁾	
16	Without speed sensor (without code)	●	●	●	●	●	●	●	●	●	●	●	0
	Prepared for HDD speed sensor	▲	▲	▲	▲	▲	▲	▲	●	●	●	-	F
	HDD speed sensor mounted ⁹⁾	▲	▲	▲	▲	▲	▲	▲	●	●	●	-	H
	Prepared for DSM/DSA speed sensor	●	●	●	●	●	●	●	-	-	-	-	U
	DSM/DSA speed sensor mounted ⁹⁾	●	●	●	●	●	●	●	-	-	-	-	V

Swivel angle sensor (see page 78)

		28	55	80	107	140	160	200	250	355	500	1000	
17	Without swivel angle sensor	●	●	●	●	●	●	●	●	●	●	-	
	Optical swivel angle sensor	-	-	-	-	-	-	-	●	●	●	●	V
	Electric swivel angle sensor	-	-	-	-	-	-	-	●	●	●	●	E

Connector for solenoids (see page 72)

		28 to 200				250 to 1000				
18	Without connector (without solenoid, with hydraulic control only) (sizes 250 to 1000)	●				-				0
	DEUTSCH molded connector, 2-pin – without suppressor diode	●				-				P
	HIRSCHMANN connector – without suppressor diode	-				●				

Beginning of control

		28	55	80	107	140	160	200	250	355	500	1000	
19	At $V_{g\ min}$ (standard for HA)	●	●	●	●	●	●	●	●	●	●	●	A
	At $V_{g\ max}$ (standard for HD, HZ, EP, EZ, DA)	●	●	●	●	●	●	●	●	●	●	●	B

Standard / special version

20	Standard version	
	Standard version with installation variants, e.g. T ports open and closed contrary to standard	-Y
	Special version	-S

● = Available ○ = On request ▲ = Not for new projects - = Not available

Notice

- ▶ Note the project planning notes on page 82.
- ▶ In addition to the type code, please specify the relevant technical data when placing your order.

⁸⁾ Please contact us.
⁹⁾ Specify type code separately for sensor in accordance with data sheet 95132 – DSM or 95133 – DSA, 95135 – HDD and observe the requirements for the electronics.

Hydraulic fluids

The A6VM variable motor is designed for operation with HLP mineral oil according to DIN 51524. Application instructions and requirements for hydraulic fluids should be taken from the following data sheets before the start of project planning:

- ▶ 90220: Hydraulic fluids based on mineral oils and related hydrocarbons
- ▶ 90221: Environmentally acceptable hydraulic fluids
- ▶ 90222: Fire-resistant, water-free hydraulic fluids (HFDR/HFDU)
- ▶ 990223: Fire-resistant, water-containing hydraulic fluids (HFC, HFB)
- ▶ 90225: Axial piston units for operation with water-free and water-containing fire-resistant hydraulic fluids (HFDR, HFDU, HFB, HFC).

The variable motor A6VM is not suitable for operation with HFA fluids. If operating with HFB-, HFC- and HFD or environmentally acceptable hydraulic fluids, the limitations regarding technical data or other seals must be observed.

Viscosity and temperature of hydraulic fluids

	Viscosity	Temperature	Comment
Cold start ¹⁾	$v_{\max} \leq 1600 \text{ mm}^2/\text{s}$	$\theta_{\text{St}} \geq -40 \text{ }^\circ\text{C}$	$t \leq 3 \text{ min}$, $n \leq 1000 \text{ rpm}$, without load $p \leq 50 \text{ bar}$
	Permissible temperature difference	$\Delta T \leq 25 \text{ K}$	between axial piston unit and hydraulic fluid in the system
Warm-up phase	$v = 1600 \text{ to } 400 \text{ mm}^2/\text{s}$	$\theta = -40 \text{ }^\circ\text{C to } -25 \text{ }^\circ\text{C}$	at $p \leq 0.7 \times p_{\text{nom}}$, $n \leq 0.5 \times n_{\text{nom}}$ and $t \leq 15 \text{ min}$
Continuous operation	$v = 400 \text{ to } 10 \text{ mm}^2/\text{s}$		This corresponds, for example on the VG 46, to a temperature range of $+5 \text{ }^\circ\text{C to } +85 \text{ }^\circ\text{C}$ (see selection diagram)
		$\theta = -25 \text{ }^\circ\text{C to } +103 \text{ }^\circ\text{C}$	Note the permissible temperature range of the shaft seal measured at port T ($\Delta T = \text{approx. } 12 \text{ K}$ between the bearing/shaft seal and port T)
	$v_{\text{opt}} = 36 \text{ to } 16 \text{ mm}^2/\text{s}$		Range of optimum operating viscosity and efficiency
Short-term operation	$v_{\min} \geq 7 \text{ mm}^2/\text{s}$		$t < 3 \text{ min}$, $p < 0.3 \times p_{\text{nom}}$

1) For application cases below $-25 \text{ }^\circ\text{C}$, an NBR shaft seal is required (permissible temperature range $-40 \text{ }^\circ\text{C to } +90 \text{ }^\circ\text{C}$).

▼ Selection diagram

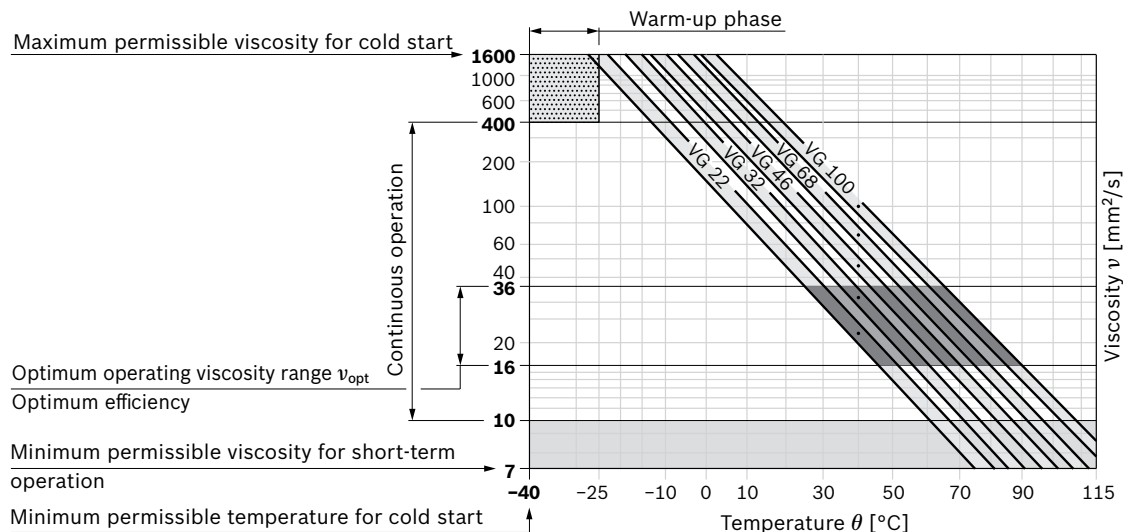

Notes on selection of hydraulic fluid

The hydraulic fluid should be selected such that the operating viscosity in the operating temperature range is within the optimum range (v_{opt} see selection diagram).

Notice

At no point of the component may the temperature be higher than $115 \text{ }^\circ\text{C}$. The temperature difference specified in the table is to be taken into account when determining the viscosity in the bearing.

If the above conditions cannot be maintained due to extreme operating parameters, we recommend the use of a flushing and boost-pressure valve (see page 73).

Filtration of the hydraulic fluid

Finer filtration improves the cleanliness level of the hydraulic fluid, which increases the service life of the axial piston unit. A cleanliness level of at least 20/18/15 is to be maintained according to ISO 4406.

At very high hydraulic fluid temperatures (90 °C to maximum 103 °C, measured at port **T**), a cleanliness level of at least 19/17/14 according to ISO 4406 is necessary.

Effect of case pressure on beginning of control

An increase in case pressure affects the beginning of control of the variable motor when using the following control options:

- ▶ HD, HA.T3: increase
- ▶ HD, EP, HA, HA.T (Sizes 250 to 1000): increase
- ▶ DA: decrease

With the following settings, an increase in case pressure will have no effect on the beginning of control:

HA.R and HA.U, EP, HA

The factory settings for the beginning of control are made at $p_{abs} = 2$ bar (sizes 28 to 200) and $p_{abs} = 1$ bar (sizes 250 to 1000) case pressure.

Flow direction

Direction of rotation, viewed on drive shaft	
clockwise	counter-clockwise
A to B	B to A

Bearing

- ▶ Long-life bearing, NG250-1000
- ▶ Flushing (flushing flow table with blue section), sizes 250 to 1000

For long service life and use with HF hydraulic fluids. Identical external dimensions as motor with standard bearings. Subsequent conversion to long-life bearings is possible.

Flushing flow (recommended)

Size	250	355	500	1000
$q_{v \text{ flush}}$ [l/min]	10	16	16	16

To reduce the leakage temperature, external case flushing is possible via port **U** or internally via a flushing valve.

Shaft seal

Permissible pressure loading

The service life of the shaft seal is influenced by the rotational speed of the axial piston unit and the leakage pressure in the housing (case pressure). Momentary ($t < 0.1$ s) pressure peaks of up to 10 bar are allowed. Case pressures of a continuous 2 bar maximum are permitted to be able to utilize the entire speed range. Higher case pressures are permissible at lower rotational speeds (see diagram).

The service life of the shaft seal decreases with increasing frequency of pressure peaks and increasing mean differential pressure.

The case pressure must be equal to or higher than the ambient pressure.

▼ Sizes 28 to 200

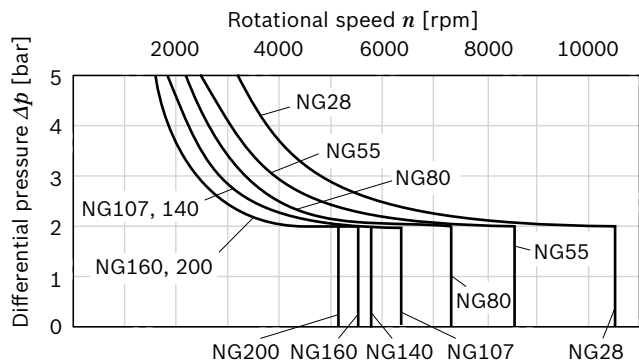

▼ Sizes 250 to 1000

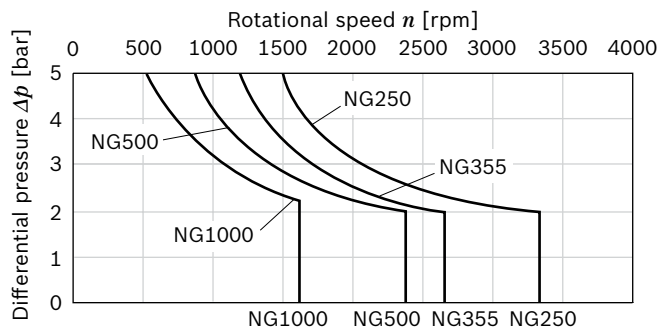

The FKM shaft seal ring may be used for leakage temperatures from -25 °C to +115 °C. For application cases below -25 °C, an NBR shaft seal is required (permissible temperature range: -40 °C to +90 °C).

Working pressure range

Pressure at working port A or B		Definition
Nominal pressure p_{nom}	NG28 to 200 400 bar	The nominal pressure corresponds to the maximum design pressure.
	NG250 to 1000 350 bar	
Maximum pressure p_{max}	NG28 to 200 450 bar	The maximum pressure corresponds to the maximum working pressure within the single operating period. The sum of the single operating periods must not exceed the total operating period.
	NG250 to 1000 400 bar	
Single operating period	10 s	
Total operating period	300 h	
Minimum pressure (high-pressure side)	25 bar	Minimum pressure at the high-pressure side (A or B) required to prevent damage to the axial piston unit.
Minimum pressure – operation as a pump (inlet)	See diagram below	To avoid damage to the axial piston motor during operation as a pump (change of the high-pressure side at constant direction of rotation, e.g. during braking processes) a minimum pressure has to be ensured at the working port (inlet). The minimum required pressure is dependent on the rotational speed and displacement of the axial piston unit (see characteristic curve).
Summation pressure p_{Su} (pressure A + pressure B)	700 bar	The summation pressure is the sum of the pressures at the ports for the working lines (A and B)
Rate of pressure change $R_{A\ max}$	with built-in pressure relief valve	Maximum permissible rate of pressure build-up and reduction during a pressure change across the entire pressure range.
	without pressure relief valve	
		16000 bar/s

▼ Rate of pressure change $R_{A\ max}$

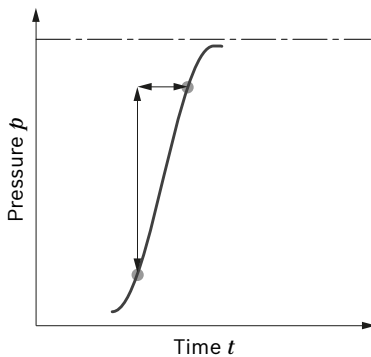

▼ Pressure definition

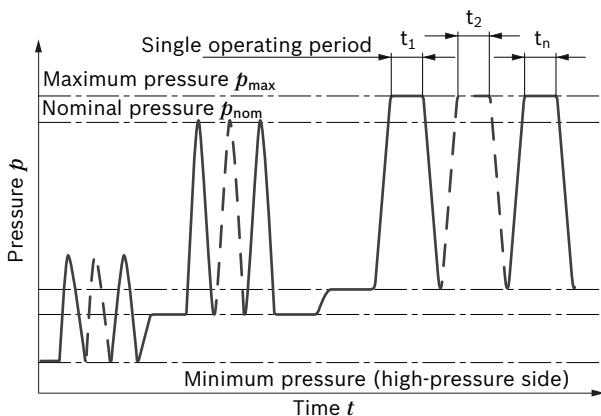

Total operating period = $t_1 + t_2 + \dots + t_n$

▼ Minimum pressure – operation as a pump (inlet)

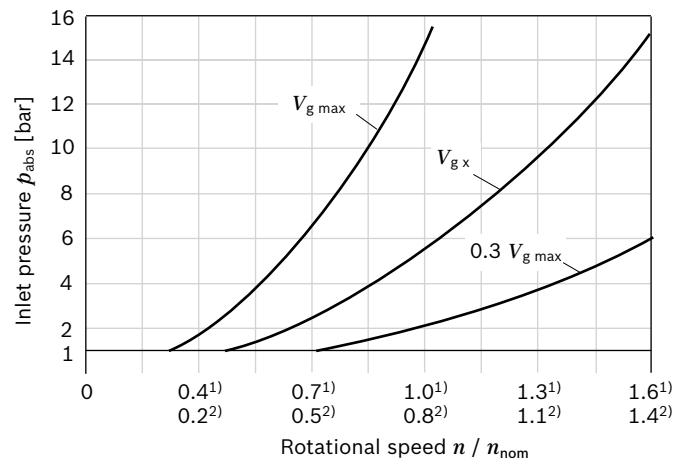

This diagram is only valid for the optimum viscosity range of $\nu_{opt} = 36$ to $16\text{ mm}^2/\text{s}$.

If the above mentioned conditions cannot be ensured please contact us.

Notice

Working pressure range valid when using hydraulic fluids based on mineral oils. Values for other hydraulic fluids, please contact us.

1) For sizes 28 to 200
2) For sizes 250 to 1000

Technical data

Size		NG	28	55	80	107	140	160	
Geometric displacement, per revolution ¹⁾		$V_{g \max}$	cm ³	28.1	54.8	80	107	140	160
		$V_{g \min}$	cm ³	0	0	0	0	0	0
		$V_{g x}$	cm ³	18	35	51	68	88	61
Maximum rotational speed ²⁾ (while adhering to the maximum permissible inlet flow)	at $V_{g \max}$	n_{nom}	rpm	5550	4450	3900	3550	3250	3100
	at $V_g < V_{g x}$ (see diagram on page 9)	n_{max}	rpm	8750	7000	6150	5600	5150	4900
	where $V_{g 0}$	n_{max}	rpm	10450	8350	7350	6300	5750	5500
Inlet flow ³⁾	at n_{nom} and $V_{g \max}$	$q_{v \max}$	l/min	156	244	312	380	455	496
Torque ⁴⁾	at $V_{g \max}$ and $\Delta p = 400$ bar	T	Nm	179	349	509	681	891	1019
	at $V_{g \max}$ and $\Delta p = 350$ bar	T	Nm	157	305	446	596	778	891
Rotary stiffness	$V_{g \max}$ to $V_g/2$	c_{min}	kNm/rad	6	10	16	21	34	35
	$V_g/2$ to 0 (interpolated)	c_{min}	kNm/rad	18	32	48	65	93	105
Moment of inertia for rotary group		J_{TW}	kgm ²	0.0014	0.0042	0,008	0.0127	0.0207	0.0253
Maximum angular acceleration		α	rad/s ²	47000	31500	24000	19000	11000	11000
Case volume		V	l	0.5	0.75	1.2	1.5	1.8	2.4
Weight approx.		m	kg	16	28	36	46	61	62

Size		NG	200	250	355	500	1000	
Geometric displacement, per revolution ¹⁾		$V_{g \max}$	cm ³	200	250	355	500	1000
		$V_{g \min}$	cm ³	0	0	0	0	0
		$V_{g x}$	cm ³	76	205	300	417	1000
Maximum rotational speed ²⁾ (while adhering to the maximum permissible inlet flow)	at $V_{g \max}$	n_{nom}	rpm	2900	2700	2240	2000	1600
	at $V_g < V_{g x}$ (see diagram on page 9)	n_{max}	rpm	4600	3300	2650	2400	1600
	where $V_{g 0}$	n_{max}	rpm	5100	3300	2650	2400	1600
Inlet flow ³⁾	at n_{nom} and $V_{g \max}$	$q_{v \max}$	l/min	580	675	795	1000	1600
Torque ⁴⁾	at $V_{g \max}$ and $\Delta p = 400$ bar	T	Nm	1273	-	-	-	-
	at $V_{g \max}$ and $\Delta p = 350$ bar	T	Nm	1114	1391	1978	2785	5571
Rotary stiffness	$V_{g \max}$ to $V_g/2$	c_{min}	kNm/rad	44	60	75	115	281
	$V_g/2$ to 0 (interpolated)	c_{min}	kNm/rad	130	181	262	391	820
Moment of inertia for rotary group		J_{TW}	kgm ²	0.0353	0,061	0,102	0,178	0.55
Maximum angular acceleration		α	rad/s ²	11000	10000	8300	5500	4000
Case volume		V	l	2.7	3.00	5.0	7.0	16.0
Weight approx.		m	kg	78	100	170	210	430

Speed range

The minimum rotational speed n_{min} is not restricted. Please consult us regarding applications requiring uniformity of the rotatory motion at low speeds.

1) The minimum and maximum displacement can be steplessly adjusted, see type code on page 3. (standard setting for sizes 250 to 1000 if ordering code is missing:

$$V_{g \min} = 0.2 \times V_{g \max}, V_{g \max} = V_{g \max}$$

2) The values are applicable:

- for the optimum viscosity range from $\nu_{\text{opt}} = 36$ to 16 mm²/s
- with hydraulic fluid based on mineral oils

3) Observe limitation of displacement due to counterbalance valve (page 75)

4) Torque without radial force, with radial force, see page 10.

Notice

- ▶ Theoretical values, without efficiency and tolerances; values rounded
- ▶ Operation above the maximum values or below the minimum values may result in a loss of function, a reduced service life or in the destruction of the axial piston unit. Other permissible limit values, such as speed variation, reduced angular acceleration as a function of the frequency and the permissible angular acceleration at start (lower than the maximum angular acceleration) can be found in data sheet 90261.

Technical data

▼ Permissible displacement in relation to rotational speed

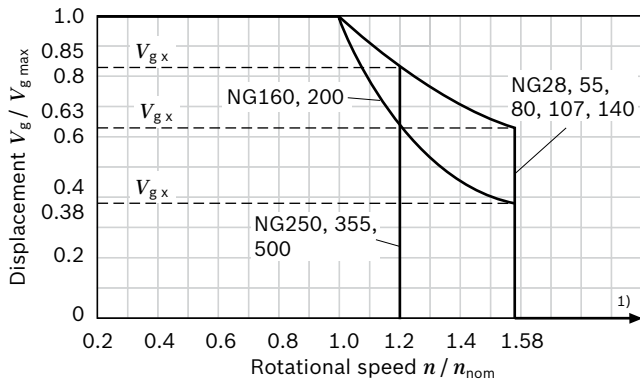

Determining the operating characteristics		
Inlet flow	$q_v = \frac{V_g \times n}{1000 \times \eta_v}$	[l/min]
Rotational speed	$n = \frac{q_v \times 1000 \times \eta_v}{V_g}$	[rpm]
Torque	$T = \frac{V_g \times \Delta p \times \eta_{hm}}{20 \times \pi}$	[Nm]
Power	$P = \frac{2 \pi \times T \times n}{60000} = \frac{q_v \times \Delta p \times \eta_t}{600}$	[kW]

Key

- V_g Displacement per revolution [cm³]
- Δp Differential pressure [bar]
- n Rotational speed [rpm]
- η_v Volumetric efficiency
- η_{hm} Hydraulic-mechanical efficiency
- η_t Total efficiency ($\eta_t = \eta_v \times \eta_{hm}$)

1) Values in this range on request

Permissible radial and axial forces of the drive shafts

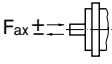
Size	NG	28	28	55	55	80	80	107	107	140	160	160		
Drive shaft	Code	A	Z	A	Z	A	Z	A	Z	Z	A	Z		
	Splined shaft		W30	W25	W35	W30	W40	W35	W45	W40	W45	W45		
	Keyed shaft	∅	mm	–	–	–	–	–	–	–	–	–		
Maximum radial force at distance a (from shaft collar)		$F_{q \max}$	N	4838	6436	8069	7581	10283	10266	12215	13758	15982	16435	18278
		a	mm	17.5	14.0	20.0	17.5	22.5	20.0	25.0	22.5	25.0	27.5	25.0
Maximum torque at $F_{q \max}$		$T_{q \max}$	Nm	179	179	349	281	509	444	681	681	891	1019	1019
Maximum differential pressure at $V_{g \max}$ and $F_{q \max}$		$\Delta p_{q \max}$	bar	400	400	400	322	400	349	400	400	400	400	400
Maximum axial force at standstill or depressurized operation		$+ F_{ax \max}$	N	0	0	0	0	0	0	0	0	0	0	0
		$- F_{ax \max}$	N	315	315	500	500	710	710	900	900	1030	1120	1120
Permissible axial force per bar working pressure		$+ F_{ax \text{ perm/bar}}$	N/bar	4.6	4.6	7.5	7.5	9.6	9.6	11.3	11.3	13.3	15.1	15.1

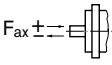
Size	NG	200	250	250	355	355	500	500	1000	1000		
Drive shaft	Code	A	Z	P	Z	P	Z	P	Z	P		
	Splined shaft		W50	W50	–	W60	–	W70	–	W90	–	
	Keyed shaft	∅	mm	–	–	50	–	60	–	70	–	90
Maximum radial force at distance a (from shaft collar)		$F_{q \max}$	N	20532	1200 ¹⁾	1200 ¹⁾	1500 ¹⁾	1500 ¹⁾	1900 ¹⁾	1900 ¹⁾	2600 ¹⁾	2600 ¹⁾
		a	mm	27.5	41.0	41.0	52.5	52.5	52.5	52.5	67.5	67.5
Maximum torque at $F_{q \max}$		$T_{q \max}$	Nm	1273	2)	2)	2)	2)	2)	2)	2)	2)
Maximum differential pressure at $V_{g \max}$ and $F_{q \max}$		$\Delta p_{q \max}$	bar	400	2)	2)	2)	2)	2)	2)	2)	2)
Maximum axial force at standstill or depressurized operation		$+ F_{ax \max}$	N	0	0	0	0	0	0	0	0	0
		$- F_{ax \max}$	N	1250	1200	1200	1500	1500	1900	1900	2600	2600
Permissible axial force per bar working pressure		$+ F_{ax \text{ perm/bar}}$	N/bar	17.0	2)	2)	2)	2)	2)	2)	2)	2)

Effect of radial force F_q on the service life of bearings

By selecting a suitable direction of radial force F_q , the load on the bearings, caused by the internal rotary group forces can be reduced, thus optimizing the service life of the bearings. Recommended position of mating gear is dependent on direction of rotation. Examples:

▼ **Toothed gear output drive**

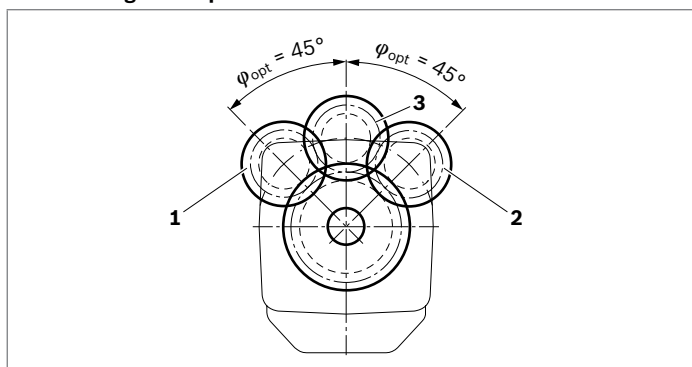

- 1 "Counter-clockwise" rotation. Pressure at port B
- 2 "Clockwise" rotation, pressure at port A
- 3 Bidirectional direction of rotation

Notice

- ▶ The values given are maximum values and do not apply to continuous operation.
- ▶ The permissible axial force in direction $-F_{ax}$ is to be avoided as the lifetime of the bearing is reduced.
- ▶ Special requirements apply in the case of belt drives. Please contact us.

- 1) When at standstill or when axial piston unit working in depressurized conditions. Higher forces are permissible under pressure, please contact us.
- 2) Please contact us.

HD – Proportional control, hydraulic

The proportional hydraulic control provides infinite adjustment of the displacement. The control is proportional to the pilot pressure at port **X**.

HD1, HD2, HD3

- ▶ Beginning of control at $V_{g \max}$ (maximum torque, minimum rotational speed at minimum pilot pressure).
- ▶ End of control at $V_{g \min}$ (minimum torque, maximum permissible rotational speed, at maximum pilot pressure).

Notice

- ▶ Maximum permissible pilot pressure: $p_{St} = 100$ bar
- ▶ The control oil is internally taken out of the high pressure side of the motor (**A** or **B**). For reliable control, a working pressure of at least 30 bar is necessary in **A** (**B**). If a control operation is performed at a working pressure < 30 bar, an auxiliary pressure of at least 30 bar must be applied at port **G** using an external check valve. For lower pressures, please contact us.
Please note that at port **G** up to 450 bar (sizes 28 to 200) or 400 bar (sizes 250 to 1000) can occur.
- ▶ Specify the desired beginning of control in plain text when ordering, e.g.: beginning of control at 10 bar.
- ▶ The beginning of control and the HD-characteristic curve are influenced by case pressure. An increase in the case pressure causes an increase in the beginning of control (see page 7) and thus a parallel displacement of the characteristic curve.
- ▶ A leakage flow of maximum 0.3 l/min can occur at port **X** due to internal leakage (working pressure > pilot pressure). The control is to be suitably configured to avoid an independent build-up of pilot pressure.

Response time damping

The response time damping impacts the pivot behavior of the motor and consequently the machine response speed.

Standard for sizes 28 to 200

HD1, HD2 without damping.

HD.D, HD.E with throttle pin on both sides, symmetrical (see table)

Option for sizes 28 to 200

HD1, HD2, with throttle pin on both sides, symmetrical (see table)

▼ Throttle pin overview

Size	28	55	80	107	140	160	200
Groove size [mm]	0.3	0.45	0.45	0.55	0.55	0.55	0.65

Standard for sizes 250 to 1000

HD1, HD2 and HD3 with orifice ($\varnothing 1.2$ mm)

HD.D, HD.E, HP.G with adjustable response time limiting valve with orifice ($\varnothing 1.2$ mm)

HD1, pilot pressure increase $\Delta p_{St} = 10$ bar

A pilot pressure increase of 10 bar at port **X** will cause a reduction in displacement from $V_{g \max}$ to 0 cm³ (sizes 28 to 200) or from $V_{g \max}$ to 0.2 $V_{g \max}$ (sizes 250 to 1000).

Beginning of control, setting range 2 to 20 bar

Standard setting: beginning of control at 3 bar (end of control at 13 bar)

▼ Characteristic curve

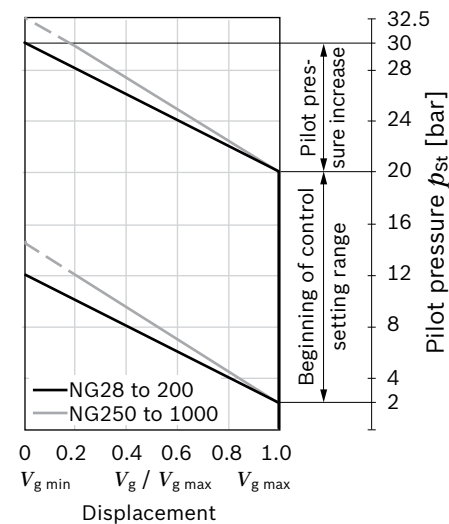

HD2, pilot pressure increase $\Delta p_{St} = 25$ bar

A pilot pressure increase of 25 bar at port **X** results in a reduction in displacement from $V_{g\ max}$ to $0\ cm^3$ (sizes 28 to 200) or from $V_{g\ max}$ to $0.2\ V_{g\ max}$ (sizes 250 to 1000).

Beginning of control, setting range 5 to 35 bar

Standard setting: beginning of control at 10 bar (end of control at 35 bar)

▼ **Characteristic curve**

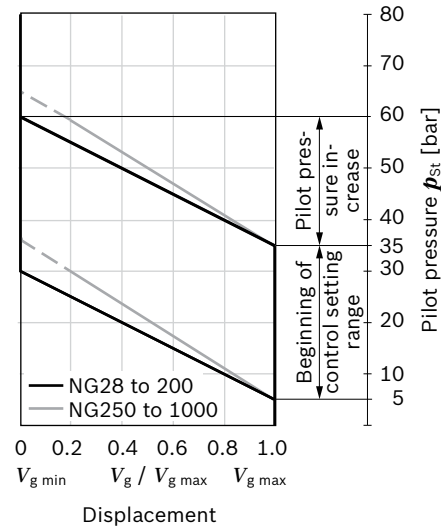

▼ **Circuit diagram HD1, HD2, sizes 28 to 200**

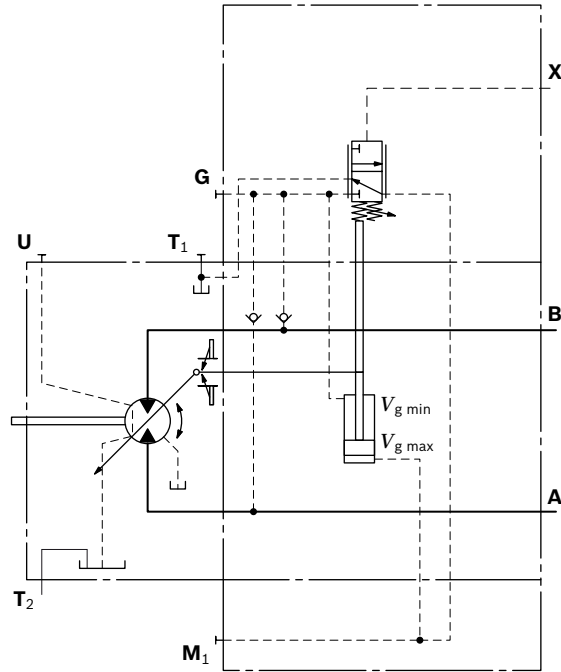

▼ **Circuit diagram HD1, HD2, HD3, sizes 250 to 1000**

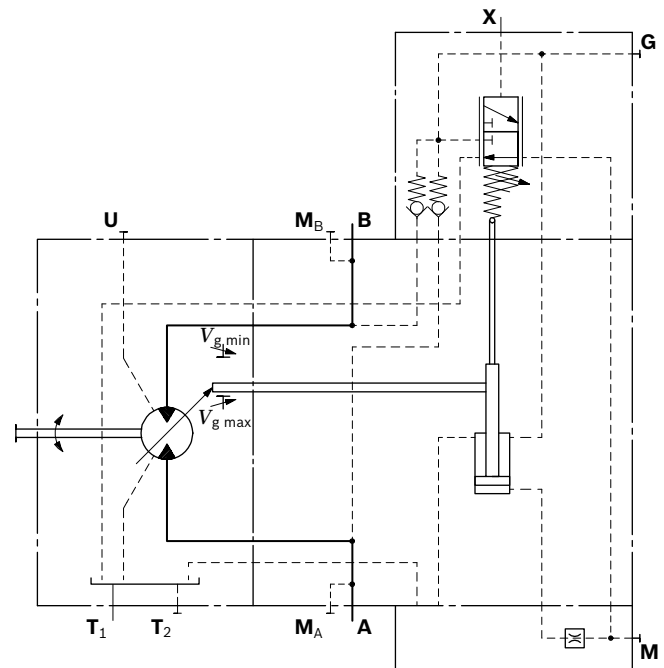

HD3, pilot pressure increase $\Delta p_{St} = 35$ bar

(sizes 250 to 1000)

A pilot pressure increase of 35 bar at port **X** results in a reduction in displacement from $V_{g\ max}$ to $0.2\ V_{g\ max}$.

Beginning of control, setting range 7 to 50 bar

Standard setting: beginning of control at 10 bar (end of control at 45 bar)

▼ **Characteristic curve**

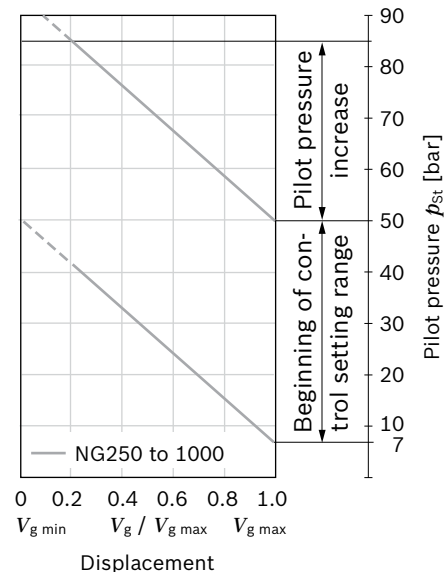

HD.D Pressure control, fixed setting

The pressure control overrides the HD control function. If the load torque or a reduction in motor swivel angle causes the system pressure to reach the setpoint value of the pressure control, the motor will swivel towards a larger angle. The increase in displacement and the resulting reduction in pressure cause the control deviation to decrease. With the increase in displacement the motor develops more torque, while the pressure remains constant.

Sizes 28 to 200:

Setting range of the pressure control valve 80 to 400 bar

Sizes 250 to 1000:

Setting range of the pressure control valve 80 to 350 bar

▼ **Circuit diagram HD.D, sizes 28 to 200**

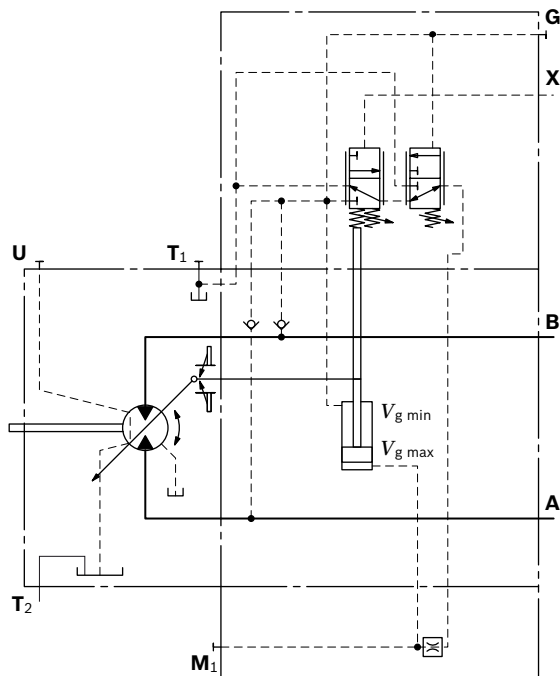

▼ **Circuit diagram HD.D, sizes 250 to 1000**

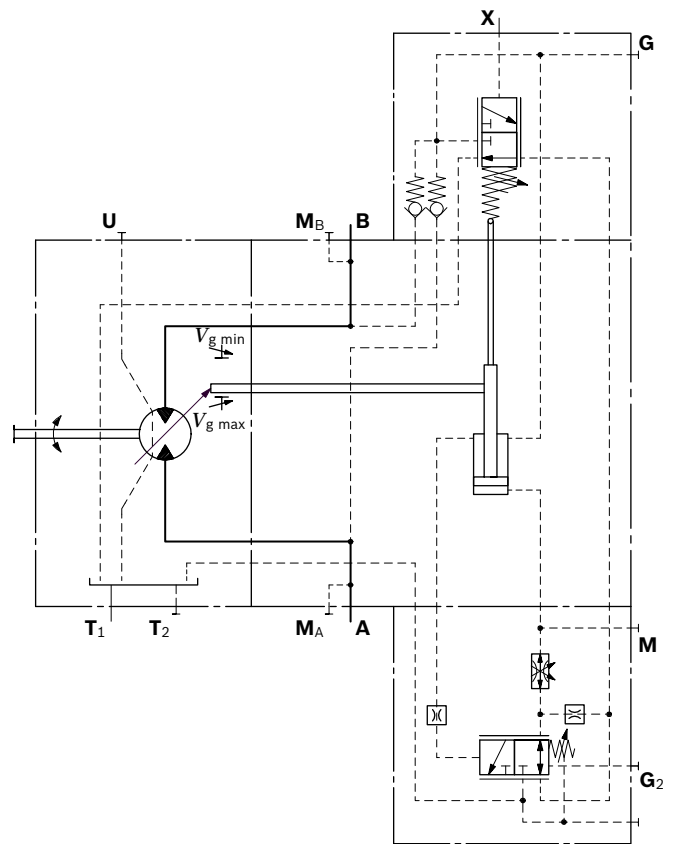

HD.E pressure control, hydraulic override, two-point, sizes 28 to 200

The pressure control setting can be overridden by applying an external pilot pressure at port **G₂**, realizing a 2nd pressure setting.

Necessary pilot pressure at port **G₂**:

$$p_{St} = 20 \text{ to } 50 \text{ bar}$$

When ordering, please specify the 2nd pressure setting in plain text.

▼ **Circuit diagram HD.E**

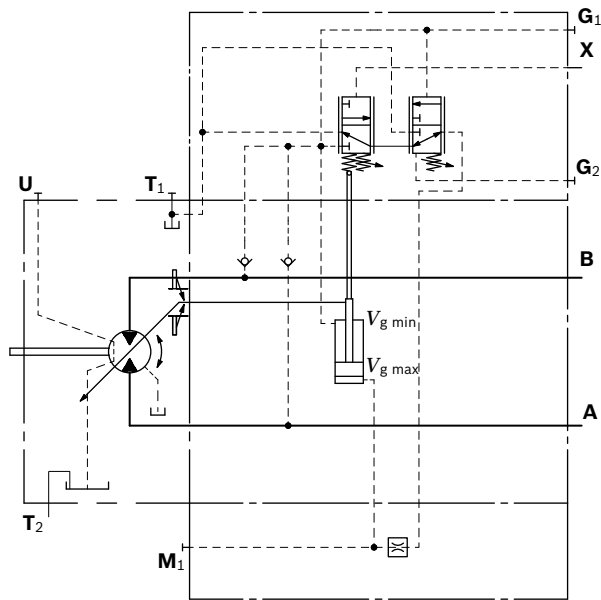

Sizes 250 to 1000 (HD.D)

Pressure control with 2nd pressure setting for HD.D provided as standard (see page 13).

The pressure control setting can be overridden by applying an external pilot pressure at port **G₂**, realizing a 2nd pressure setting.

Necessary pilot pressure at port **G₂**:

$$p_{St} \geq 130 \text{ bar}$$

When ordering, please specify the 2nd pressure setting in plain text.

HD.G pressure control, remote controlled, sizes 250 to 1000

When the pressure command value is reached, the remote controlled pressure control continually regulates the motor to maximum displacement $V_{g \text{ max}}$. A pressure relief valve (not included in the scope of delivery), which is located separately from the motor and which is connected to port **X₃**, assumes the task of controlling the internal pressure cut-off valve. So long as the pressure command value has not been reached, pressure is evenly applied to the valve from both sides in addition to the spring force, and the valve remains closed. The pressure command value is between 80 bar and 350 bar. When the pressure command value is reached at the separate pressure-relief valve, this will open, relieving the pressure on the spring side to the reservoir. The internal control valve switches and the motor swivels to maximum displacement $V_{g \text{ max}}$.

The differential pressure at the DRG control valve is set as standard to 25 bar. As a separate pressure relief valve, we recommend: DBD 6 (hydraulic) as per data sheet 25402; maximum line length should not exceed 2 m.

▼ **Circuit diagram HD.G**

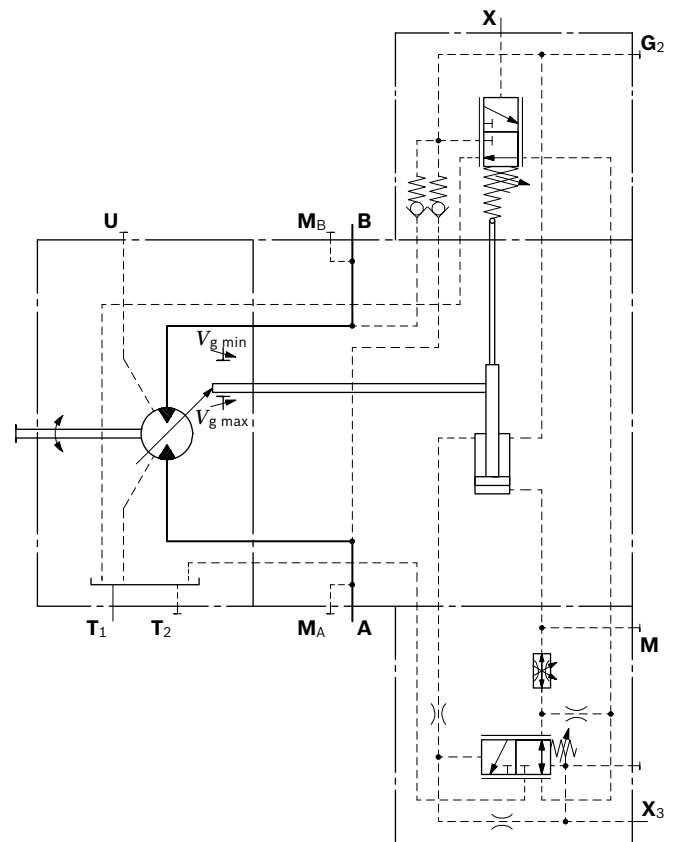

EP – Proportional control, electric

The electric control with proportional solenoid (sizes 28 to 200) or proportional valve (sizes 250 to 1000) enable the displacement to be steplessly adjusted. Control is proportional to the electric control current applied to the solenoid.

Sizes 250 to 1000 require an external pilot oil supply at port **P** with a pressure of $p_{\min} = 30 \text{ bar}$ ($p_{\max} = 100 \text{ bar}$).

- ▶ Beginning of control at $V_{g \max}$ (maximum torque, minimum rotational speed at minimum control current)
- ▶ End of control at $V_{g \min}$ (minimum torque, maximum permissible rotational speed at maximum control current)

▼ Characteristic curve

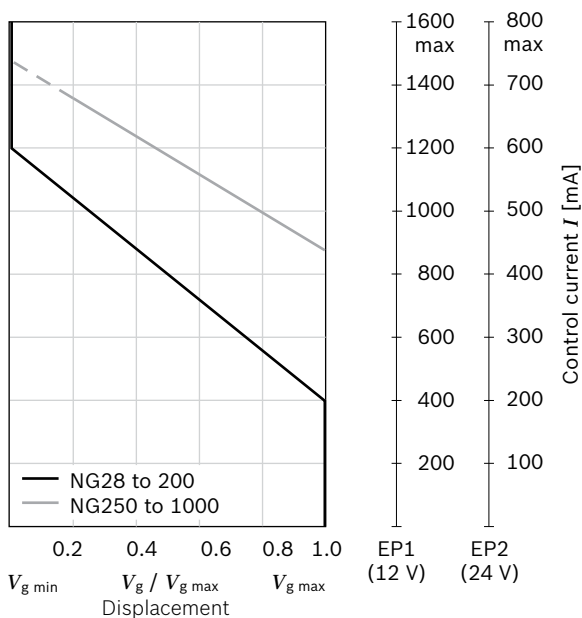

Notice

- ▶ The control oil is internally taken out of the high pressure side of the motor (**A** or **B**). For reliable control, a working pressure of at least 30 bar is necessary in **A** (**B**). If a control operation is performed at a working pressure < 30 bar, an auxiliary pressure of at least 30 bar must be applied at port **G** using an external check valve. For lower pressures at port **G**, please contact us. Please note that at port **G** up to 450 bar (sizes 28 to 200) or 400 bar (sizes 250 to 1000) can occur.
- ▶ The following only needs to be noted for sizes 250 to 1000:
 - The beginning of control and the **EP** characteristic curve are influenced by the case pressure. An increase in the case pressure causes an increase in the beginning of control (see page 6) and thus a parallel displacement of the characteristic curve.

Response time damping

The response time damping impacts the pivot behavior of the motor and consequently the machine response speed.

Standard for sizes 28 to 200

EP1, EP2 without damping.

EP.D, EP.E with throttle pin on both sides, symmetrical (see table)

Option for sizes 28 to 200

EP1, EP2, with throttle pin on both sides, symmetrical (see table)

▼ Throttle pin overview

Size	28	55	80	107	140	160	200
Groove size [mm]	0.3	0.45	0.45	0.55	0.55	0.55	0.65

Standard for sizes 250 to 1000

EP1, EP2 with orifice ($\varnothing 1.2 \text{ mm}$)

EP.D, EP.E, EP.G with adjustable response time limiting valve with orifice ($\varnothing 1.2 \text{ mm}$)

Technical data, solenoid, sizes 28 to 200	EP1	EP2
Voltage	12 V ($\pm 20\%$)	24 V ($\pm 20\%$)
Control current		
Beginning of control	400 mA	200 mA
End of control	1200 mA	600 mA
Current limit	1.54 A	0.77 A
Nominal resistance (at 20 °C)	5.5 Ω	22.7 Ω
Dither		
Frequency	100 Hz	100 Hz
minimum oscillation range ¹⁾	240 mA	120 mA
Duty cycle	100%	100%
Type of protection: see connector version page 72		

Various BODAS controllers with application software and amplifiers are available for controlling the proportional solenoids.

Further information can also be found on the internet at www.boschrexroth.de/mobilelektronik.

Technical data, proportional valve, sizes 250 to 1000	EP1	EP2
Voltage	12 V ($\pm 20\%$)	24 V ($\pm 20\%$)
Control current		
Start of control at $V_{g \max}$	900 mA ¹⁾	450 mA ¹⁾
End of control at $V_{g \min}$	approx. 1360 mA	approx. 680 mA
Current limit	2.2 A	1.0 A
Nominal resistance (at 20 °C)	2.4 Ω	12 Ω
Duty cycle	100%	100%
Type of protection: see connector version page 72		
See also proportional pressure reducing valve DRE 4K (data sheet 29281 – proportional pressure reducing valve)		

1) Setting

▼ **Circuit diagram EP1, EP2, sizes 28 to 200**

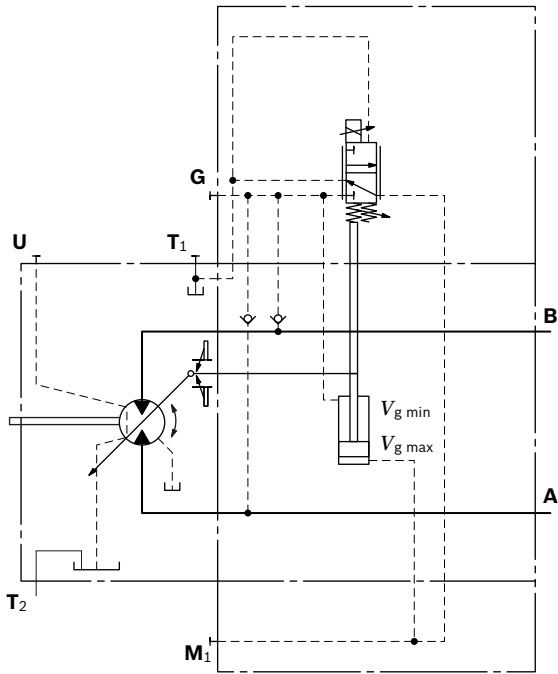

▼ **Circuit diagram EP1, EP2, sizes 250 to 1000**

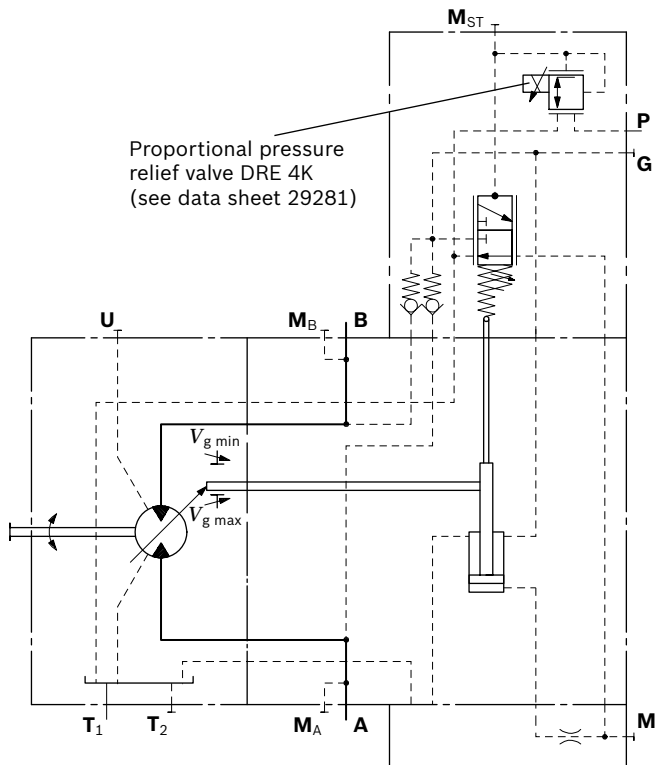

EP.D pressure control, fixed setting

The pressure control overrides the EP control function. If the load torque or a reduction in motor swivel angle causes the system pressure to reach the setpoint value of the pressure control, the motor will swivel towards a larger angle.

The increase in displacement and the resulting reduction in pressure cause the control deviation to decrease. With the increase in displacement the motor develops more torque, while the pressure remains constant.

sizes 28 to 200:

Setting range of the pressure control valve 80 to 400 bar

sizes 250 to 1000:

Setting range of the pressure control valve 80 to 350 bar

▼ **Circuit diagram EP.D, sizes 28 to 200**

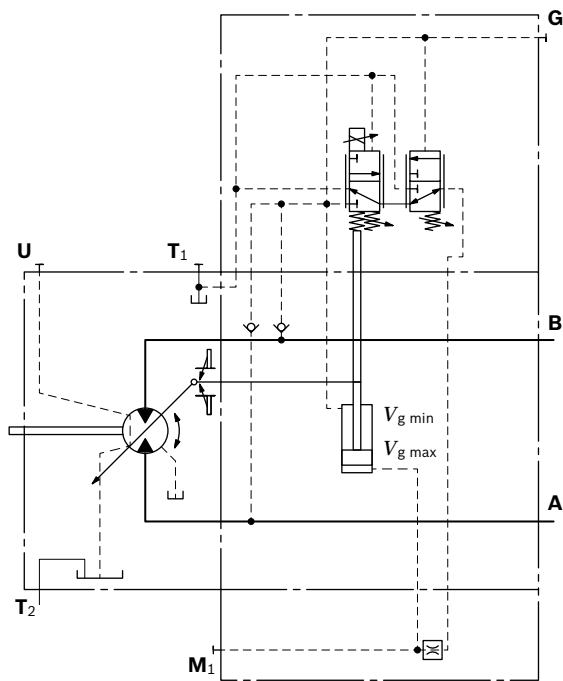

▼ **Circuit diagram EP.D, sizes 250 to 1000**

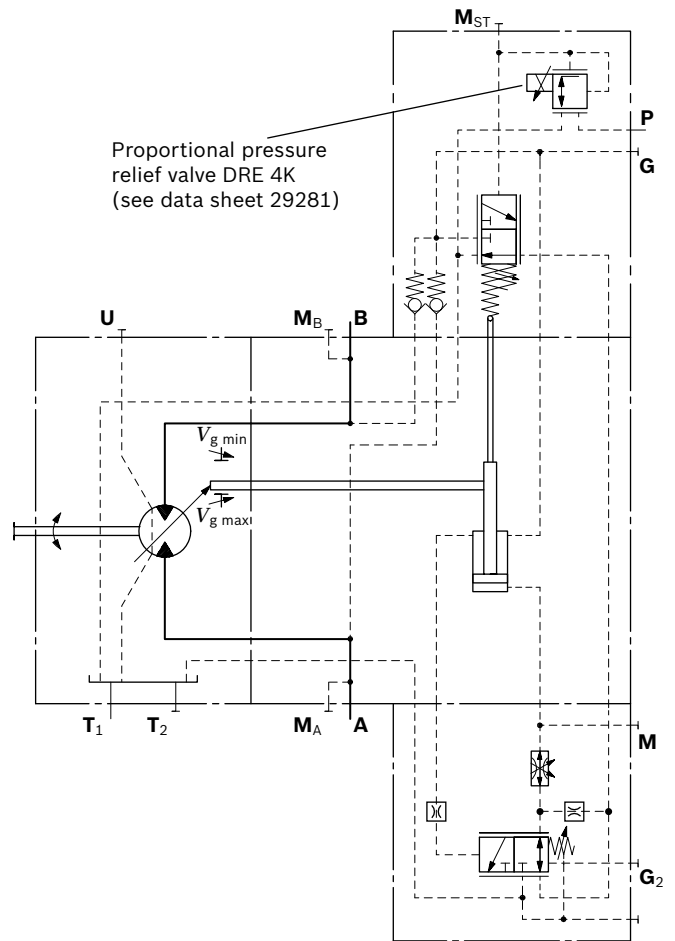

EP.E pressure control, hydraulic override, two-point, sizes 28 to 200

The pressure control setting can be overridden by applying an external pilot pressure at port **G₂**, realizing a 2nd pressure setting realized. Necessary pilot pressure at port **G₂**: $p_{St} = 20$ to 50 bar

When ordering, please specify the 2nd pressure setting in plain text.

▼ **Circuit diagram EP.E**

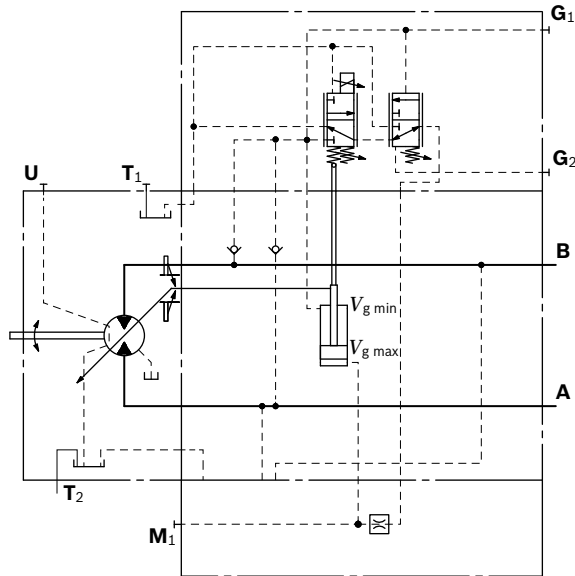

Sizes 250 to 1000 (EP.D)

Pressure control with 2nd pressure setting for EP.D provided as standard (see page 17).

The pressure control setting can be overridden by applying an external pilot pressure at port **G₂**, realizing a 2nd pressure setting.

Necessary pilot pressure at port **G₂**:

$p_{St} \geq 100$ bar

When ordering, please specify the 2nd pressure setting in plain text.

EP.G pressure control, remote controlled, sizes 250 to 1000

When the pressure command value is reached, the remote controlled pressure control continually regulates the motor to maximum displacement $V_{g \max}$. A pressure relief valve (not included in the scope of delivery), which is located separately from the motor and which is connected to port **X₃**, assumes the task of controlling the internal pressure cut-off valve. So long as the pressure command value has not been reached, pressure is evenly applied to the valve from both sides in addition to the spring force, and the valve remains closed. The pressure command value is between 80 bar and 350 bar. When the pressure command value is reached at the separate pressure-relief valve, this will open, relieving the pressure on the spring side to the reservoir. The internal control valve switches and the motor swivels to maximum displacement $V_{g \max}$.

The differential pressure at the DRG control valve is set as standard to 25 bar. As a separate pressure relief valve, we recommend: DBD 6 (hydraulic) as per data sheet 25402; maximum line length should not exceed 2 m.

▼ **Circuit diagram EP.G**

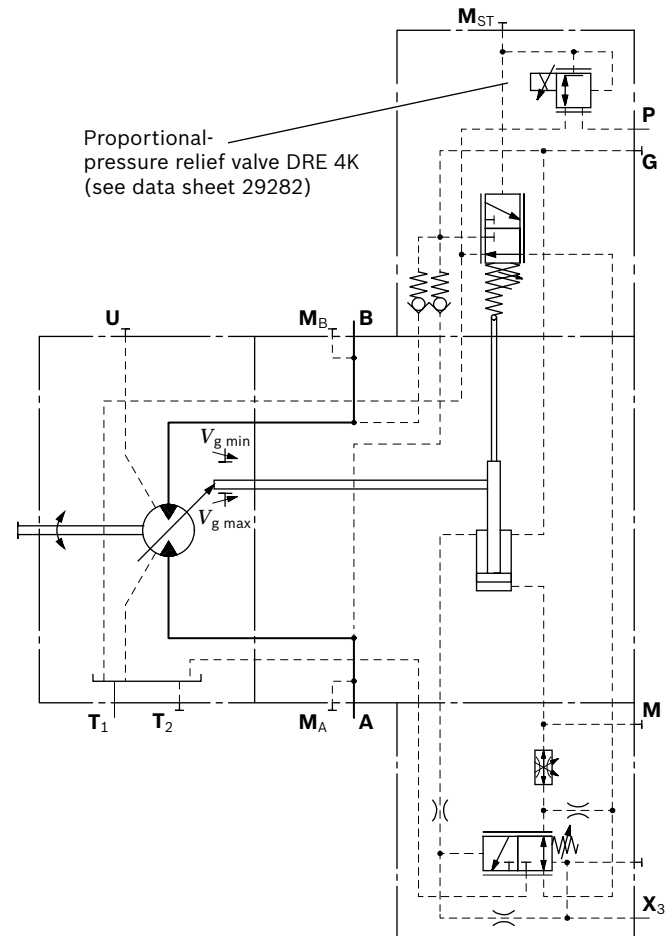

HZ – Two-point control, hydraulic

The two-point hydraulic control allows the displacement to be set to either $V_{g \min}$ or $V_{g \max}$ by switching the pilot pressure at port **X** on or off.

- ▶ Position at $V_{g \max}$ (without pilot pressure, maximum torque, minimum rotational speed)
- ▶ Position at $V_{g \min}$ (with pilot pressure > 15 bar for sizes 28 to 200 and 10 bar for sizes 250 to 1000 switched on, minimum torque, maximum permissible rotational speed)

▼ Characteristic curve

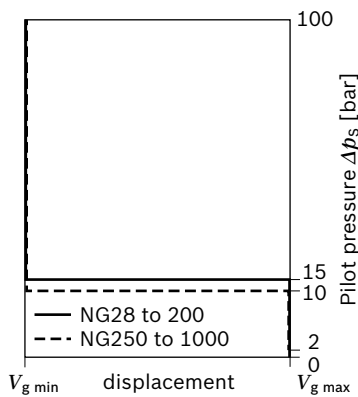

Notice

- ▶ Maximum permissible pilot pressure: 100 bar
- ▶ The control oil is internally taken out of the high pressure side of the motor (**A** or **B**). For reliable control, a working pressure of at least 30 bar is necessary in **A** (**B**). If a control operation is performed at a working pressure < 30 bar, an auxiliary pressure of at least 30 bar must be applied at port **G** using an external check valve. For lower pressures, please contact us. Please note that at port **G** up to 450 bar (sizes 28 to 200) or 400 bar (sizes 250 to 1000) can occur.
- ▶ A leakage flow of maximum 0.3 l/min can occur at port **X** due to internal leakage (working pressure > pilot pressure). The control is to be suitably configured to avoid an independent build-up of pilot pressure.

Response time damping

The response time damping impacts the pivot behavior of the motor and consequently the machine response speed.

Standard for sizes 28, 140 to 200

HZ1 with throttle pin on both sides, symmetrical (see table)

Standard for sizes 55 to 107

HZ3 (synchronous piston) with throttle pin on both sides, symmetrical (see table)

▼ Throttle pin overview

Size	28	55	80	107	140	160	200
Groove size [mm]	0.30	0.30	0.30	0.30	0.55	0.55	0.65

Standard for sizes 250 to 1000 with orifice ($\varnothing 1.2$ mm)

▼ Circuit diagram HZ1, sizes 28, 140, 160, 200

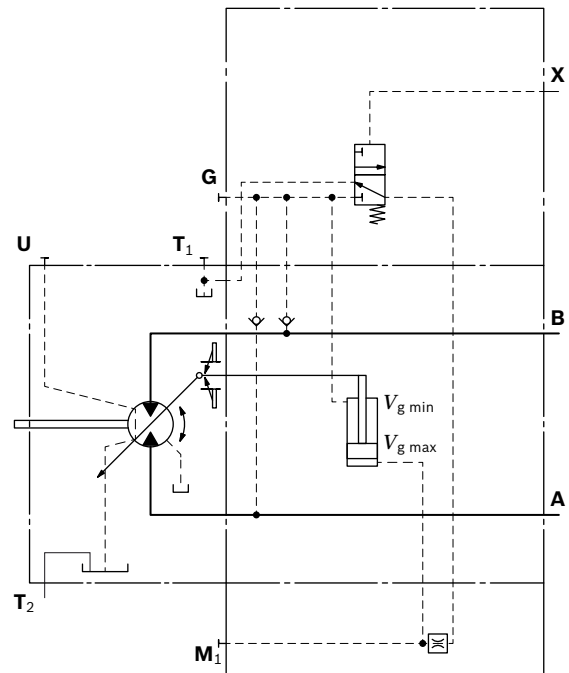

Circuit diagram HZ3, sizes 55 to 107

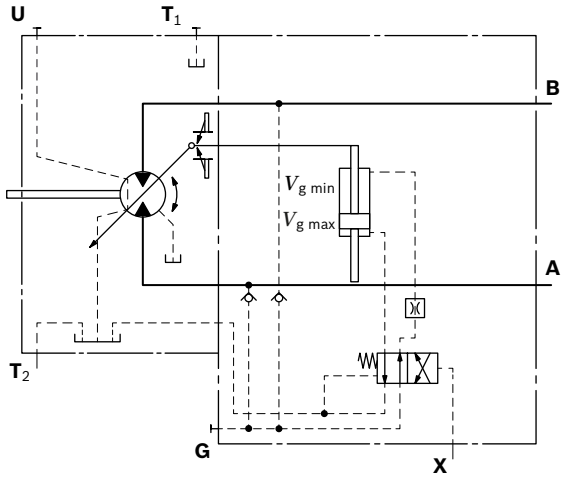

▼ Circuit diagram HZ, sizes 250 to 1000

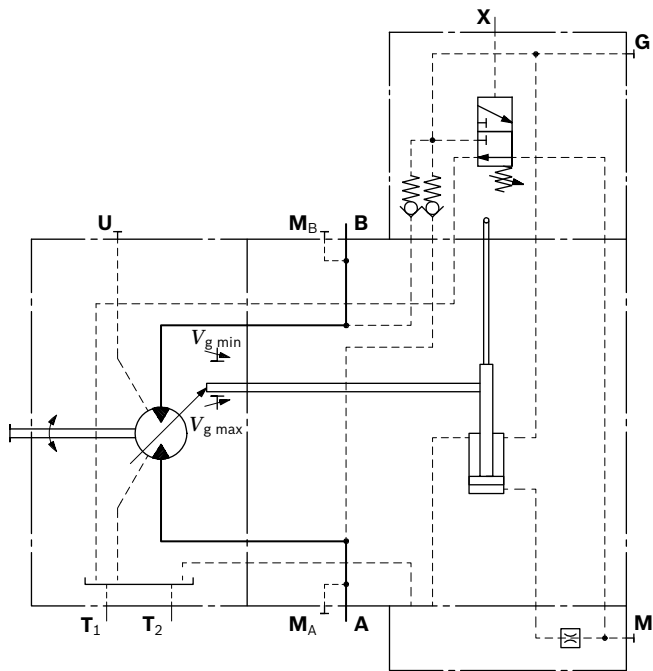

EZ – Two-point control, electric

The two-point electric control allows the displacement to be set to either $V_{g \min}$ or $V_{g \max}$ by switching the electric current on or off to a switching solenoid (sizes 28 to 200) or to an on/off valve (sizes 250 to 1000).

Notice

The control oil is internally taken out of the high pressure side of the motor (**A** or **B**). For reliable control, a working pressure of at least 30 bar is necessary in **A** (**B**). If a control operation is performed at a working pressure < 30 bar, an auxiliary pressure of at least 30 bar must be applied at port **G** using an external check valve. For lower pressures, please contact us.

Please note that at port **G** up to 450 bar (sizes 28 to 200) or 400 bar (sizes 250 to 1000) can occur.

Response time damping

The response time damping impacts the pivot behavior of the motor and consequently the machine response speed.

Standard for sizes 28, 140 to 200

EZ1, EZ2 with throttle pin on both sides, symmetrical (see table)

Standard for sizes 55 to 107

EZ3, EZ4 (synchronous piston) with throttle pin on both sides, symmetrical (see table)

▼ Throttle pin overview

Size	28	55	80	107	140	160	200
Groove size [mm]	0.30	0.30	0.30	0.30	0.55	0.55	0.65

Standard for sizes 250 to 1000 with orifice (ø1.2 mm)

Technical data, solenoid with ø37, sizes 28, 140, 160, 200	EZ1	EZ2
Voltage	12 V (±20%)	24 V (±20%)
Position $V_{g \max}$	de-energized	de-energized
Position $V_{g \min}$	energized	energized
Nominal resistance (at 20 °C)	5.5 Ω	21.7 Ω
Nominal power	26.2 W	26.5 W
Minimum active current required	1.32 A	0.67 A
Duty cycle	100%	100%
Type of protection: see connector version page 72		

▼ Circuit diagram EZ1, EZ2, sizes 28, 140, 160, 200

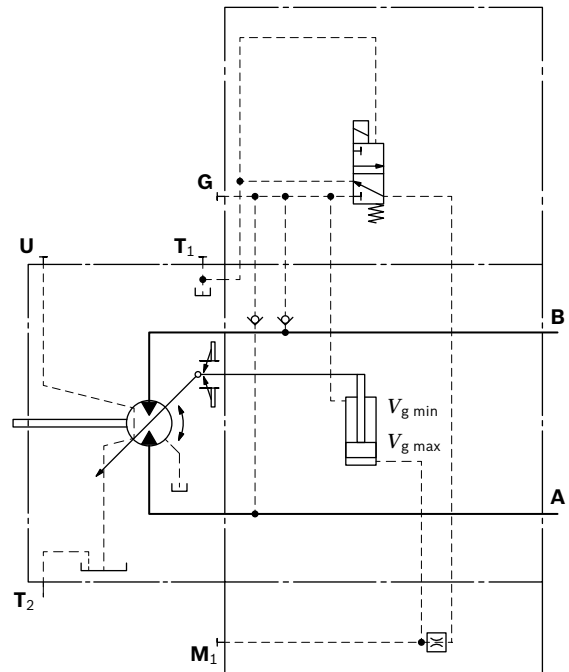

Technical data, solenoid with ø45, sizes 55 to 107	EZ3	EZ4
Voltage	12 V (±20%)	24 V (±20%)
Position $V_{g \max}$	de-energized	de-energized
Position $V_{g \min}$	energized	energized
Nominal resistance (at 20 °C)	4.8 Ω	19.2 Ω
Nominal power	30 W	30 W
Minimum active current required	1.5 A	0.75 A
Duty cycle	100%	100%
Type of protection: see connector version page 72		

▼ Circuit diagram EZ3, EZ4, sizes 55 to 107

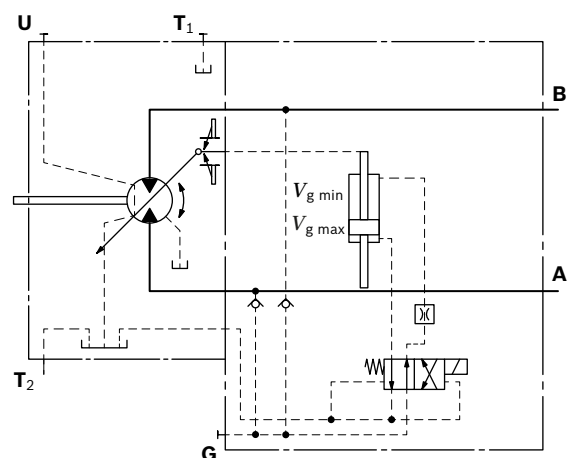

HA – Automatic high-pressure related control

The automatic high-pressure related control adjusts the displacement automatically depending on the working pressure.

The displacement of the A6VM motor with HA control is $V_{g\ min}$ (maximum rotational speed and minimum torque). The control device measures internally the working pressure at **A** or **B** (no control line required) and upon reaching the set beginning of control, the controller swivels the motor with increasing pressure from $V_{g\ min}$ to $V_{g\ max}$. The displacement is modulated between $V_{g\ min}$ and $V_{g\ max}$ depending on the load.

HA1, HA2

- ▶ Beginning of control at $V_{g\ min}$ (minimum torque, maximum rotational speed)
- ▶ End of control at $V_{g\ max}$ (maximum torque, minimum rotational speed)

Notice

- ▶ For safety reasons, winch drives are not permissible with beginning of control at $V_{g\ min}$ (standard for HA).
- ▶ The control oil is internally taken out of the high pressure side of the motor (**A** or **B**). For reliable control, a working pressure of at least 30 bar is necessary in **A** (**B**). If a control operation is performed at a working pressure < 30 bar, an auxiliary pressure of at least 30 bar must be applied at port **G** using an external check valve. For lower pressures, please contact us. Please note that at port **G** up to Please note that at port **G** up to 450 bar (sizes 28 to 200) or 400 bar (sizes 250 to 1000) can occur.
- ▶ The beginning of control and the HA characteristic curve are influenced by the case pressure. An increase in the case pressure causes an increase in the beginning of control (see page 6) and thus a parallel displacement of the characteristic curve. Only for HA1T (sizes 28 to 200) and for HA1, HA2 and HA.T (sizes 250 to 1000).
- ▶ A leakage flow of maximum 0.3 l/min occurs at port **X** (working pressure > pilot pressure). To avoid a build-up of pilot pressure, pressure must to be relieved from port **X** to the reservoir. **Only for HA.T control.**

Response time damping

The response time damping impacts the pivot behavior of the motor and consequently the machine response speed.

Standard for sizes 28 to 200

HA with throttle pin on one side, throttle from $V_{g\ min}$ to $V_{g\ max}$. (see table)

▼ Throttle pin overview

Size	28	55	80	107	140	160	200
Groove size [mm]	0.3	0.45	0.45	0.55	0.55	0.55	0.65

Standard for sizes 55 to 200

HA with BVD or BVE counterbalance valve, with throttle screw (see table)

▼ Throttle screw

Size	55	80	107	140	160	200
Diameter [mm]	0.80	0.80	0.80	0.80	0.80	0.80

Standard for sizes 250 to 1000 with orifice (ø1.2 mm)

HA1 with minimum pressure increase, positive control

A working pressure increase of $\Delta p \leq$ approx. 10 bar results in an increase in displacement from $V_{g \min}$ to $V_{g \max}$.

Sizes 28 to 200:

Setting range of the pressure control valve 80 to 350 bar

Sizes 250 to 1000:

Setting range of the pressure control valve 80 to 340 bar

Please state the desired beginning of control in plain text when ordering, e.g.: beginning of control at 300 bar.

▼ **Characteristic curve HA1**

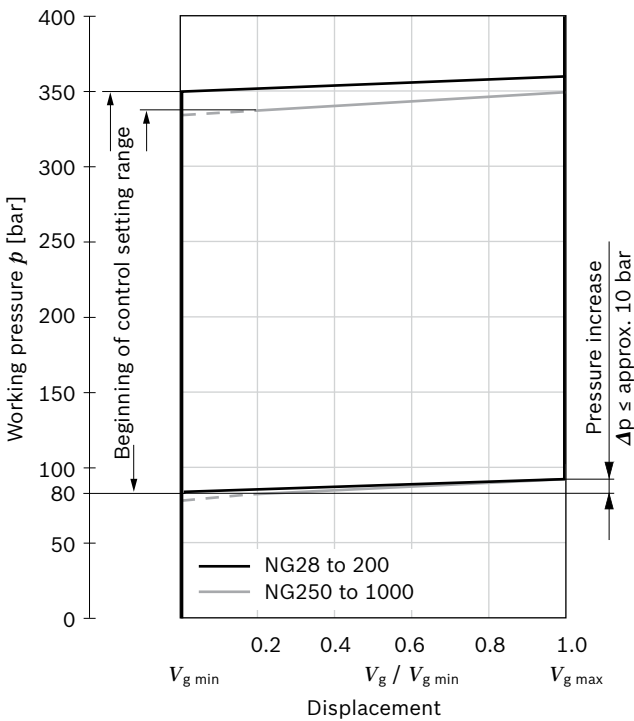

▼ **Circuit diagram HA1, sizes 28 to 200**

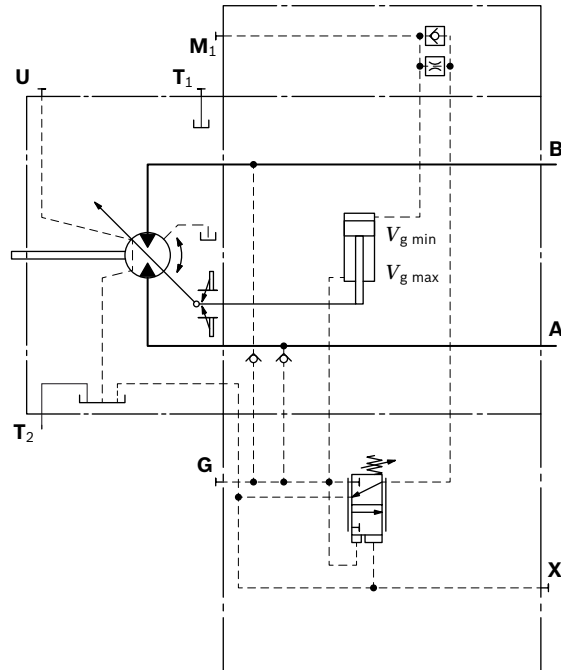

▼ **Circuit diagram HA1, sizes 250 to 1000**

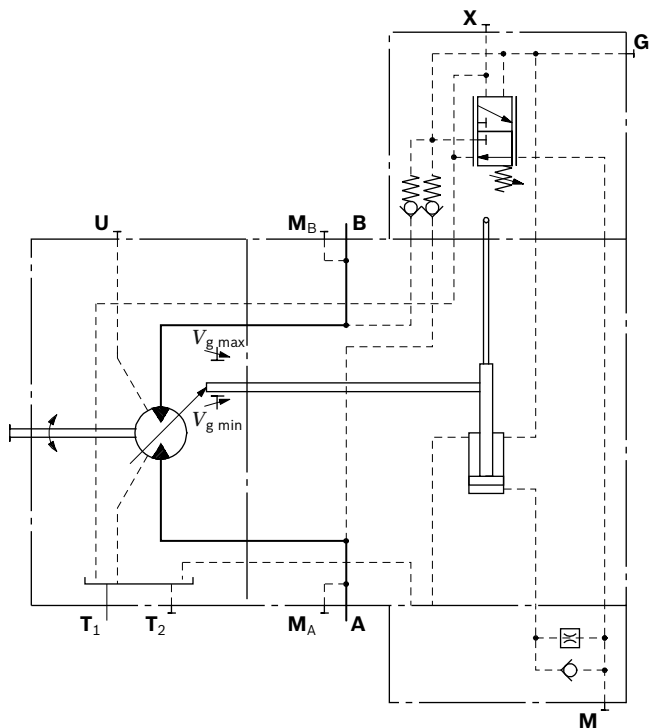

HA2 with pressure increase, positive control

A working pressure increase of $\Delta p \leq$ approx. 100 bar results in an increase in displacement from $V_{g \min}$ to $V_{g \max}$.

Sizes 28 to 200:

Setting range of the pressure control valve 80 to 350 bar

Sizes 250 to 1000:

Setting range of the pressure control valve 80 to 250 bar

Please state the desired beginning of control in plain text when ordering, e.g.: beginning of control at 200 bar.

▼ **Characteristic curve HA2**

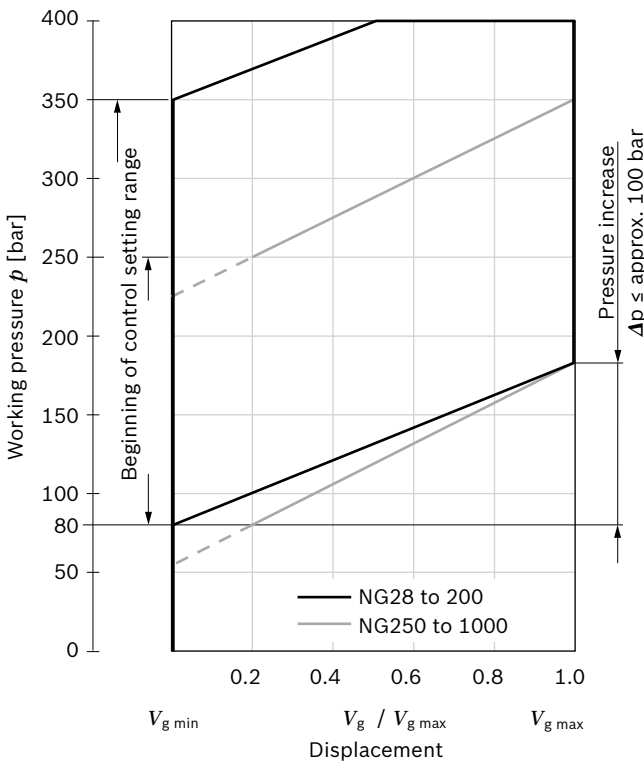

▼ **Circuit diagram HA2, sizes 28 to 200**

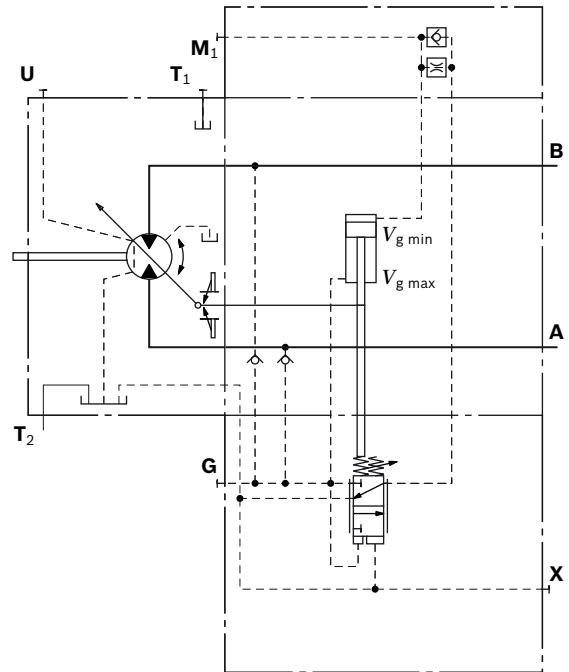

▼ **Circuit diagram HA2, sizes 250 to 1000**

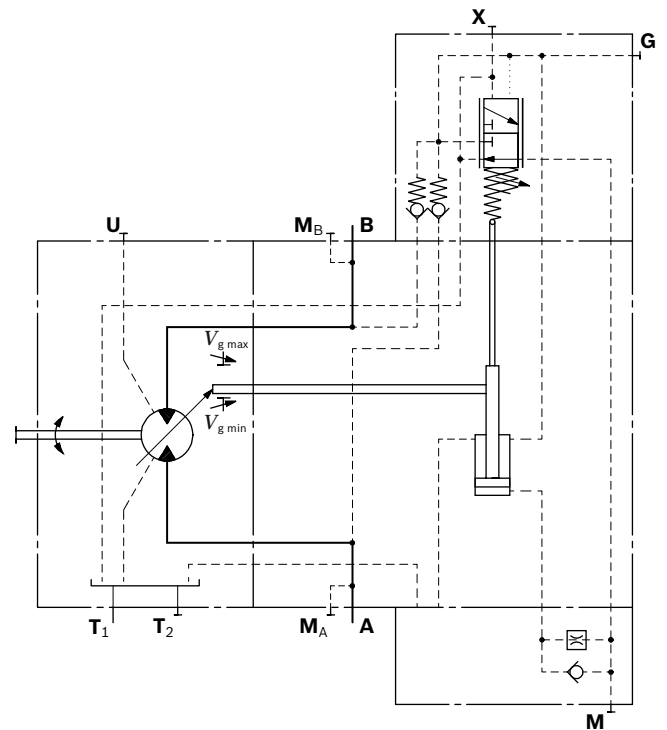

HA.T Hydraulic override, remote control, proportional

With the HA.T3 control, the beginning of control can be influenced by applying a pilot pressure to port **X**.
 For every 1 bar of pilot pressure, the beginning of control is reduced by 17 bar (sizes 28 to 200) or 9 bar (sizes 250 to 1000).

Example (sizes 28 to 200):

Settings for the beginning of control	300 bar	300 bar
Pilot pressure at port X	0 bar	10 bar
Beginning of control at	300 bar	130 bar

Notice

Maximum permissible pilot pressure 100 bar.

▼ **Circuit diagram HA1T, sizes 28 to 200**

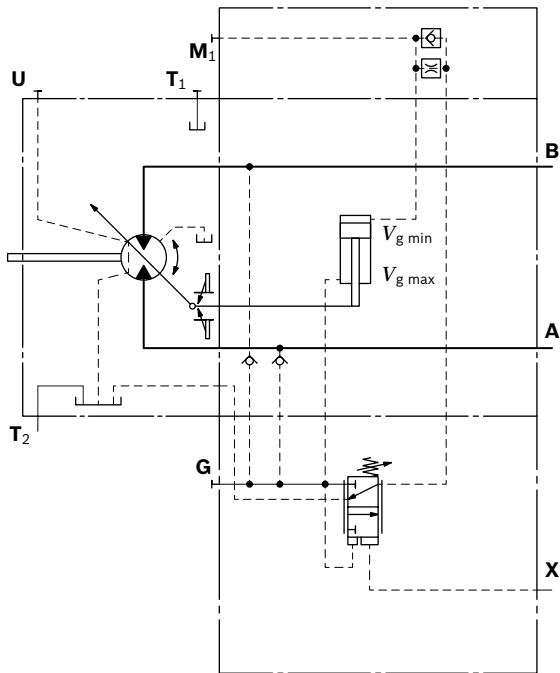

▼ **Circuit diagram HA1T, sizes 250 to 1000**

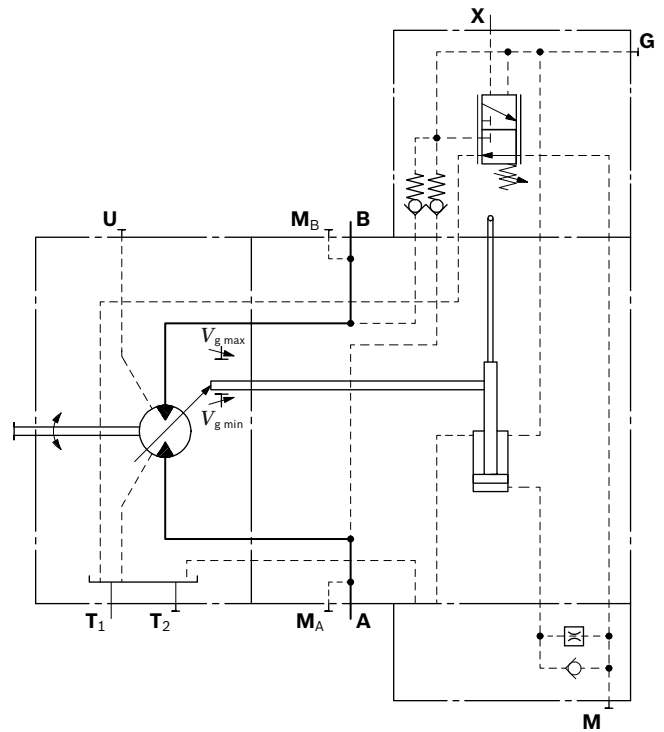

▼ **Circuit diagram HA2T, sizes 28 to 200**

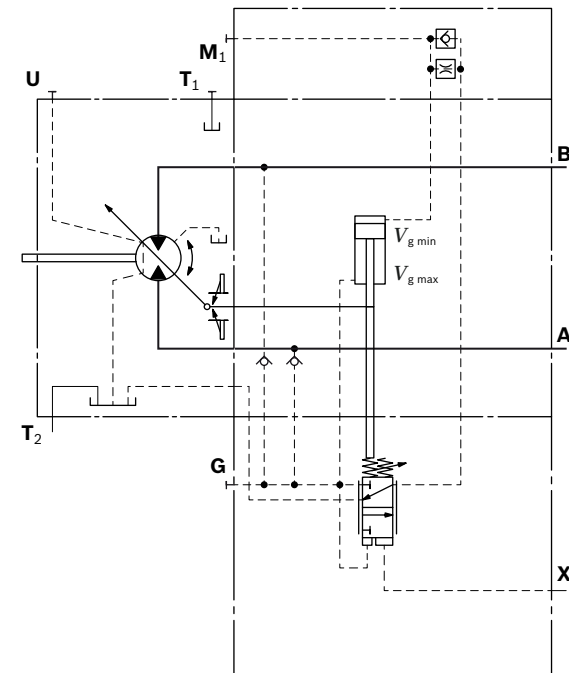

HA.U1, HA.U2 electric override, two-point, sizes 28 to 200

With the HA.U1 or HA.U2 control, the beginning of control can be overridden by an electric signal to a switching solenoid. When the override solenoid is energized, the variable motor swivels to maximum swivel angle, without intermediate position.

The beginning of control can be set between 80 and 300 bar (specify required setting in plain text when ordering).

Technical data, solenoid with Ø45	U1	U2
Voltage	12 V (±20%)	24 V (±20%)
No override	de-energized	de-energized
Position $V_{g \max}$	energized	energized
Nominal resistance (at 20 °C)	4.8 Ω	19.2 Ω
Nominal power	30 W	30 W
Minimum active current required	1.5 A	0.75 A
Duty cycle	100%	100%
Type of protection: see connector version page 72		

▼ **Circuit diagram HA1.U1, HA1.U2**

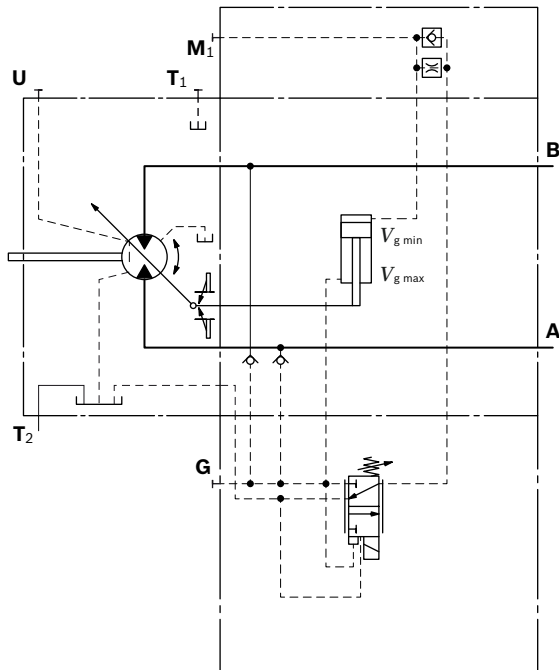

▼ **Circuit diagram HA2.U1, HA2.U2**

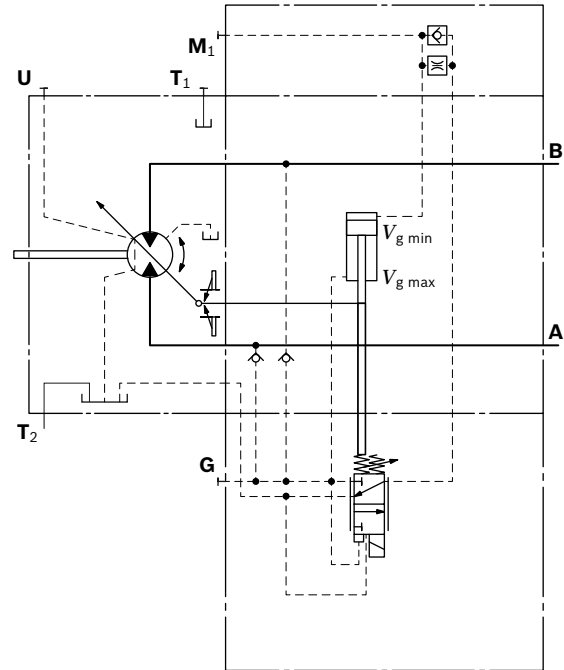

HA.R1, HA.R2 electric override, travel direction valve electric, sizes 28 to 200

With the HA.R1 or HA.R2 control, the beginning of control can be overridden by an electric signal to switching solenoid **b**. When the override solenoid is energized, the variable motor swivels to maximum swivel angle, without intermediate position.

The travel direction valve ensures that the preselected pressure side of the hydraulic motor (**A** or **B**) is always connected to the HA control, and thus determines the swivel angle, even if the high-pressure side changes (e.g. -travel drive during a downhill operation). This thereby prevents undesired swiveling of the variable motor to a larger displacement (jerky deceleration and/or braking characteristics).

Depending on the direction of rotation (direction of travel), the travel direction valve is actuated through the compression spring or the switching solenoid **a** (see page 31).

Electric override

Technical data, solenoid b with $\varnothing 45$	R1	R2
Voltage	12 V ($\pm 20\%$)	24 V ($\pm 20\%$)
No override	de-energized	de-energized
Position $V_{g \max}$	energized	energized
Nominal resistance (at 20 °C)	4.8 Ω	19.2 Ω
Nominal power	30 W	30 W
Minimum active current required	1.5 A	0.75 A
Duty cycle	100%	100%
Type of protection: see connector version page 72		

Travel direction valve, electric

Technical data, solenoid a with $\varnothing 37$	R1	R2
Voltage	12 V ($\pm 20\%$)	24 V ($\pm 20\%$)
Direction of rotation	Working pressure in	
counter-clockwise B	energized	energized
clockwise A	de-energized	de-energized
Nominal resistance (at 20 °C)	5.5 Ω	21.7 Ω
Nominal power	26.2 W	26.5 W
Minimum active current required	1.32 A	0.67 A
Duty cycle	100%	100%
Type of protection: see connector version page 72		

▼ Circuit diagram HA1.R1, HA1.R2

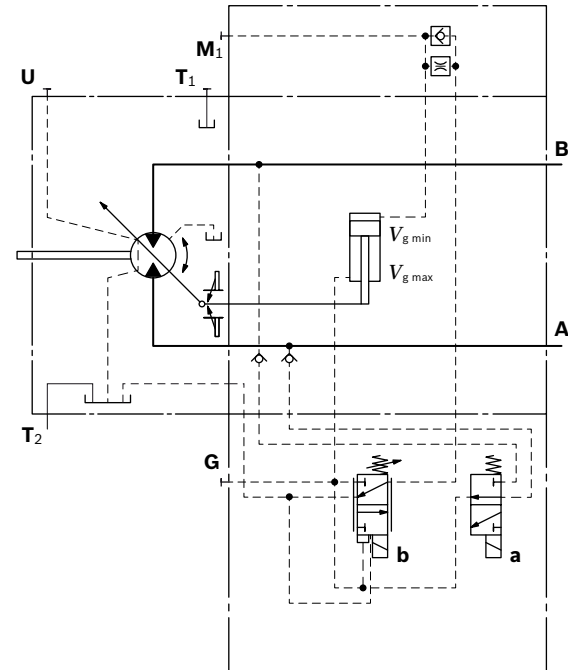

▼ Circuit diagram HA2.R1, HA2.R2

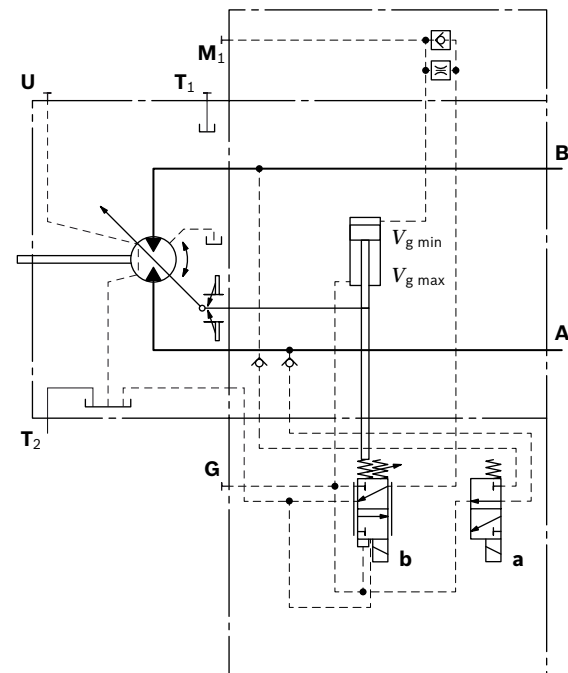

DA – Automatic control, speed related

The variable motor A6VM with automatic speed-related control is intended for use in hydrostatic travel drives in combination with the variable pump A4VG with DA control. A drive speed-related pilot pressure signal is generated by the A4VG variable pump, and that signal, together with the working pressure, regulates the swivel angle of the hydraulic motor.

Increasing drive speed, i.e. increasing pilot pressure, causes the motor to swivel to a smaller displacement (lower torque, higher rotational speed), depending on the working pressure.

If the working pressure exceeds the pressure command value of the controller, the variable motor swivels to a larger displacement (higher torque, lower rotational speed).

- ▶ Pressure ratio $p_{st}/p_{HD} = 3/100, 5/100, 8/100$

DA control is only suitable for certain types of travel drive systems and requires review of the engine and vehicle parameters to ensure that the motor is used correctly and that machine operation is safe and efficient. We recommend that all DA applications be reviewed by a Bosch Rexroth application engineer.

Our Sales department will provide you detailed information.

Notice

The beginning of control and the DA characteristic curve are influenced by case pressure. An increase in the case pressure causes a decrease / reduction in the beginning of control (see page 6) and thus a parallel displacement of the characteristic curve.

Response time damping

The response time damping impacts the pivot behavior of the motor and consequently the machine response speed.

Standard for sizes 28 to 200

DA with throttle pin on one side, throttle from $V_{g \min}$ to $V_{g \max}$. (see table)

▼ Throttle pin overview

Size	28	55	80	107	140	160	200
Groove size [mm]	0.30	0.45	0.45	0.55	0.55	0.55	0.65

Standard for sizes 250 to 1000 with orifice ($\varnothing 1.2$ mm)

DA, DA1, DA4 hydraulic travel direction valve,

Dependent on the direction of rotation (travel direction), the travel direction valve is switched by using pilot pressures X_1 or X_2 . The maximum permissible pilot pressure for sizes 250 to 1000 is $p_{st} = 25$ bar. Momentary ($t < 0.1$ s) pressure peaks of up to 40 bar are permitted.

Direction of rotation	Working pressure in	Pilot pressure in
clockwise	A	X₁
counter-clockwise	B	X₂

▼ Circuit diagram DA1, DA4, sizes 28 to 200

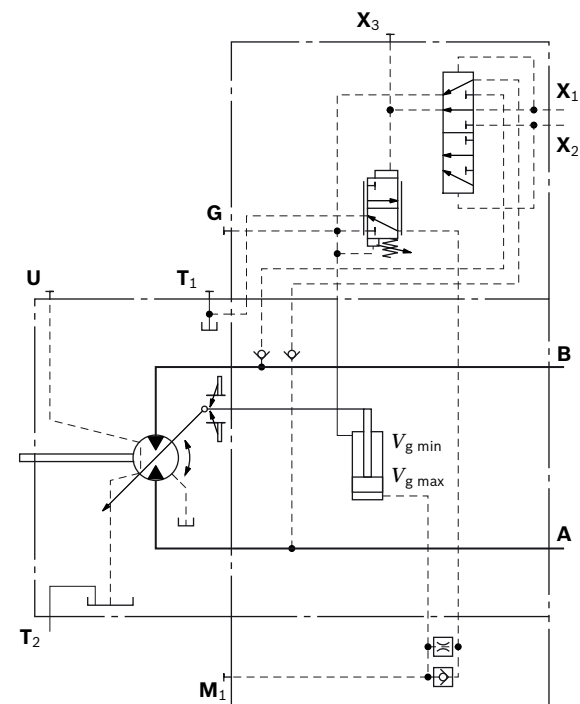

▼ **Circuit diagram DA, sizes 250 to 1000**

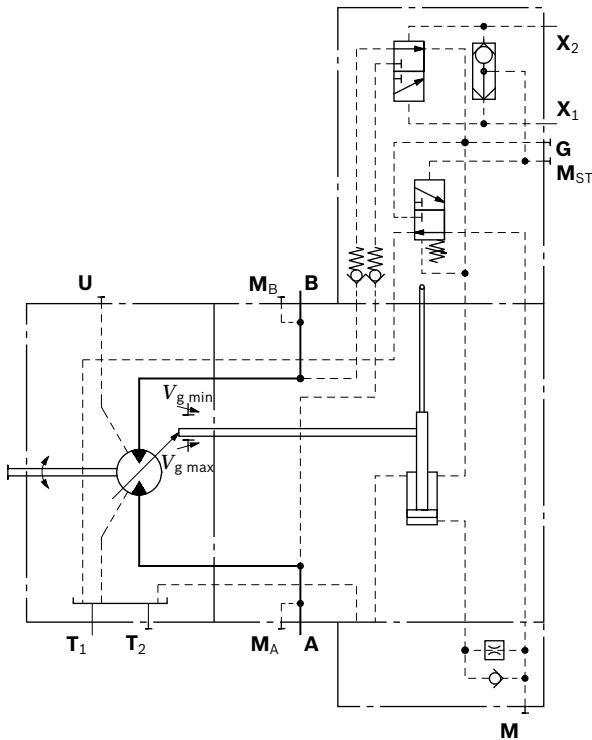

DA2, DA3, DA5, DA6 electric travel direction valve + electric $V_{g \max}$ -circuit, sizes 28 to 200

Depending on the direction of rotation (direction of travel), the travel direction valve is actuated through the compression spring or the switching solenoid **a**.

When switching solenoid **b** is energized, the control can be overridden and the motor can be swiveled to maximum displacement (high torque, lower rotational speed) (electric $V_{g \max}$ -circuit).

Travel direction valve, electric

Technical data, solenoid a with $\varnothing 37$	DA2, DA5	DA3, DA6
Voltage	12 V ($\pm 20\%$)	24 V ($\pm 20\%$)
Direction of rotation	Working pressure in	
counter-clockwise	B	de-energized de-energized
clockwise	A	energized energized
Nominal resistance (at 20 °C)	5.5 Ω	21.7 Ω
Nominal power	26.2 W	26.5 W
Minimum active current required	1.32 A	0.67 A
Duty cycle	100%	100%
Type of protection: see connector version page 72		

Electric override

Technical data, solenoid b with $\varnothing 37$	DA2, DA5	DA3, DA6
Voltage	12 V ($\pm 20\%$)	24 V ($\pm 20\%$)
No override	de-energized	de-energized
Position $V_{g \max}$	energized	energized
Nominal resistance (at 20 °C)	5.5 Ω	21.7 Ω
Nominal power	26.2 W	26.5 W
Minimum active current required	1.32 A	0.67 A
Duty cycle	100%	100%
Type of protection: see connector version page 72		

▼ **Circuit diagram DA2, DA3, DA5, DA6, sizes 28 to 200**

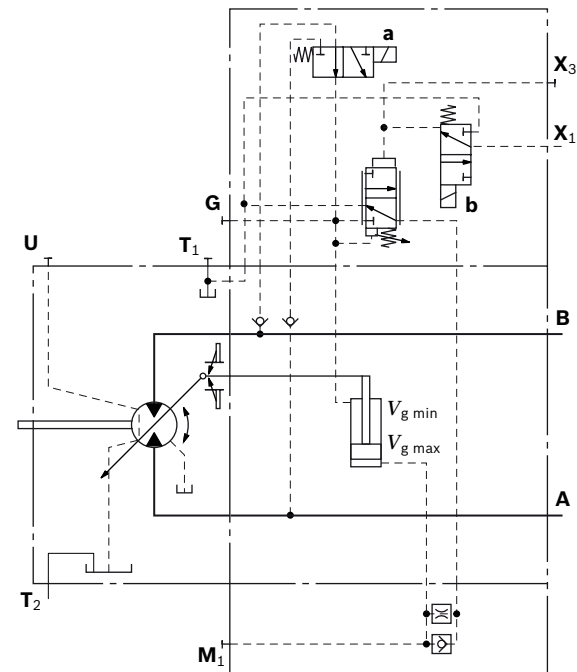

Electric travel direction valve (for DA, HA.R)

Application in travel drives in closed circuits. The travel direction valve of the motor is actuated by an electric signal that also switches the swivel direction of the travel drive pump (e.g. A4VG with DA control valve).

If the pump in the closed circuit is switched to the neutral position or into reverse, the vehicle may experience jerky deceleration or braking, depending on the vehicle weight and current travel speed.

When the travel direction valve, which must be logically coordinated with the pump control, of the pump (e.g. 4/3-way directional valve of the DA-control) is switched to

- ▶ the neutral position,
 - the electrical circuitry causes the previous signal on the travel direction valve on the motor to be retained.
- ▶ Reversing,
 - the electrical circuitry causes the travel direction valve of the motor to switch to the other travel direction following a time delay (approx. 0.8 s) with respect to the pump.

As a result, jerky deceleration or braking is prevented in both cases.

▼ Circuit diagram, electric travel direction valve

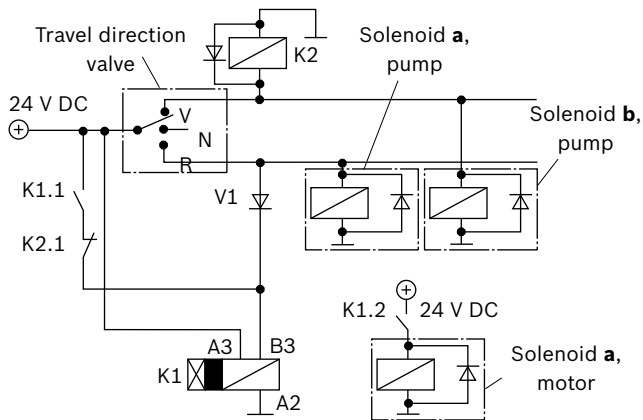

Notice

The shown diodes and relays are not included in the scope of delivery of the motor.

▼ Control, DA2, DA3, DA5, DA6

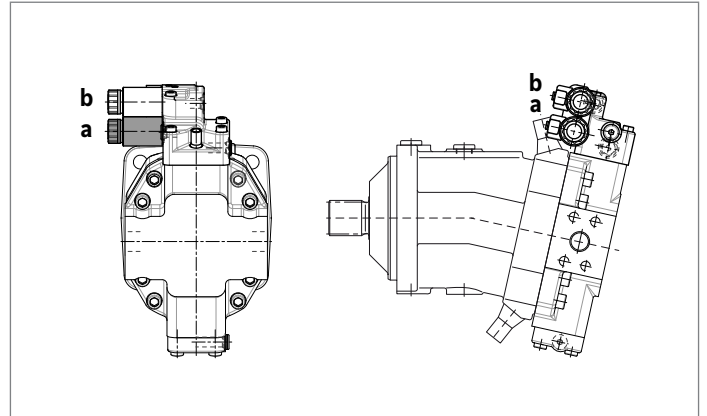

▼ Control, HA1R., HA2R.

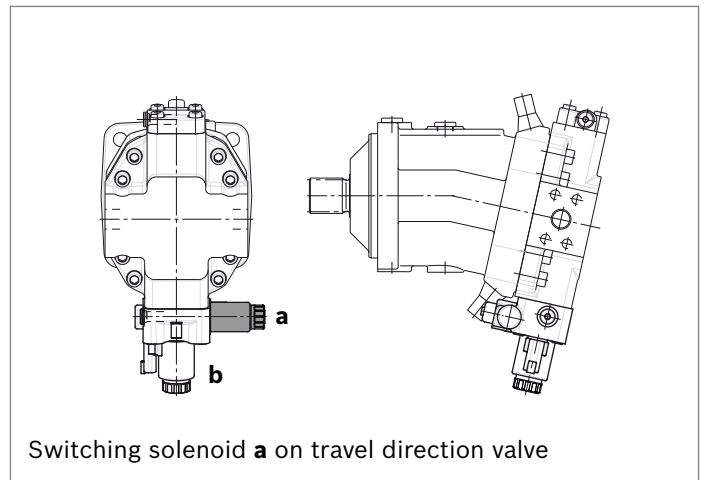

Dimensions, sizes 28

EP1, EP2 – Proportional control, electric

Port plate 2 – SAE working ports **A** and **B** lateral, opposing

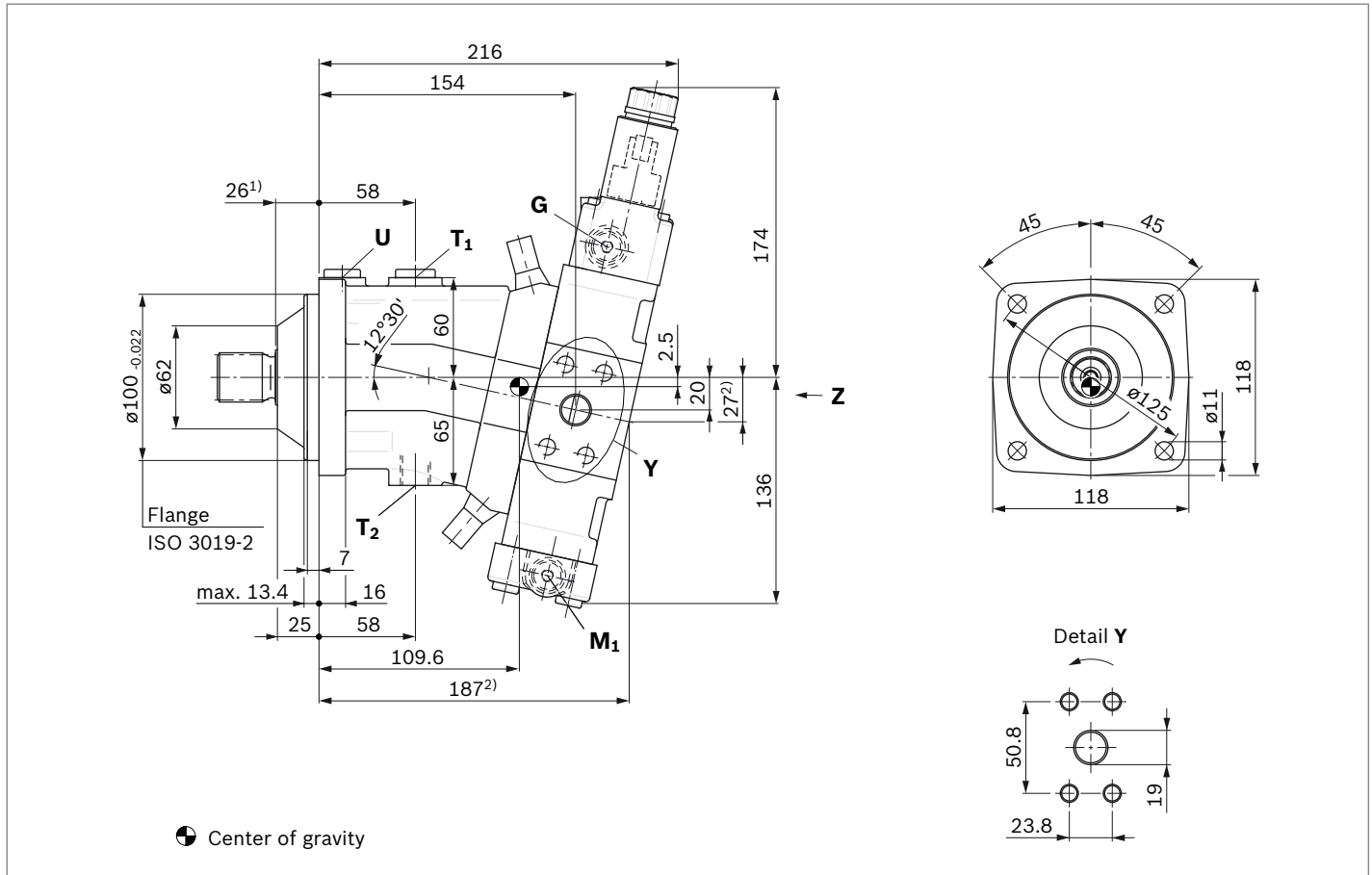

Ports	Standard	Size ³⁾	p_{max} [bar] ⁴⁾	State ⁸⁾
A, B	Working port Fastening thread	SAE J518 ⁵⁾ DIN 13	3/4 in M10 × 1.5; 17 deep	450 O
T₁	Drain port	DIN 3852 ⁷⁾	M18 × 1.5; 12 deep	3 X ⁶⁾
T₂	Drain port	DIN 3852 ⁷⁾	M18 × 1.5; 12 deep	3 O ⁶⁾
G	Synchronous control	DIN 3852 ⁷⁾	M14 × 1.5; 12 deep	450 X
G₂	2nd pressure setting (HD.E, EP.E)	DIN 3852 ⁷⁾	M14 × 1.5; 12 deep	100 X
U	Bearing flushing	DIN 3852 ⁷⁾	M16 × 1.5; 12 deep	3 X
X	Pilot signal (HD, HZ, HA1T/HA2T)	DIN 3852 ⁷⁾	M14 × 1.5; 12 deep	100 O
X	Pilot signal (HA1, HA2)	DIN 3852 ⁷⁾	M14 × 1.5; 12 deep	3 X
X₁, X₂	Pilot signal (DA1, DA4)	DIN 2353-CL	8B-ST	40 O
X₁	Pilot signal (DA2, DA3, DA5, DA6)	DIN 3852 ⁷⁾	M14 × 1.5; 12 deep	40 O
X₃	Pilot signal (DA2, DA3, DA5, DA6)	DIN 3852 ⁷⁾	M14 × 1.5; 12 deep	40 X
M₁	Stroking chamber measurement	DIN 3852 ⁷⁾	M14 × 1.5; 12 deep	450 X

1) To shaft collar

2) Port plate 1 – SAE working ports **A** and **B** at rear

3) For notes on tightening torques, see the instruction manual

4) Depending on the application, momentary pressure peaks can occur. Keep this in mind when selecting measuring devices and fittings.

5) Only dimensions according to SAE J518, metric fastening thread is a deviation from the standard

6) Depending on installation position, **T₁** or **T₂** must be connected (see also installation instructions on page 80).

7) The countersink can be deeper than as specified in the standard.

8) O = Must be connected (plugged when delivered)

X = Plugged (in normal operation)

▼ **Location of the working ports on the port plates (view Z)**

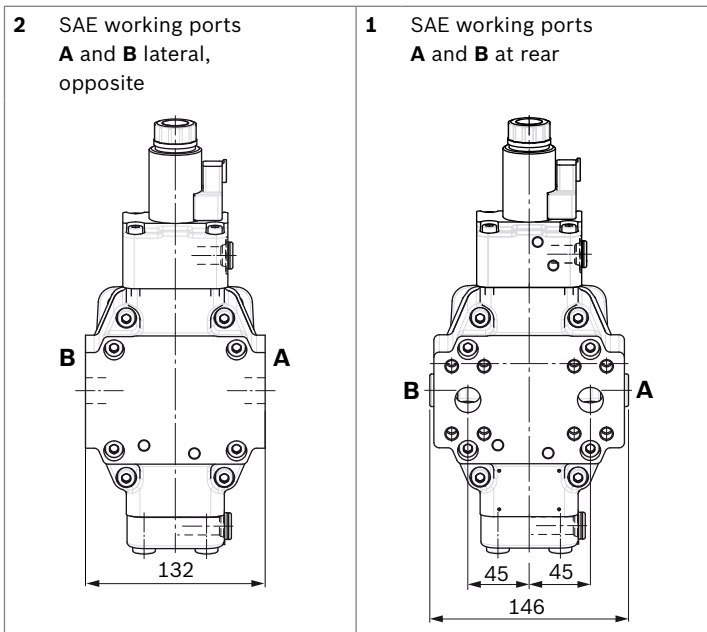

▼ **Splined shaft DIN 5480**

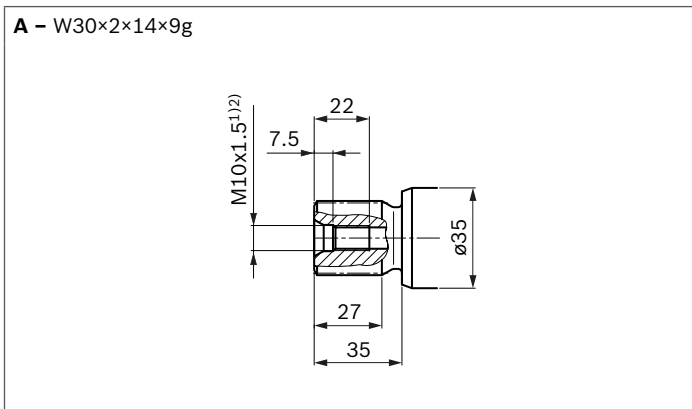

▼ **Splined shaft DIN 5480**

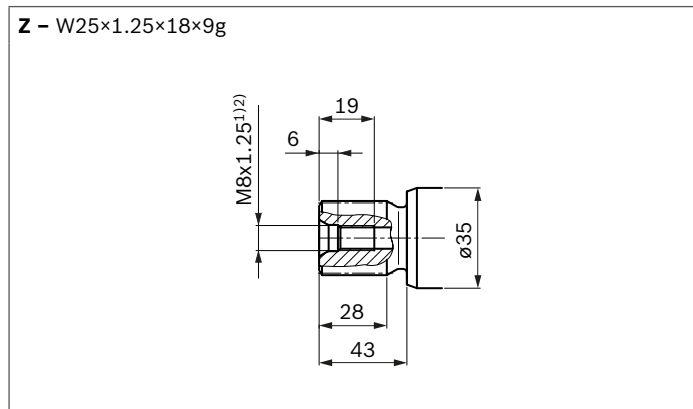

1) For notes on tightening torques, see the instruction manual
 2) Center bore according to DIN 332 (thread according to DIN 13)

▼ **EP.D** – Proportional control, electric,
 with pressure control fixed setting

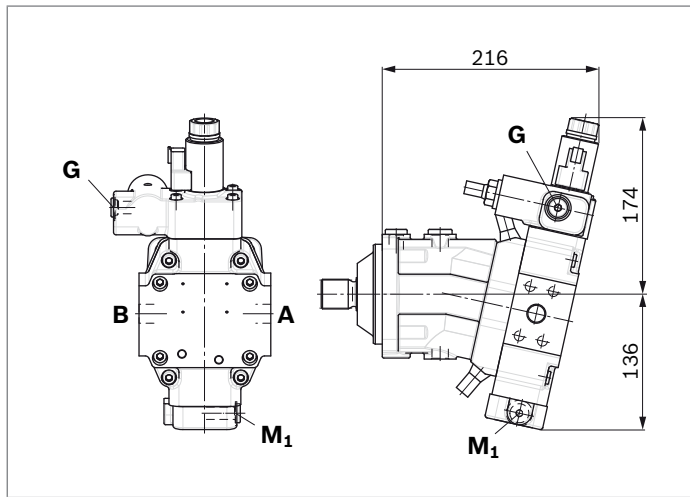

▼ **EP.E** – Proportional control, electric,
 with pressure control hydraulic override, two-point

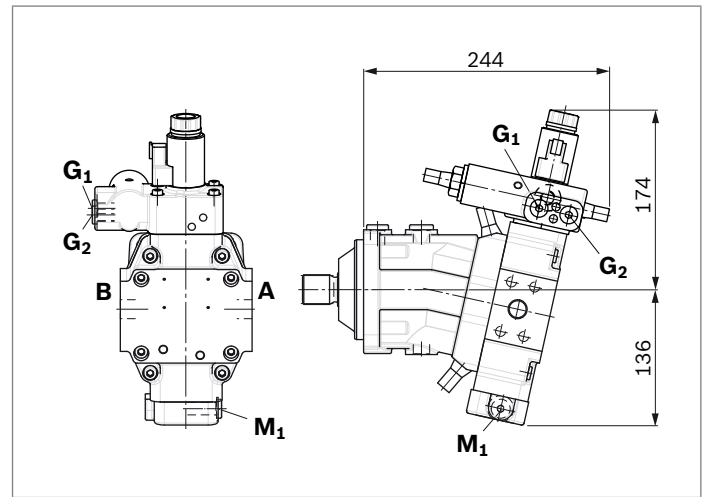

▼ **HD1, HD2** – Proportional control, hydraulic

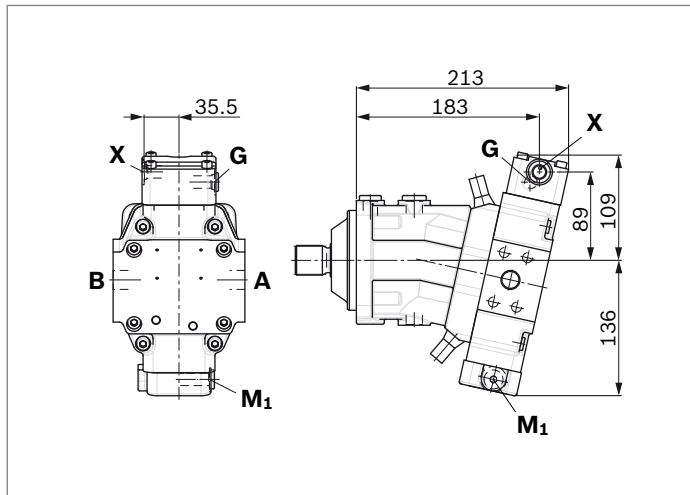

▼ **HD.D** – Proportional control, hydraulic,
 with pressure control fixed setting

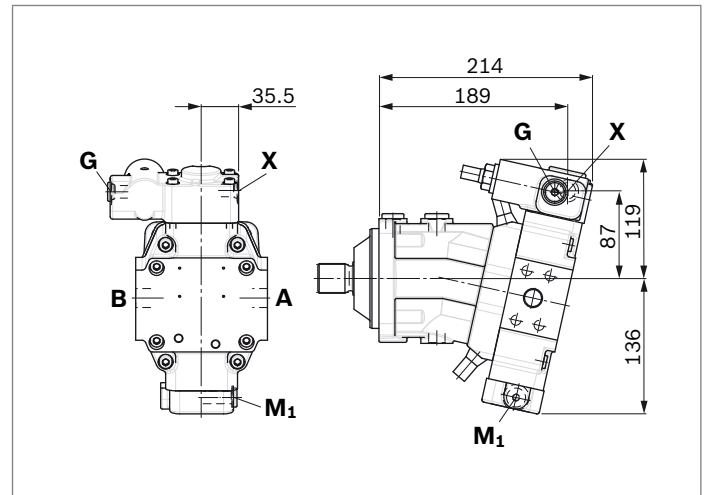

▼ **HD.E** – Proportional control, hydraulic,
 with pressure control hydraulic override, two-point

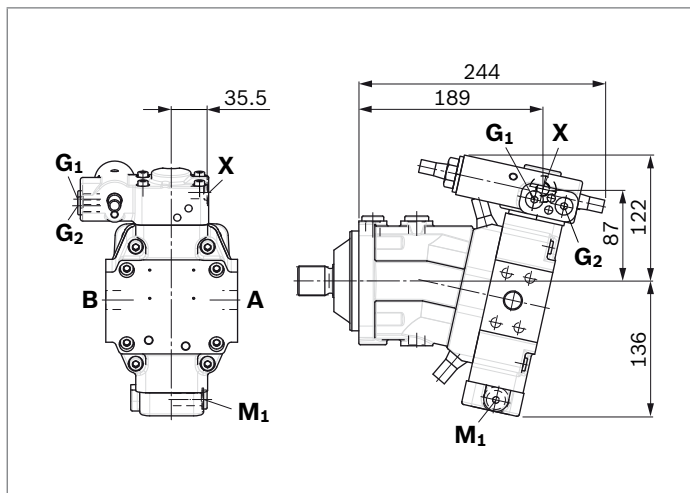

▼ **HZ1** – Two-point control, hydraulic

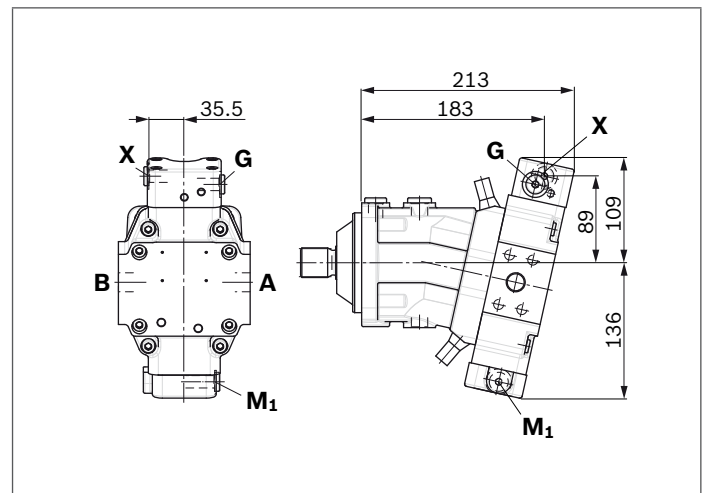

▼ **EZ1, EZ2** – Two-point control, electric

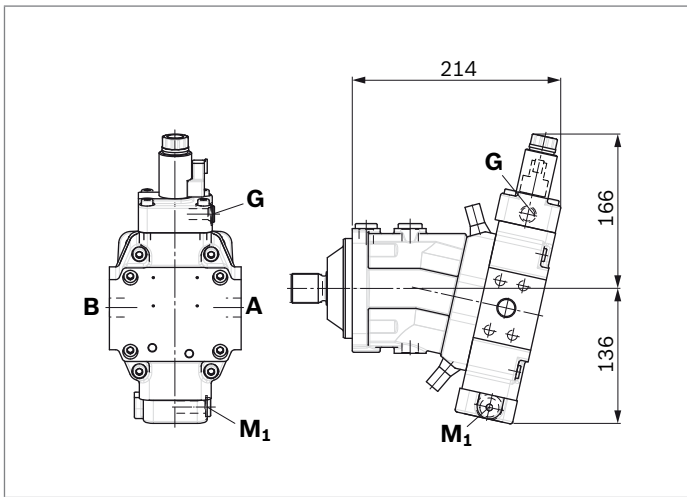

▼ **HA1, HA2 / HA1T, HA2T** – Automatic high-pressure related control, with override, hydraulic remote control, proportional

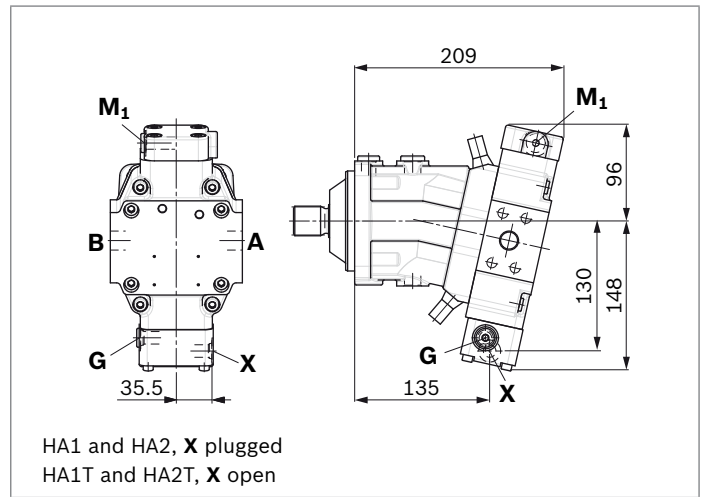

▼ **HA1U1, HA2U2** – Automatic high-pressure related control, with electric override, two-point

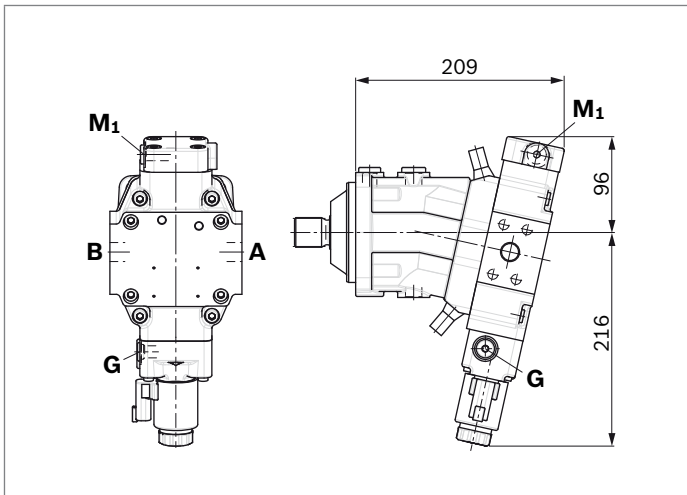

▼ **HA1R1, HA2R2** – Automatic high-pressure related control, with electric override and electric travel direction valve

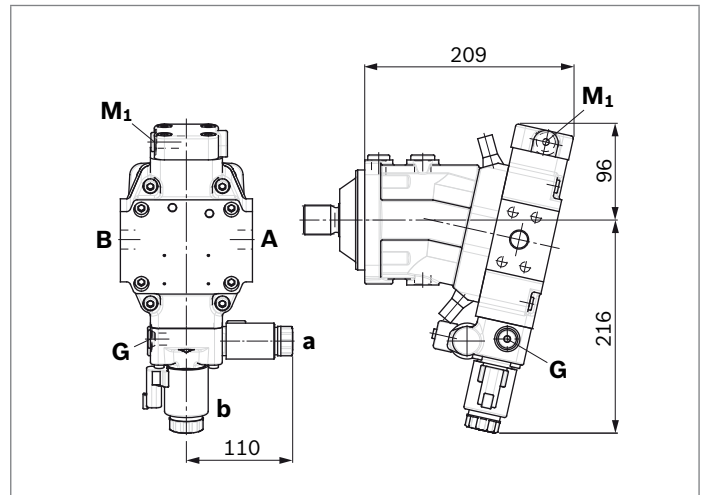

▼ **DA1, DA4** – Automatic speed related control, with hydraulic travel direction valve

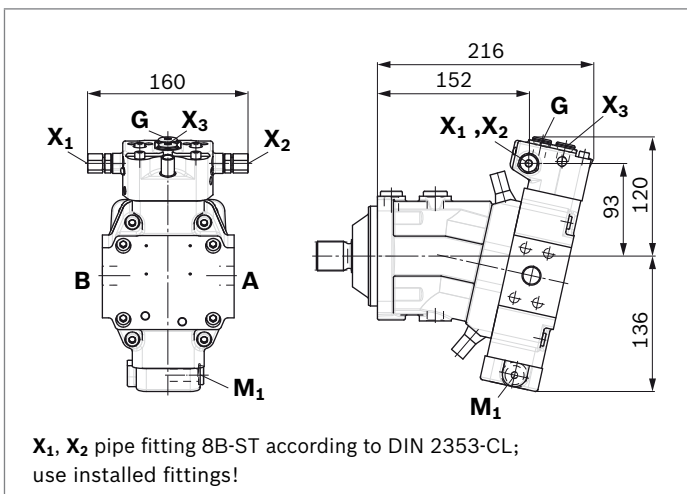

▼ **DA2, DA3, DA5, DA6** – Automatic speed related control, with electric travel direction valve and electric V_{g max}-circuit

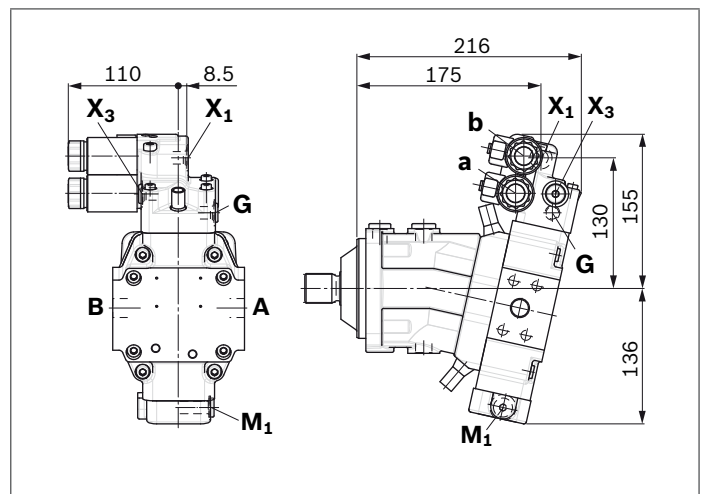

Dimensions, sizes 55

EP1, EP2 – Proportional control, electric

Port plate 2 – SAE working ports **A** and **B** lateral, opposing

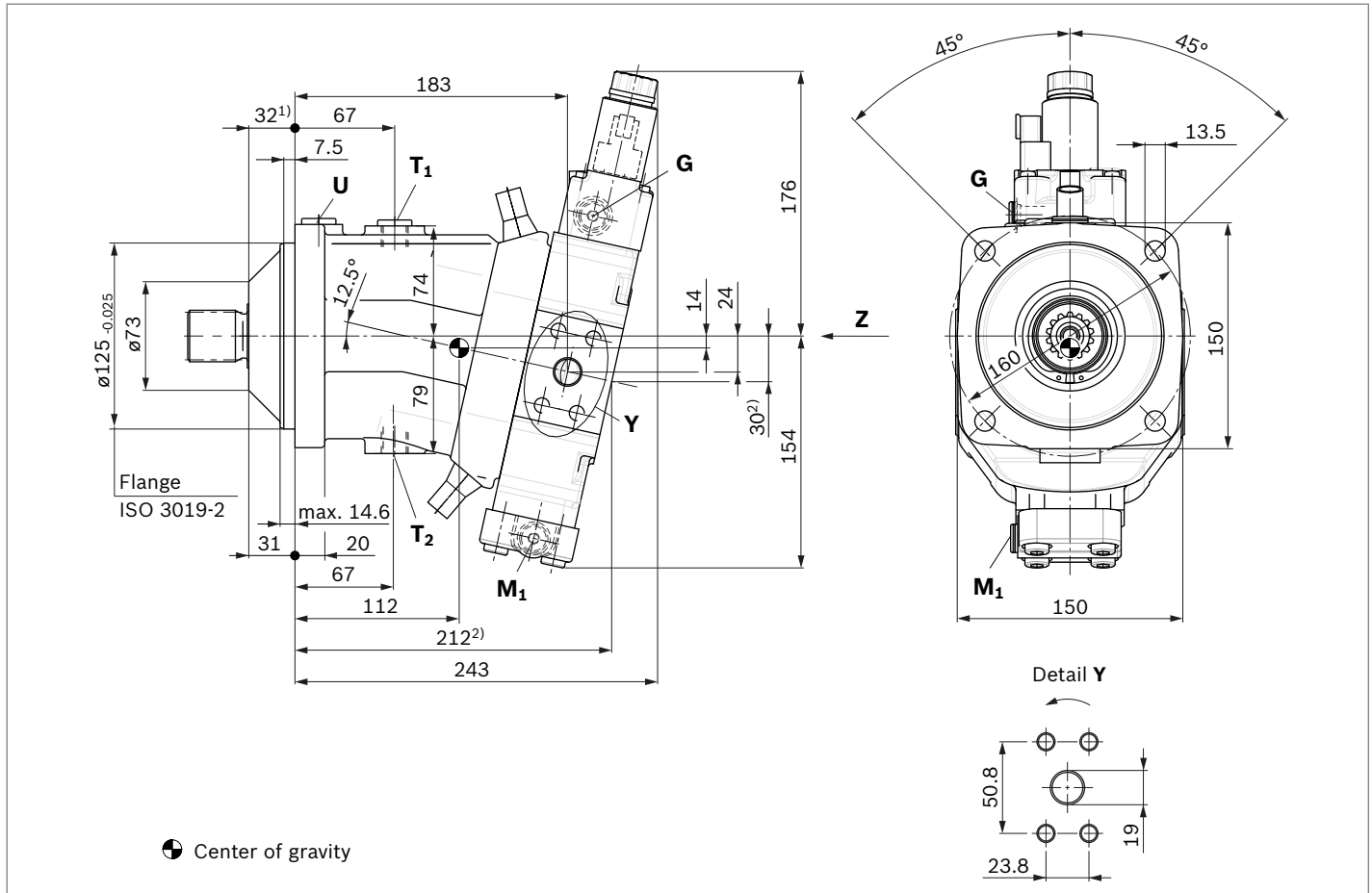

Ports		Standard	Size ³⁾	p_{max} [bar] ⁴⁾	State ⁸⁾
A, B	Working port Fastening thread A/B	SAE J518 ⁵⁾ DIN 13	3/4 in M10 × 1.5; 17 deep	450	O
T₁	Drain port	DIN 3852 ⁶⁾	M18 × 1.5; 12 deep	3	X ⁷⁾
T₂	Drain port	DIN 3852 ⁶⁾	M18 × 1.5; 12 deep	3	O ⁷⁾
G	Synchronous control	DIN 3852 ⁶⁾	M14 × 1.5; 12 deep	450	X
G₂	2nd pressure setting (HD.E, EP.E)	DIN 3852 ⁶⁾	M14 × 1.5; 12 deep	100	X
U	Bearing flushing	DIN 3852 ⁶⁾	M18 × 1.5; 12 deep	3	X
X	Pilot signal (HP, HZ, HA1T/HA2T)	DIN 3852 ⁶⁾	M14 × 1.5; 12 deep	100	O
X	Pilot signal (HA1, HA2)	DIN 3852 ⁶⁾	M14 × 1.5; 12 deep	3	X
X₁, X₂	Pilot signal (DA1, DA4)	DIN 2353-CL	8B-ST	40	O
X₁	Pilot signal (DA2, DA3, DA5, DA6)	DIN 3852 ⁶⁾	M14 × 1.5; 12 deep	40	O
X₃	Pilot signal (DA2, DA3, DA5, DA6)	DIN 3852 ⁶⁾	M14 × 1.5; 12 deep	40	X
M₁	Stroking chamber measurement	DIN 3852 ⁶⁾	M14 × 1.5; 12 deep	450	X

1) To shaft collar
 2) Port plate 1 – SAE working ports **A** and **B** at rear
 3) For notes on tightening torques, see the instruction manual
 4) Depending on the application, momentary pressure peaks can occur. Keep this in mind when selecting measuring devices and fittings.
 5) Only dimensions according to SAE J518, metric fastening thread is a deviation from the standard

6) Depending on installation position, **T₁** or **T₂** must be connected (see also installation instructions on page 80).
 7) The countersink can be deeper than as specified in the standard.
 8) O = Must be connected (plugged when delivered)
 X = Plugged (in normal operation)

▼ **Location of the working ports on the port plates (view Z)**

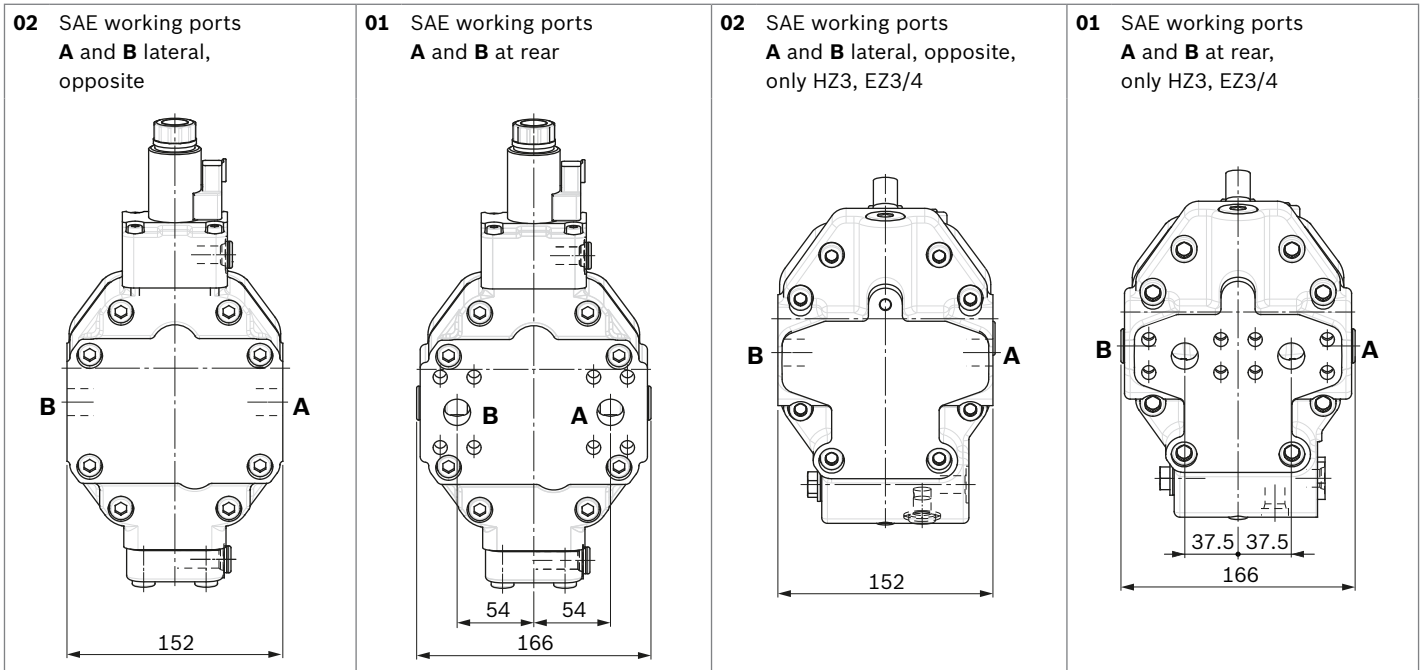

▼ **Splined shaft DIN 5480**

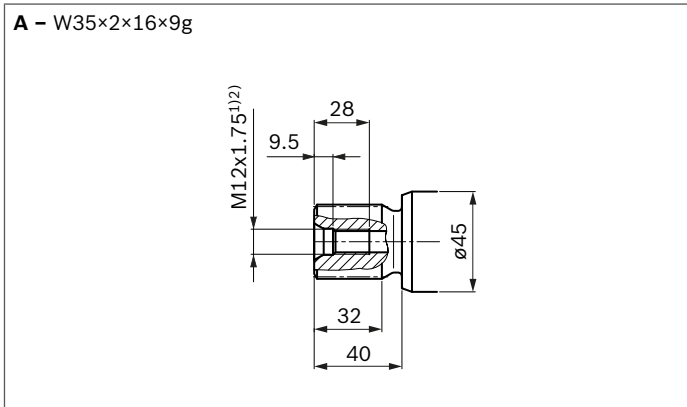

▼ **Splined shaft DIN 5480**

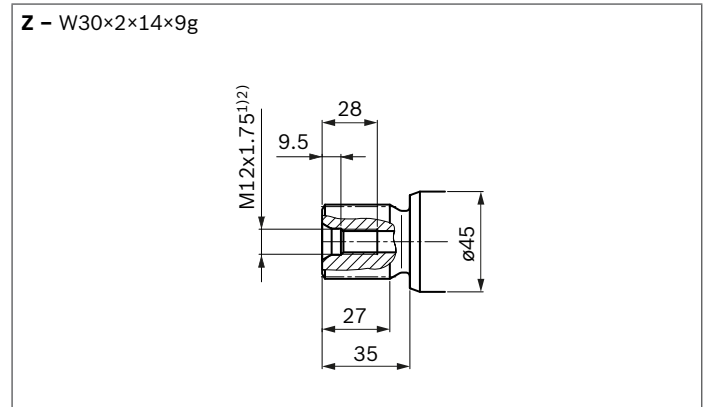

1) For notes on tightening torques, see the instruction manual
 2) Center bore according to DIN 332 (thread according to DIN 13)

▼ **EP.D** – Proportional control, electric,
 with pressure control fixed setting

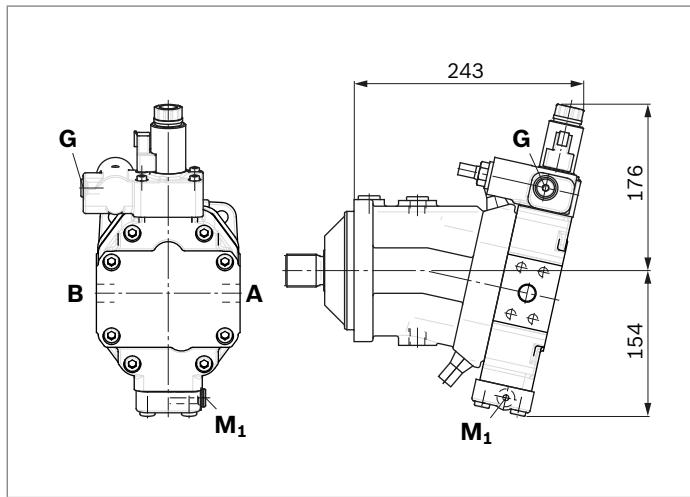

▼ **EP.E** – Proportional control, electric,
 with pressure control hydraulic override, two-point

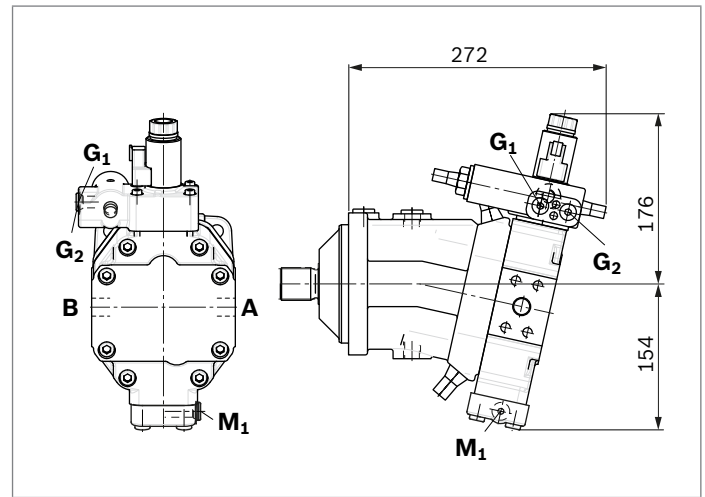

▼ **HD1, HD2** – Proportional control, hydraulic

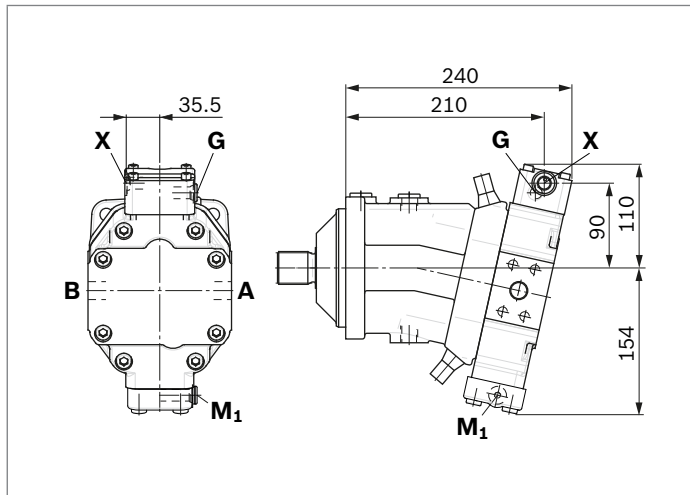

▼ **HD.D** – Proportional control, hydraulic,
 with pressure control fixed setting

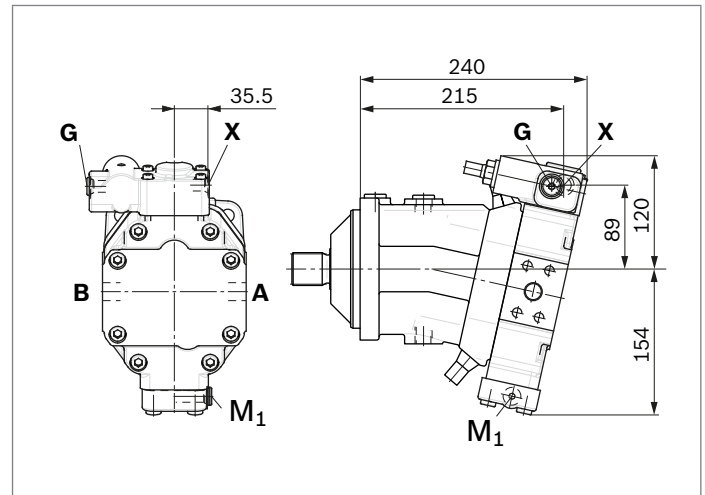

▼ **HD.E** – Proportional control, hydraulic,
 with pressure control hydraulic override, two-point

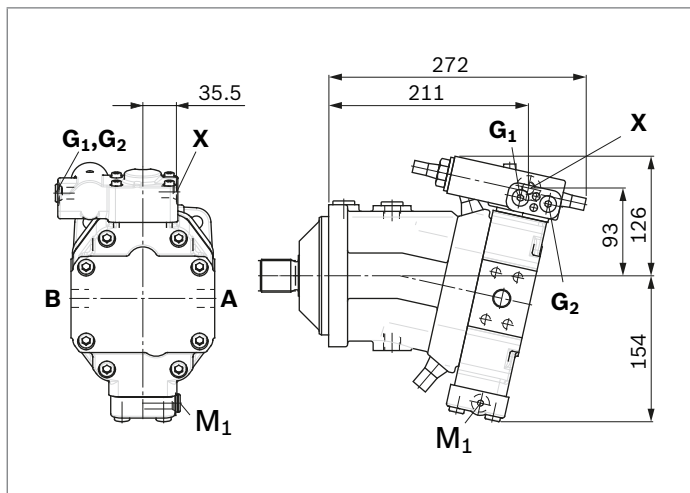

▼ **HZ3** – Two-point control, hydraulic

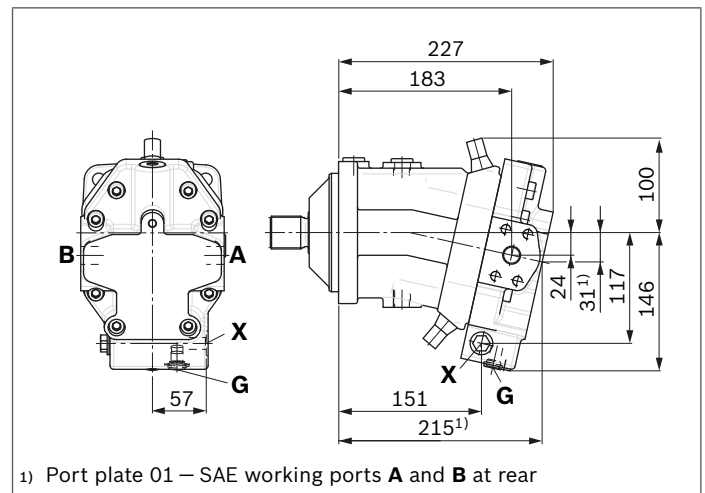

1) Port plate 01 – SAE working ports **A** and **B** at rear

▼ **EZ3, EZ4** – Two-point control, electric

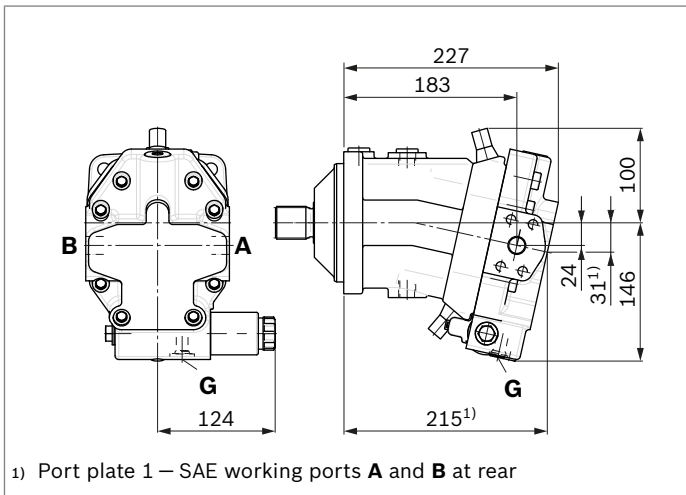

▼ **HA1, HA2 / HA1T, HA2T** – Automatic high-pressure related control, with override, hydraulic remote control, proportional

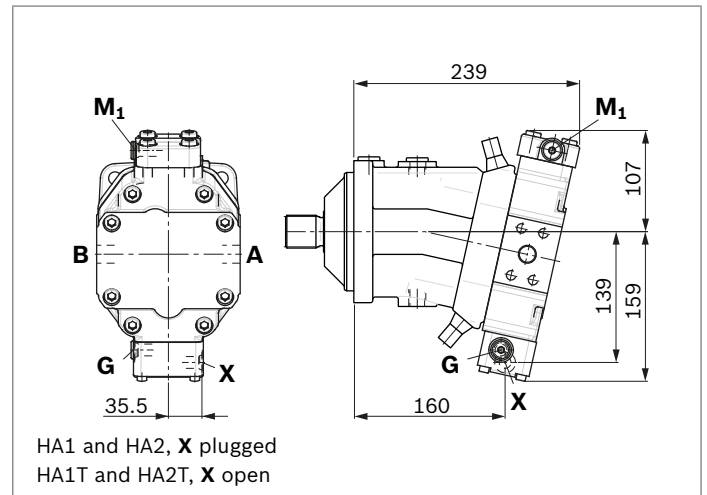

▼ **HA1U1, HA2U2** – Automatic high-pressure related control, with electric override, two-point

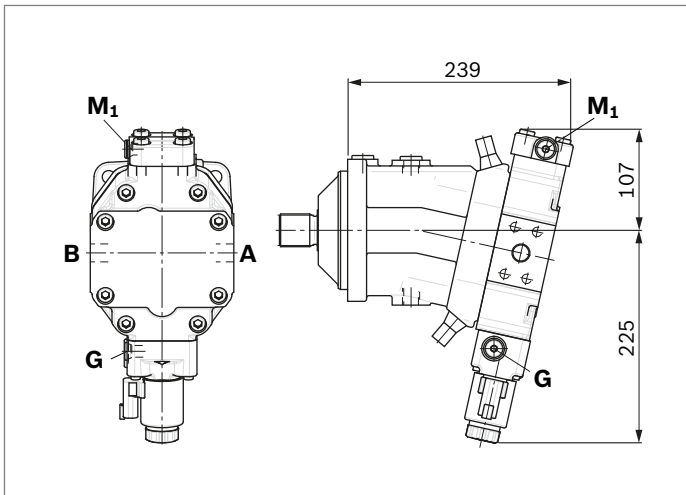

▼ **HA1R1, HA2R2** – Automatic high-pressure related control, with electric override and electric travel direction valve

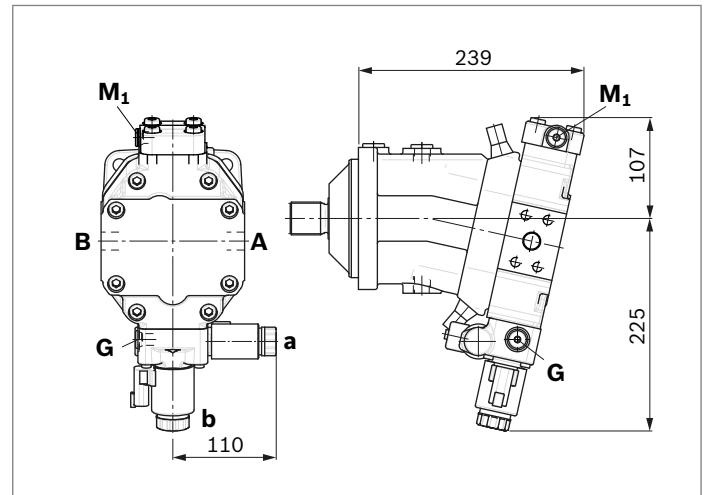

▼ **DA1, DA4** – Automatic speed related control, with hydraulic travel direction valve

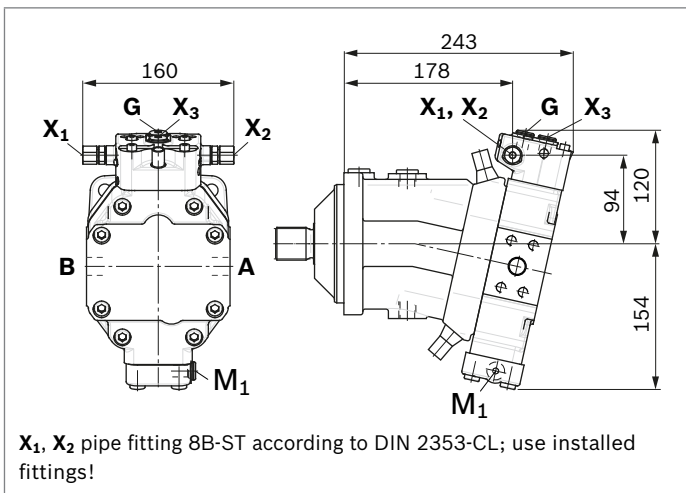

▼ **DA2, DA3, DA5, DA6** – Automatic speed related control, with electric travel direction valve and $V_{g\ max}$ -circuit

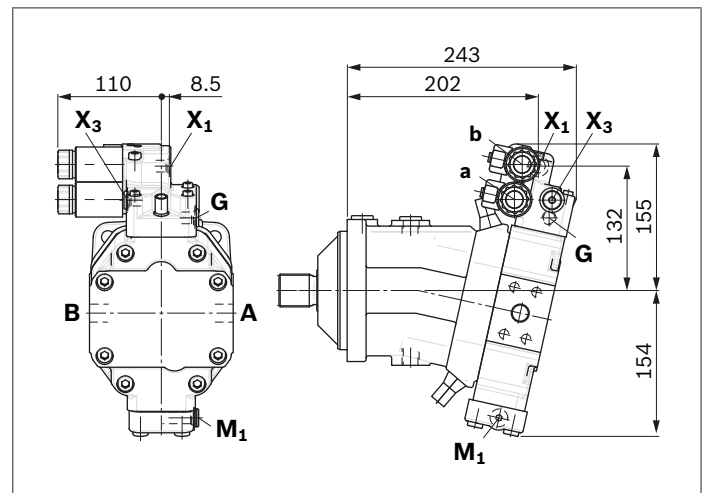

Dimensions, sizes 80

EP1, EP2 – Proportional control, electric

Port plate 2 – SAE working ports **A** and **B** lateral, opposing

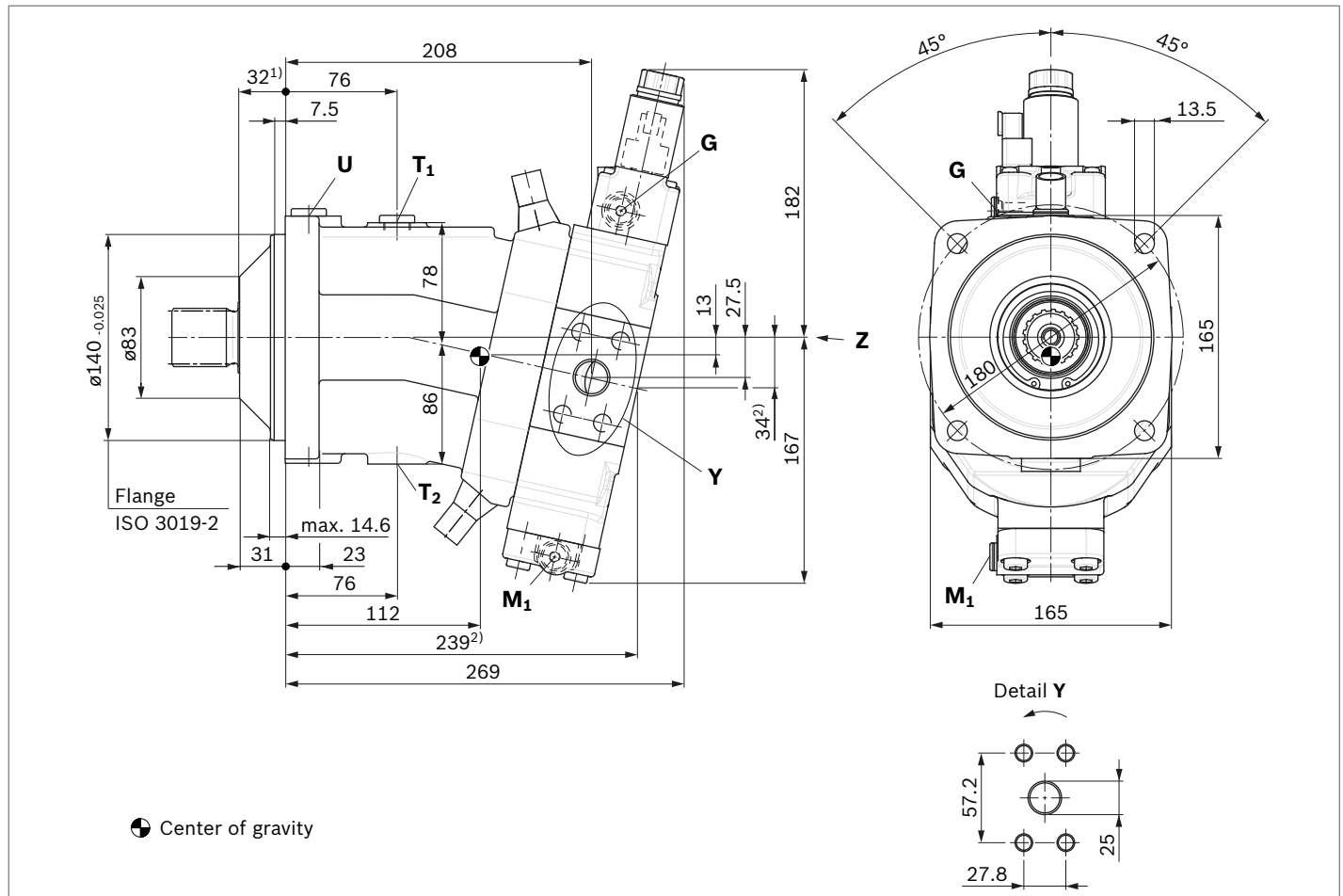

Ports	Standard	Size ³⁾	p_{max} [bar] ⁴⁾	State ⁸⁾
A, B	Working port Fastening thread A/B	SAE J518 ⁵⁾ DIN 13	1 in M12 × 1.75; 17 deep	450 O
T₁	Drain port	DIN 3852 ⁷⁾	M18 × 1.5; 12 deep	3 X ⁶⁾
T₂	Drain port	DIN 3852 ⁷⁾	M18 × 1.5; 12 deep	3 O ⁶⁾
G	Synchronous control	DIN 3852 ⁷⁾	M14 × 1.5; 12 deep	450 X
G₂	2nd pressure setting (HD.E, EP.E)	DIN 3852 ⁷⁾	M14 × 1.5; 12 deep	100 X
U	Bearing flushing	DIN 3852 ⁷⁾	M18 × 1.5; 12 deep	3 X
X	Pilot signal (HP, HZ, HA1T/HA2T)	DIN 3852 ⁷⁾	M14 × 1.5; 12 deep	100 O
X	Pilot signal (HA1, HA2)	DIN 3852 ⁷⁾	M14 × 1.5; 12 deep	3 X
X₁, X₂	Pilot signal (DA1, DA4)	DIN 2353-CL	8B-ST	40 O
X₁	Pilot signal (DA2, DA3, DA5, DA6)	DIN 3852 ⁷⁾	M14 × 1.5; 12 deep	40 O
X₃	Pilot signal (DA2, DA3, DA5, DA6)	DIN 3852 ⁷⁾	M14 × 1.5; 12 deep	40 X
M₁	Stroking chamber measurement	DIN 3852 ⁷⁾	M14 × 1.5; 12 deep	450 X

1) To shaft collar

2) Port plate 1 – SAE working ports **A** and **B** at rear

3) For notes on tightening torques, see the instruction manual

4) Depending on the application, momentary pressure peaks can occur. Keep this in mind when selecting measuring devices and fittings.

5) Only dimensions according to SAE J518, metric fastening thread is a deviation from the standard

6) Depending on installation position, **T₁** or **T₂** must be connected (see also installation instructions on page 80).

7) The countersink can be deeper than as specified in the standard.

8) O = Must be connected (plugged when delivered)

X = Plugged (in normal operation)

▼ **Location of the working ports on the port plates (view Z)**

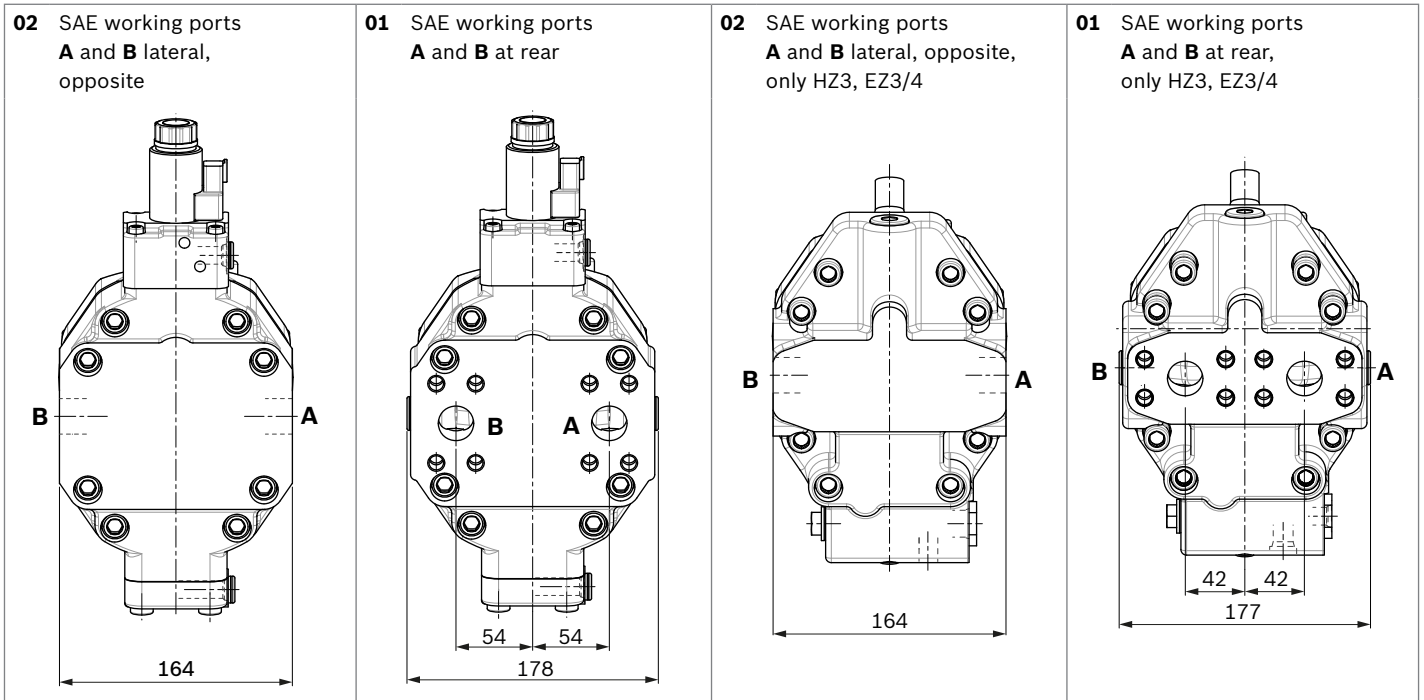

▼ **Splined shaft DIN 5480**

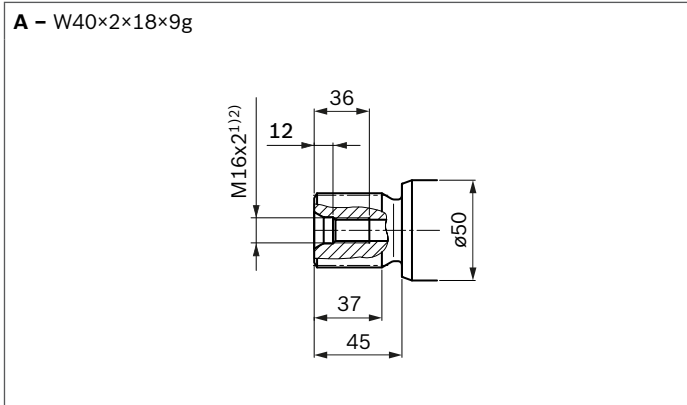

▼ **Splined shaft DIN 5480**

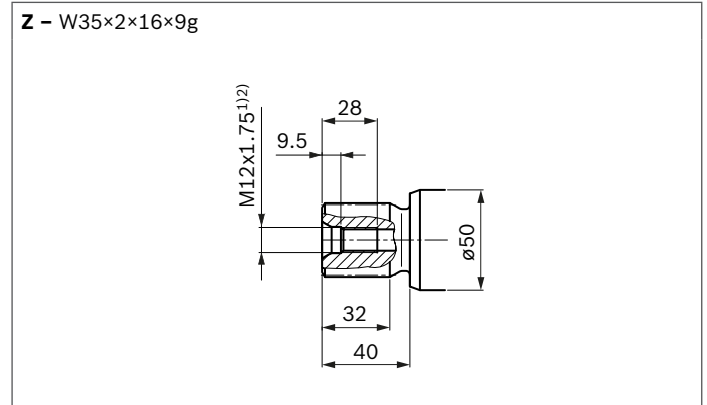

1) For notes on tightening torques, see the instruction manual
 2) Center bore according to DIN 332 (thread according to DIN 13)

▼ **EP.D** – Proportional control, electric,
with pressure control fixed setting

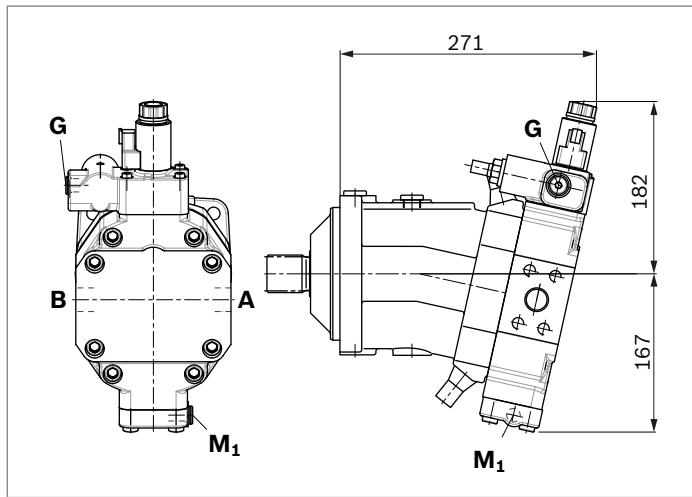

▼ **EP.E** – Proportional control, electric,
with pressure control hydraulic override, two-point

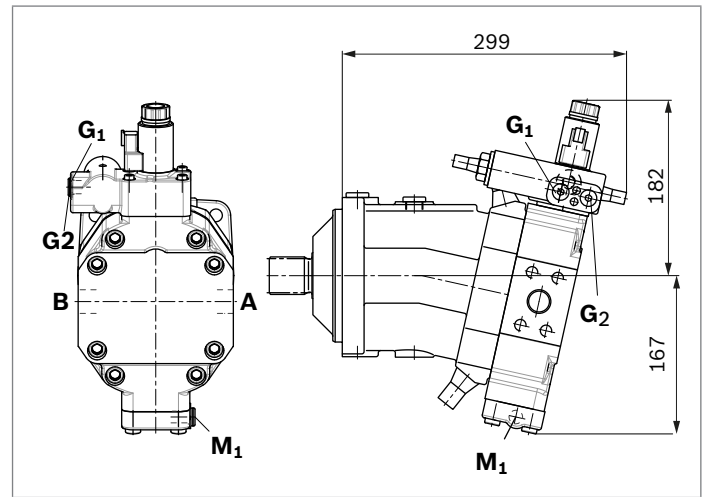

▼ **HD1, HD2** – Proportional control, hydraulic

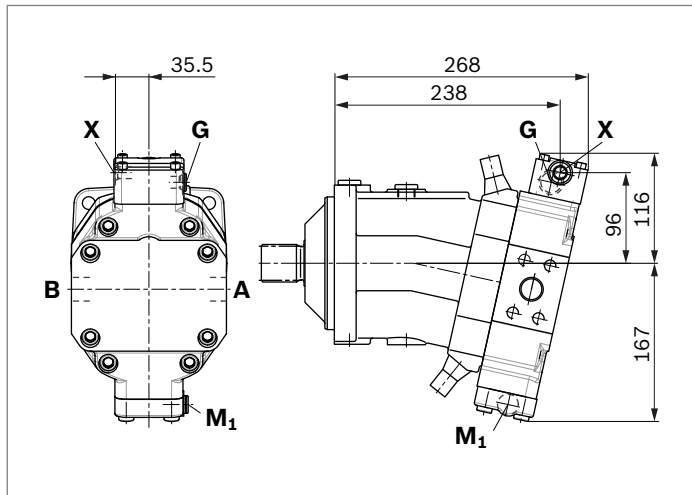

▼ **HD.D** – Proportional control, hydraulic,
with pressure control fixed setting

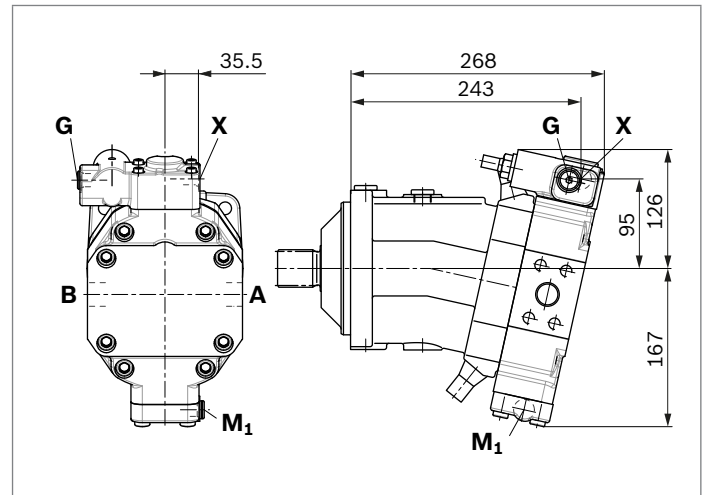

▼ **HD.E** – Proportional control, hydraulic,
with pressure control hydraulic override, two-point

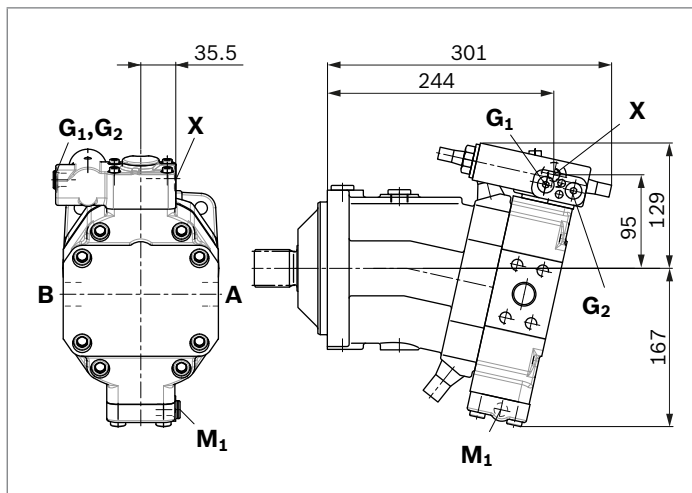

▼ **HZ3** – Two-point control, hydraulic

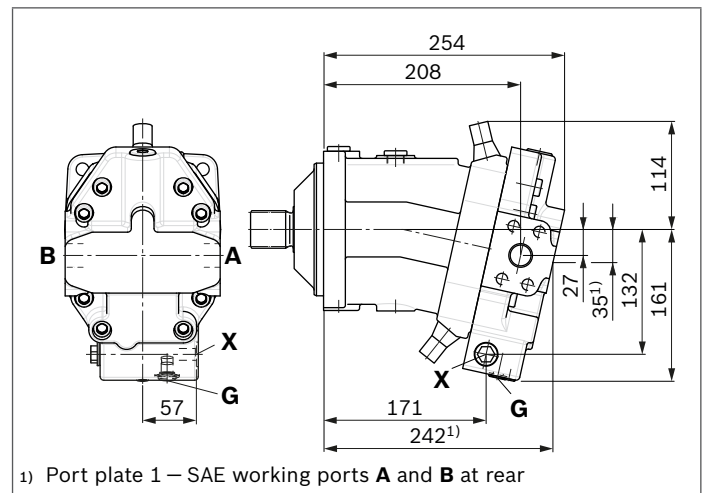

1) Port plate 1 – SAE working ports A and B at rear

▼ **EZ3, EZ4** – Two-point control, electric

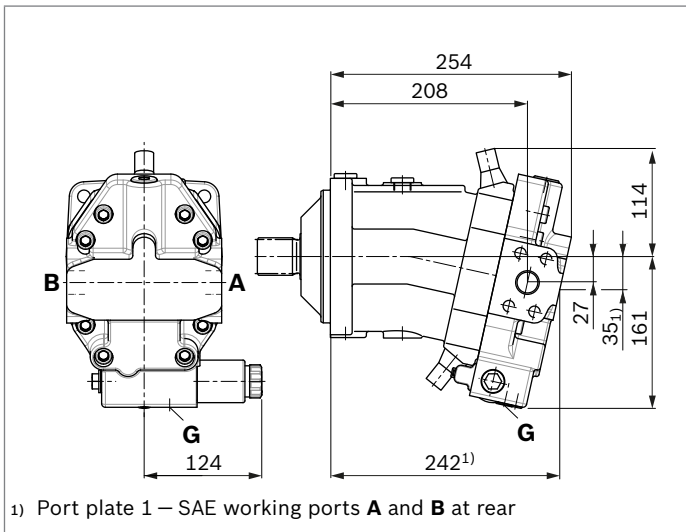

▼ **HA1, HA2 / HA1T, HA2T** – Automatic high-pressure related control, with override, hydraulic remote control, proportional

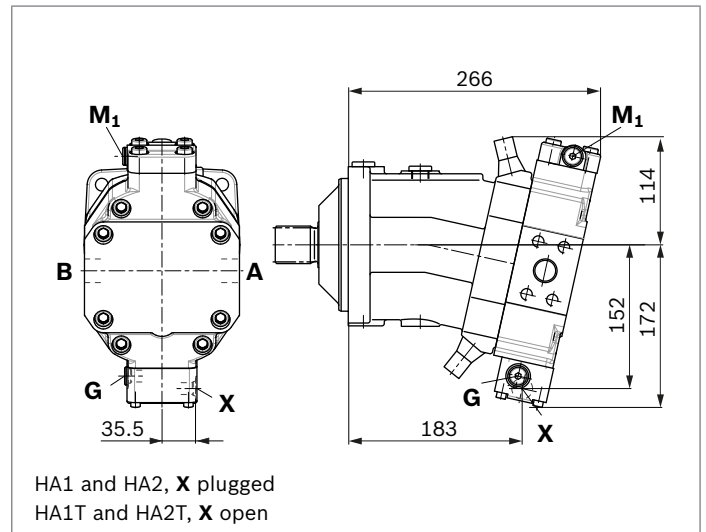

▼ **HA1U1, HA2U2** – Automatic high-pressure related control, with electric override, two-point

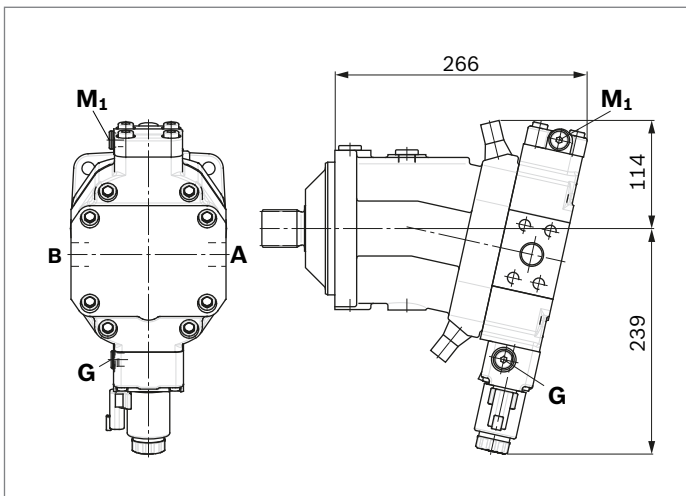

▼ **HA1R1, HA2R2** – Automatic high-pressure related control, with electric override and electric travel direction valve

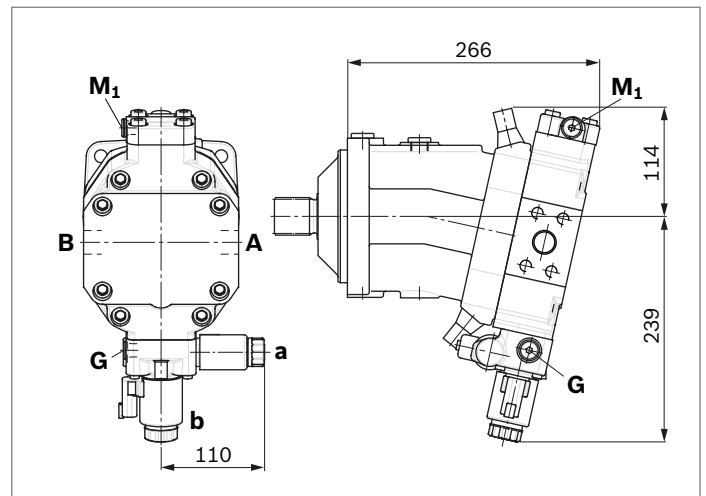

▼ **DA1, DA4** – Automatic speed related control, with hydraulic travel direction valve

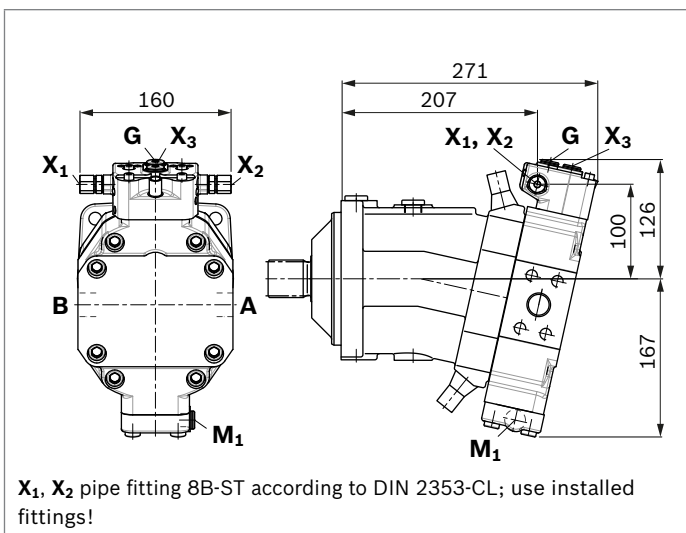

▼ **DA2, DA3, DA5, DA6** – Automatic speed related control, with electric travel direction valve and $V_{g\ max}$ -circuit

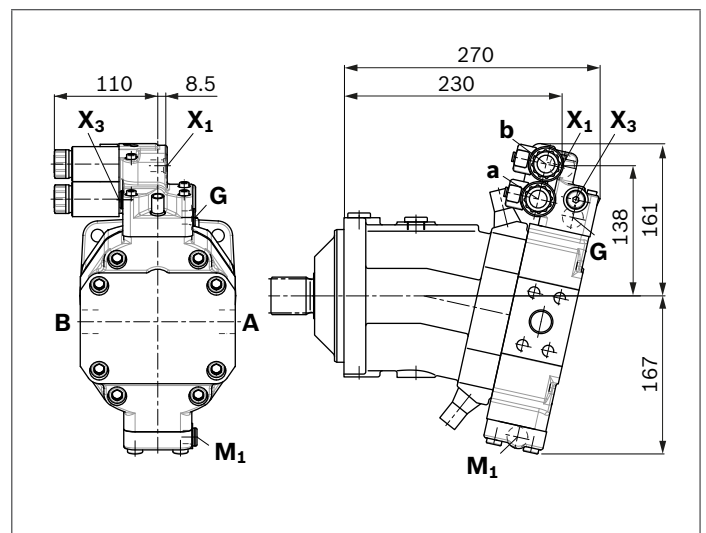

Dimensions, sizes 107

EP1, EP2 – Proportional control, electric

Port plate 2 – SAE working ports **A** and **B** lateral, opposing

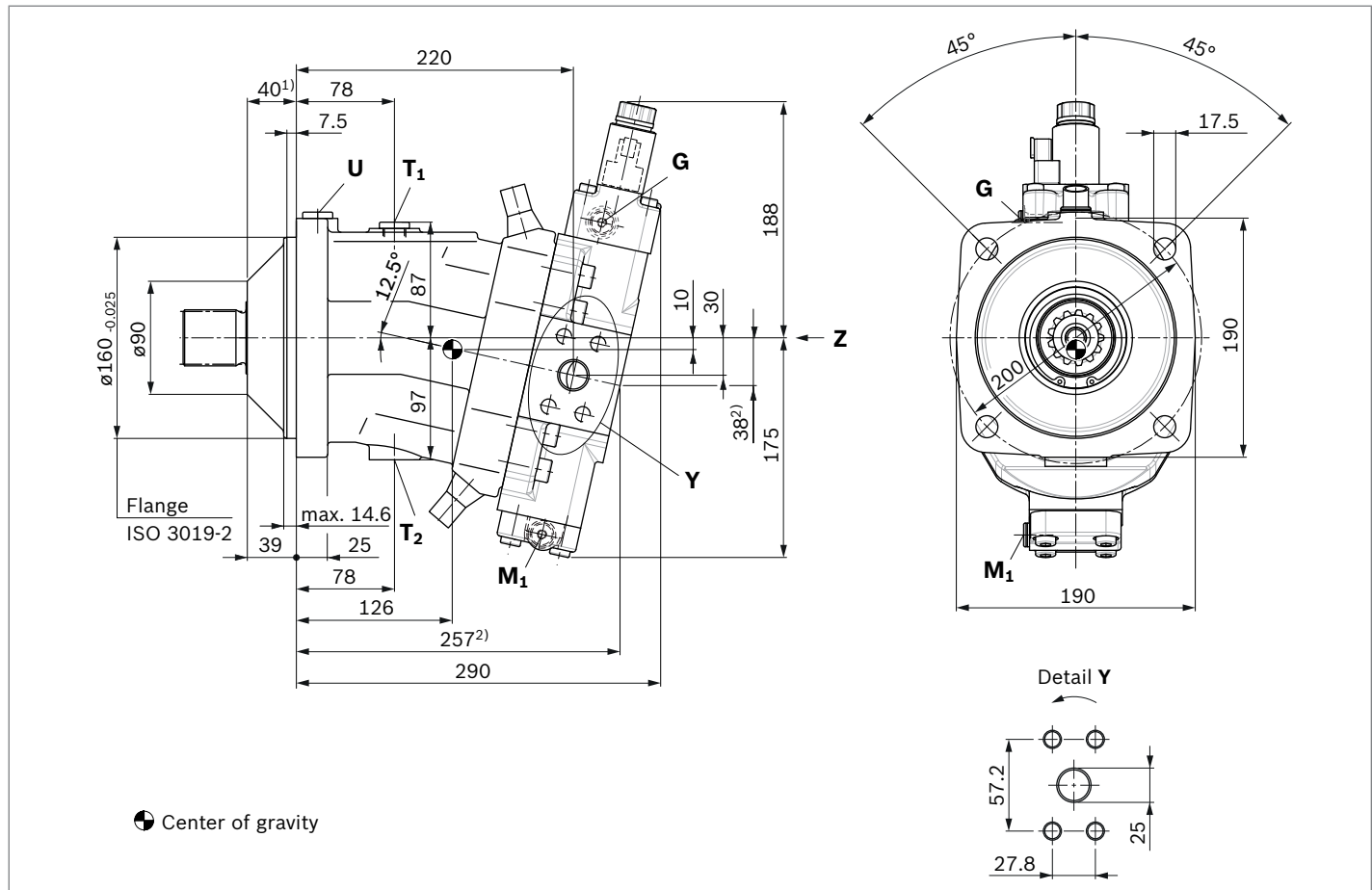

Ports	Standard	Size ³⁾	p_{max} [bar] ⁴⁾	State ⁸⁾
A, B	Working port Fastening thread A/B	SAE J518 ⁵⁾ DIN 13	1 in M12 × 1.75; 17 deep	450 O
T₁	Drain port	DIN 3852 ⁷⁾	M18 × 1.5; 12 deep	3 X ⁶⁾
T₂	Drain port	DIN 3852 ⁷⁾	M18 × 1.5; 12 deep	3 O ⁶⁾
G	Synchronous control	DIN 3852 ⁷⁾	M14 × 1.5; 12 deep	450 X
G₂	2nd pressure setting (HD.E, EP.E)	DIN 3852 ⁷⁾	M14 × 1.5; 12 deep	100 X
U	Bearing flushing	DIN 3852 ⁷⁾	M18 × 1.5; 12 deep	3 X
X	Pilot signal (HP, HZ, HA1T/HA2T)	DIN 3852 ⁷⁾	M14 × 1.5; 12 deep	100 O
X	Pilot signal (HA1, HA2)	DIN 3852 ⁷⁾	M14 × 1.5; 12 deep	3 X
X₁, X₂	Pilot signal (DA1, DA4)	DIN 2353-CL	8B-ST	40 O
X₁	Pilot signal (DA2, DA3, DA5, DA6)	DIN 3852 ⁷⁾	M14 × 1.5; 12 deep	40 O
X₃	Pilot signal (DA2, DA3, DA5, DA6)	DIN 3852 ⁷⁾	M14 × 1.5; 12 deep	40 X
M₁	Stroking chamber measurement	DIN 3852 ⁷⁾	M14 × 1.5; 12 deep	450 X

1) To shaft collar

2) Port plate 1 – SAE working ports **A** and **B** at rear

3) For notes on tightening torques, see the instruction manual

4) Depending on the application, momentary pressure peaks can occur. Keep this in mind when selecting measuring devices and fittings.

5) Only dimensions according to SAE J518, metric fastening thread is a deviation from the standard

6) Depending on installation position, **T₁** or **T₂** must be connected (see also installation instructions on page 80).

7) The countersink can be deeper than as specified in the standard.

8) O = Must be connected (plugged when delivered)

X = Plugged (in normal operation)

▼ **Location of the working ports on the port plates (view Z)**

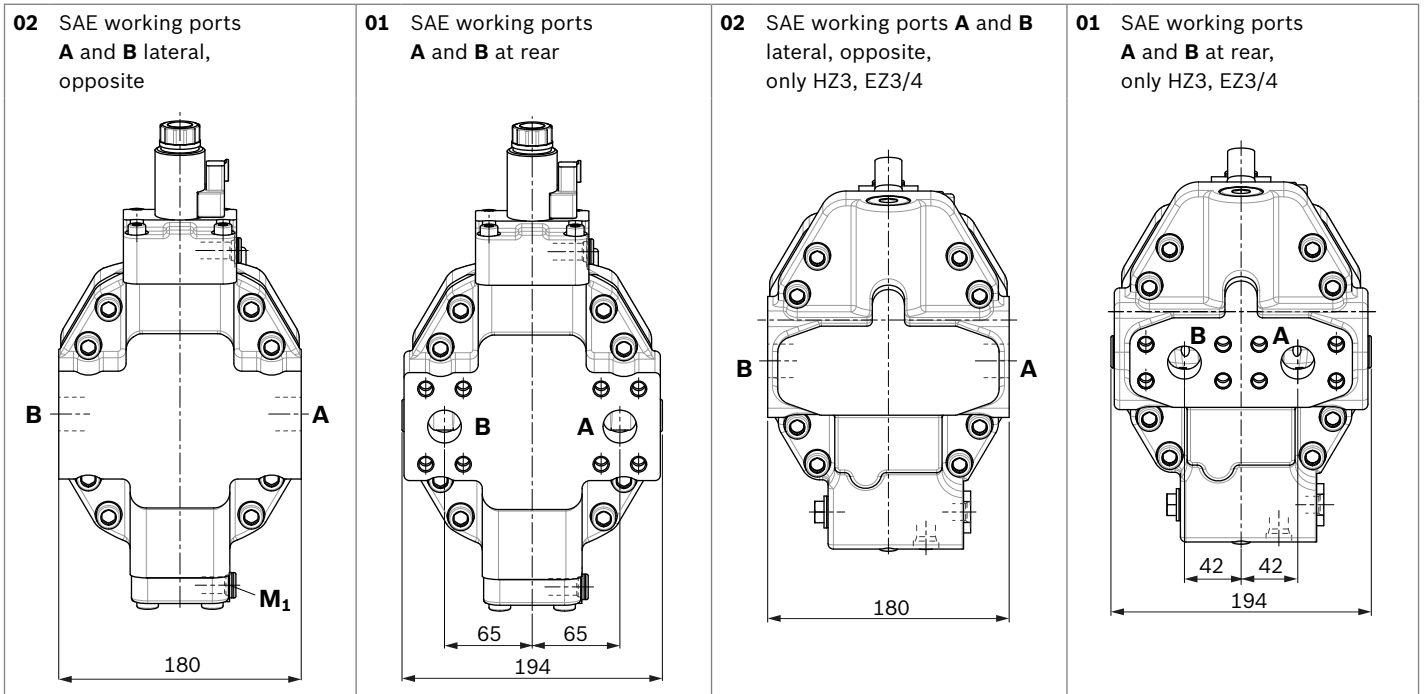

▼ **Splined shaft DIN 5480**

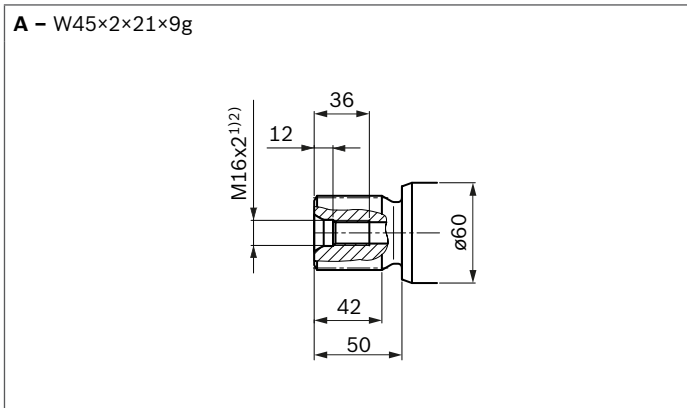

▼ **Splined shaft DIN 5480**

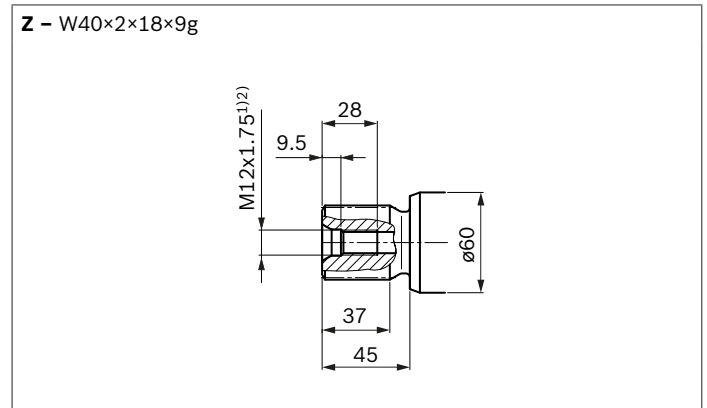

1) For notes on tightening torques, see the instruction manual
 2) Center bore according to DIN 332 (thread according to DIN 13)

▼ **EP.D** – Proportional control, electric,
 with pressure control fixed setting

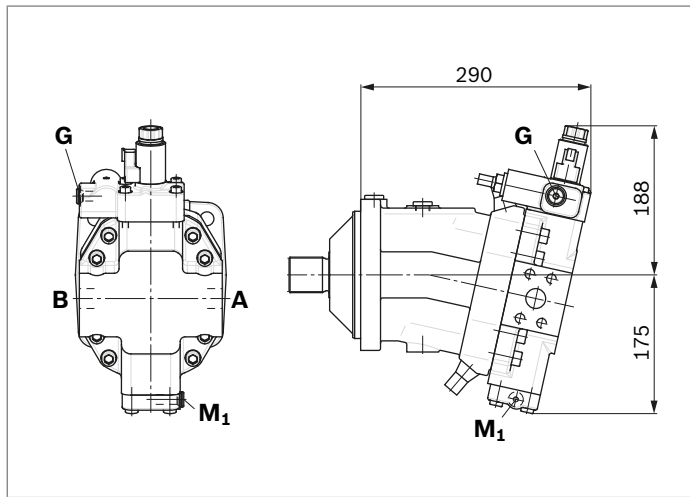

▼ **EP.E** – Proportional control, electric,
 with pressure control hydraulic override, two-point

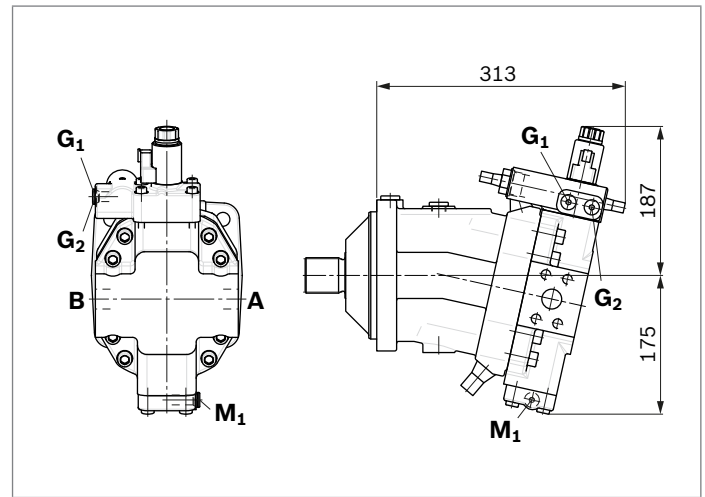

▼ **HD1, HD2** – Proportional control, hydraulic

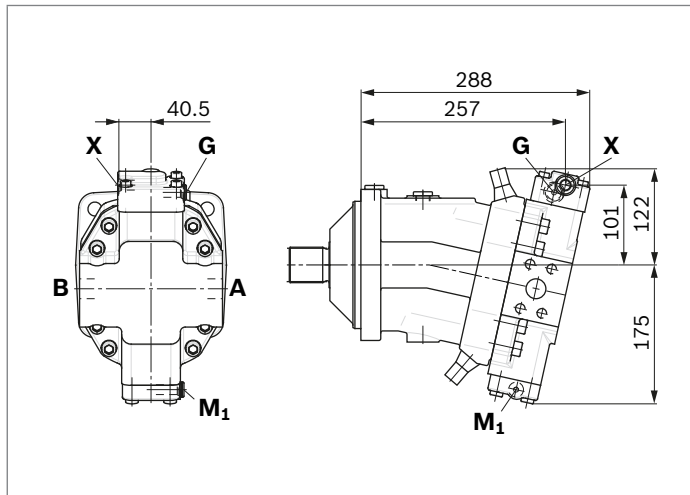

▼ **HD.D** – Proportional control, hydraulic,
 with pressure control fixed setting

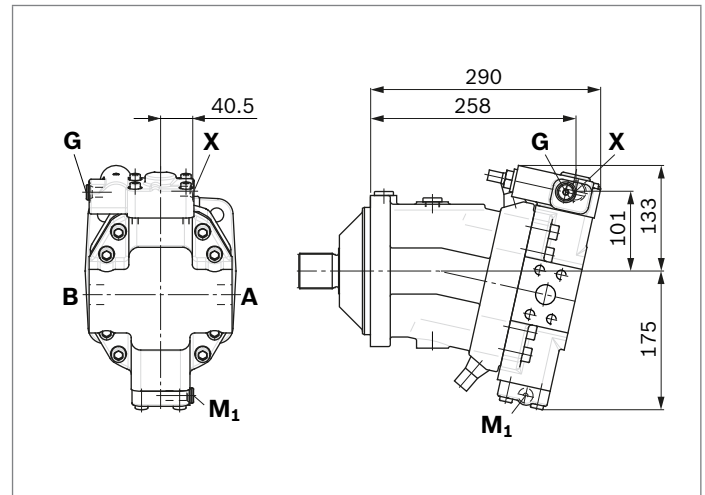

▼ **HD.E** – Proportional control, hydraulic,
 with pressure control hydraulic override, two-point

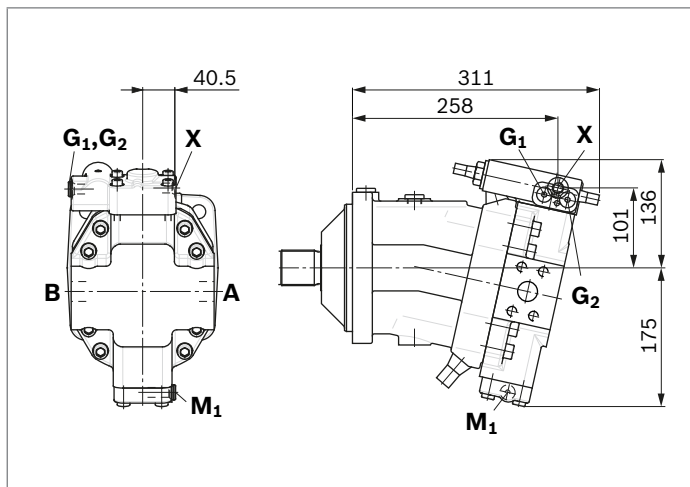

▼ **HZ3** – Two-point control, hydraulic

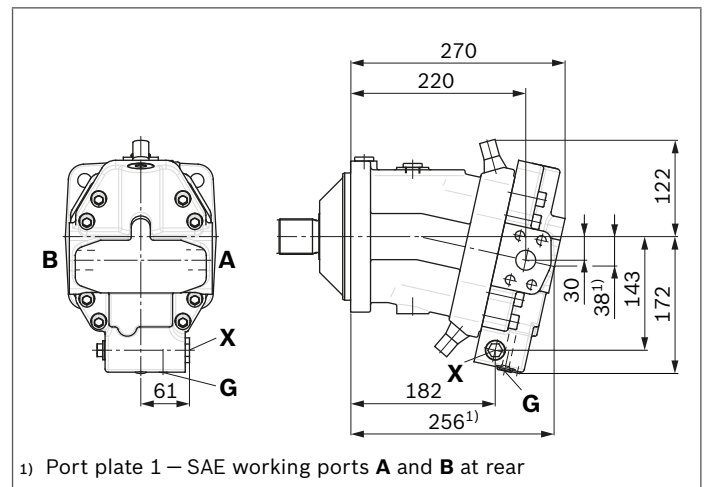

1) Port plate 1 – SAE working ports **A** and **B** at rear

▼ **EZ3, EZ4** – Two-point control, electric

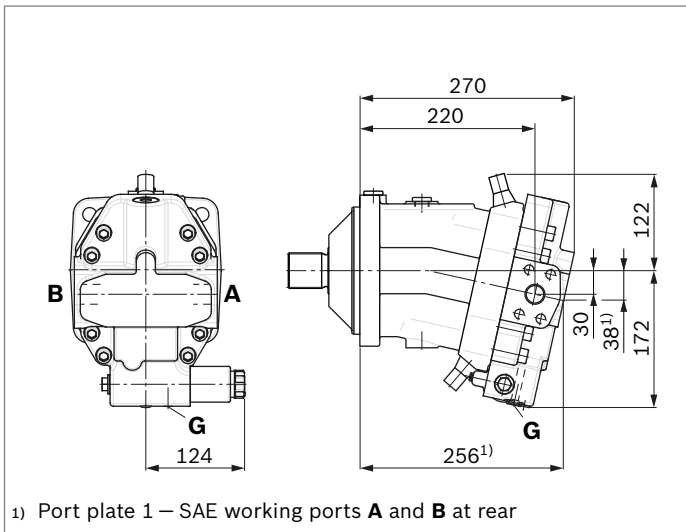

▼ **HA1, HA2 / HA1T, HA2T** – Automatic high-pressure related control, with override, hydraulic remote control, proportional

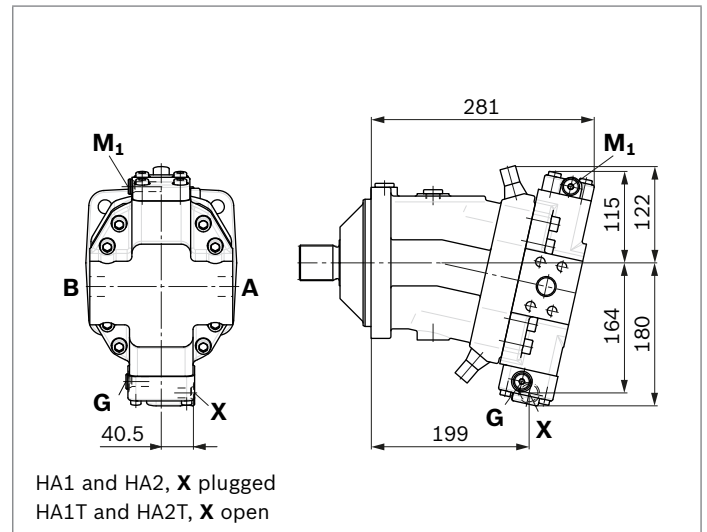

▼ **HA1U1, HA2U2** – Automatic high-pressure related control, with electric override, two-point

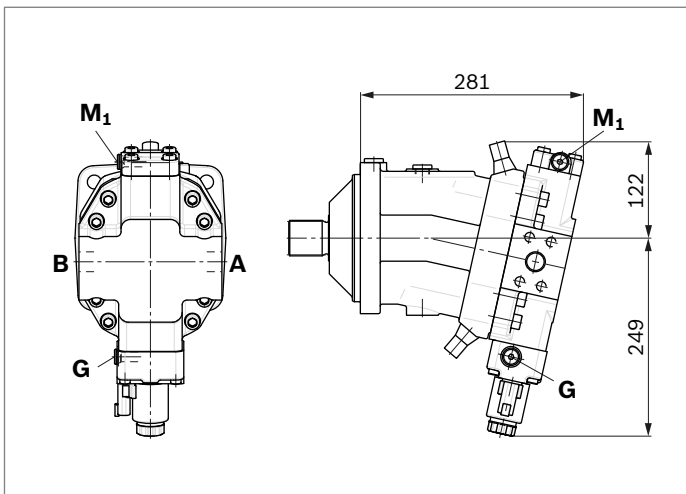

▼ **HA1R1, HA2R2** – Automatic high-pressure related control, with electric override and electric travel direction valve

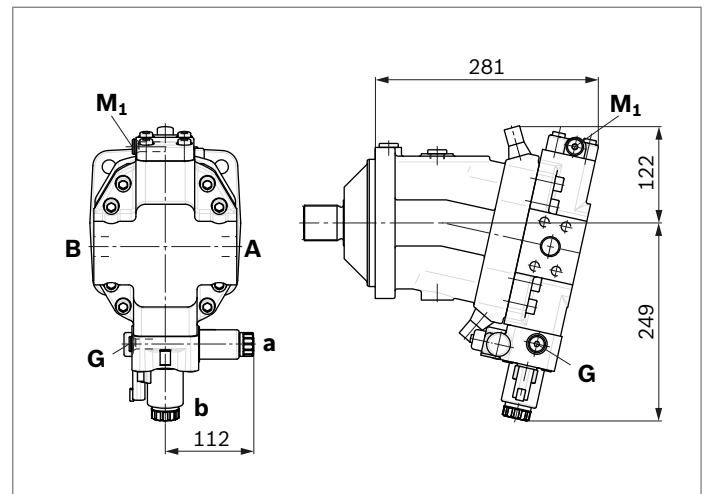

▼ **DA1, DA4** – Automatic speed related control, with hydraulic travel direction valve

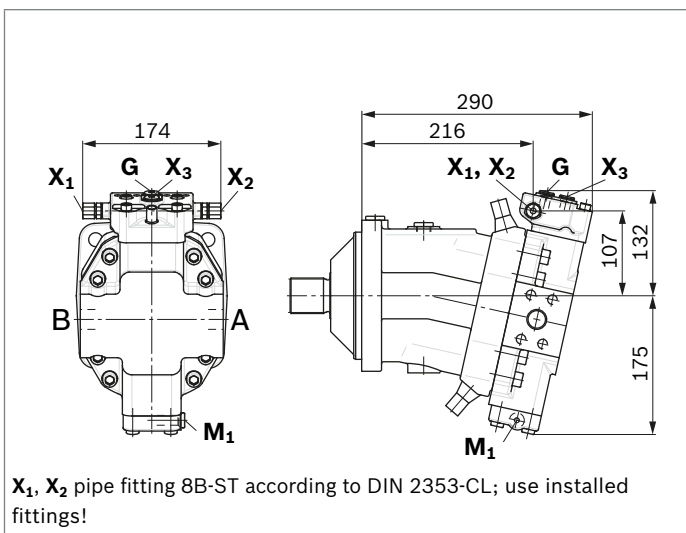

▼ **DA2, DA3, DA5, DA6** – Automatic speed related control, with electric travel direction valve and $V_{g\ max}$ -circuit

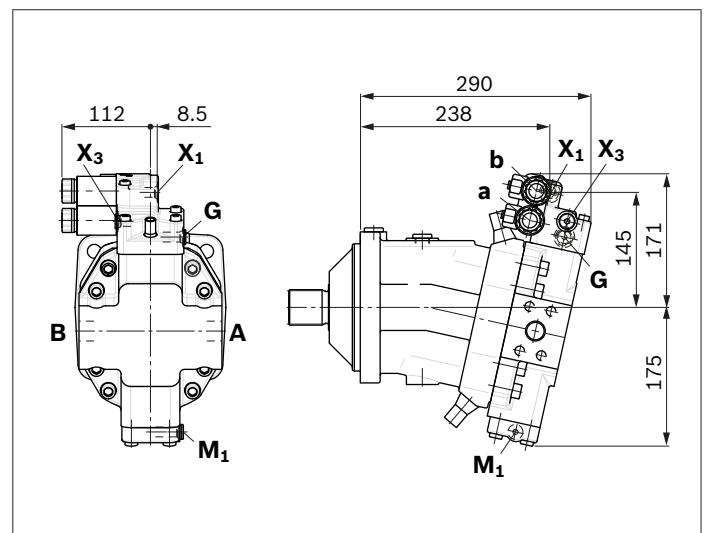

▼ **Location of the working ports on the port plates (view Z)**

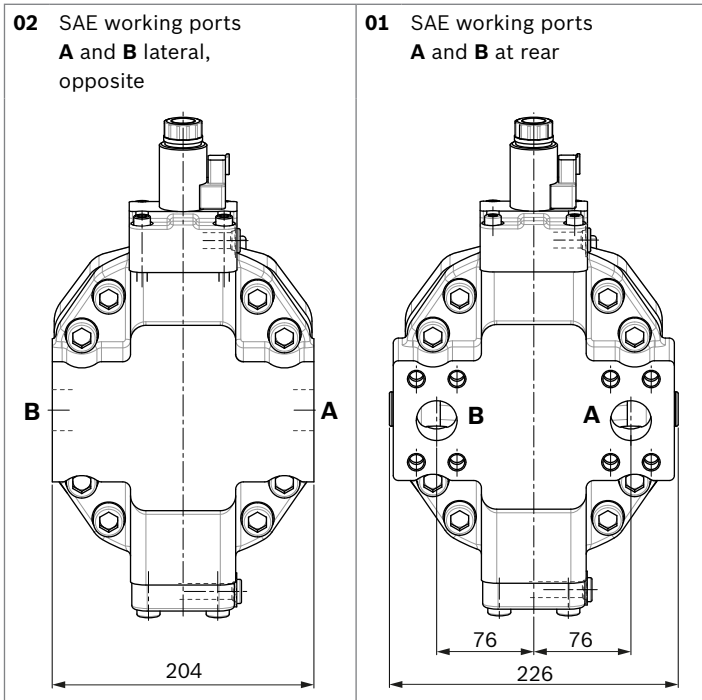

▼ **Splined shaft DIN 5480**

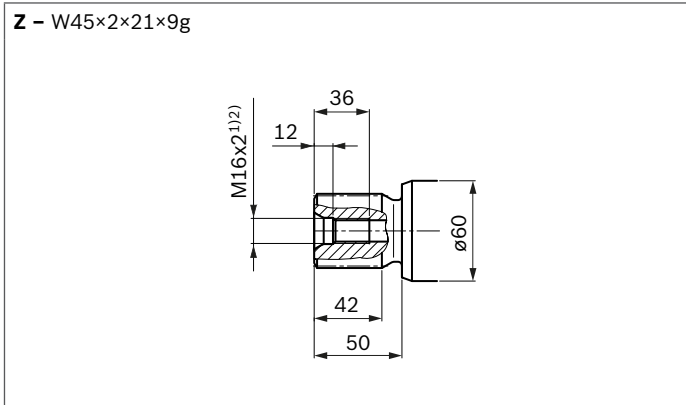

1) For notes on tightening torques, see the instruction manual
 2) Center bore according to DIN 332 (thread according to DIN 13)

▼ **EP.D** – Proportional control, electric,
 with pressure control fixed setting

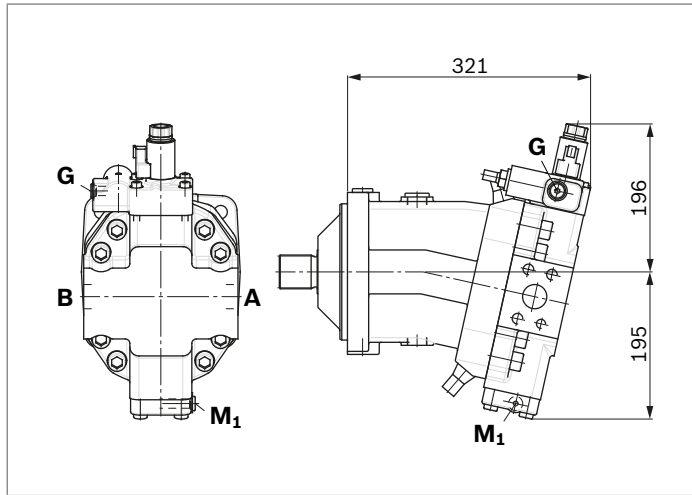

▼ **EP.E** – Proportional control, electric,
 with pressure control hydraulic override, two-point

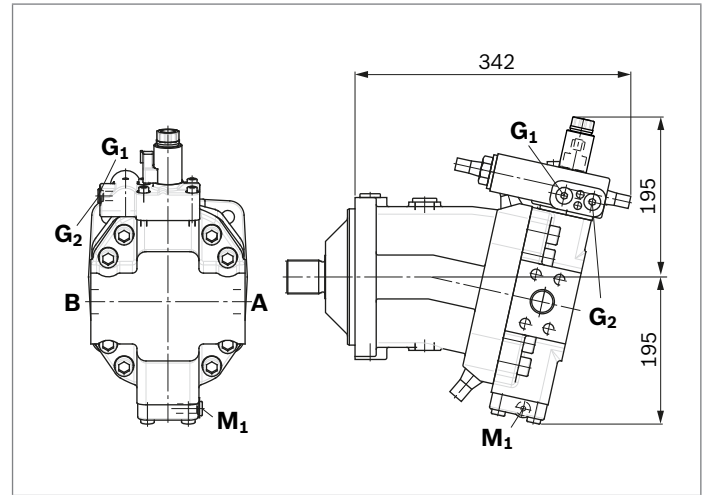

▼ **HD1, HD2** – Proportional control, hydraulic

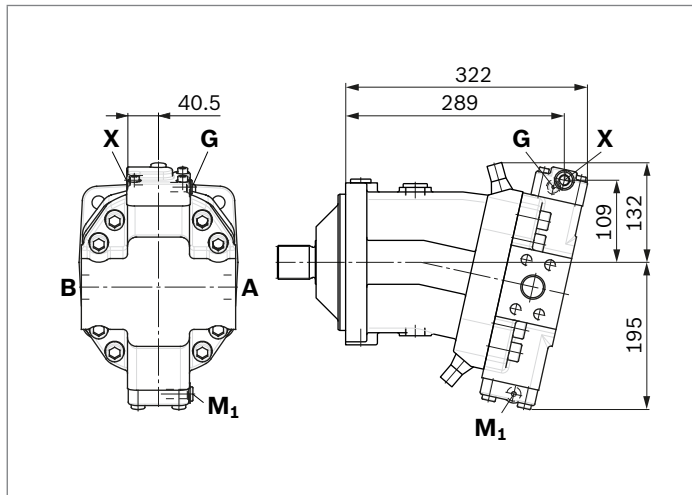

▼ **HD.D** – Proportional control, hydraulic,
 with pressure control fixed setting

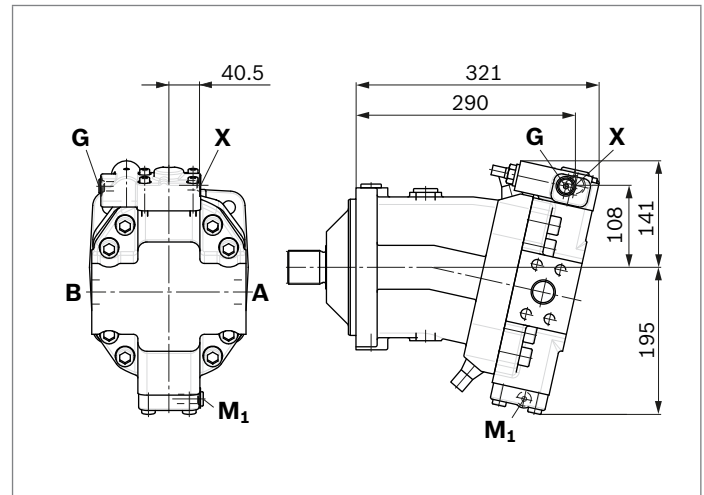

▼ **HD.E** – Proportional control, hydraulic,
 with pressure control hydraulic override, two-point

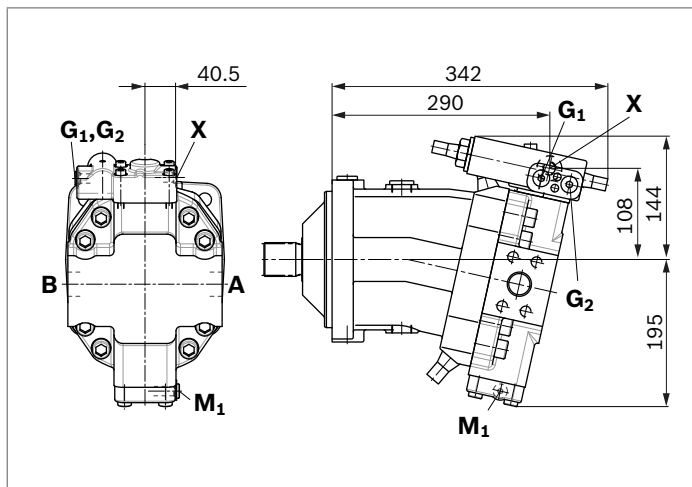

▼ **HZ1** – Two-point control, hydraulic

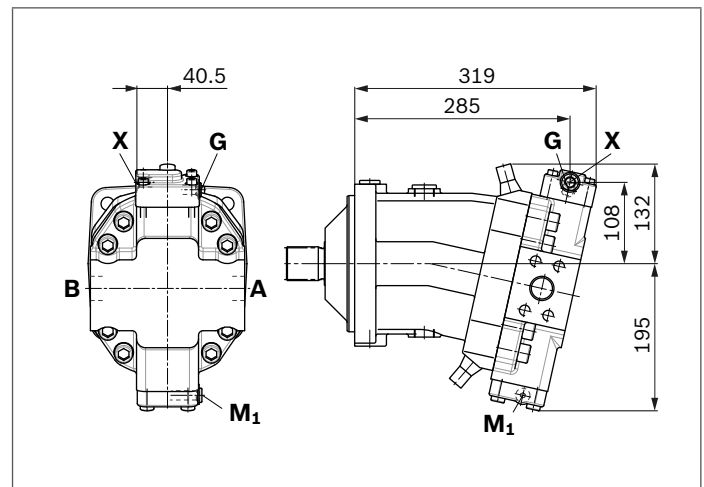

▼ **EZ1, EZ2** – Two-point control, electric

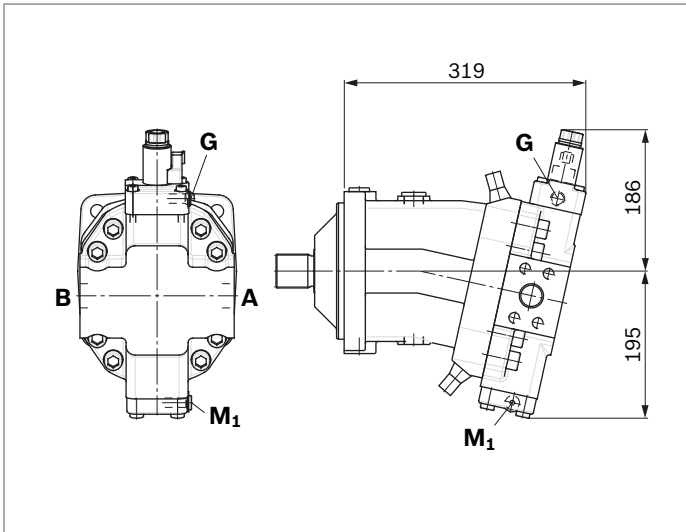

▼ **HA1, HA2 / HA1T, HA2T** – Automatic high-pressure related control, with override, hydraulic remote control, proportional

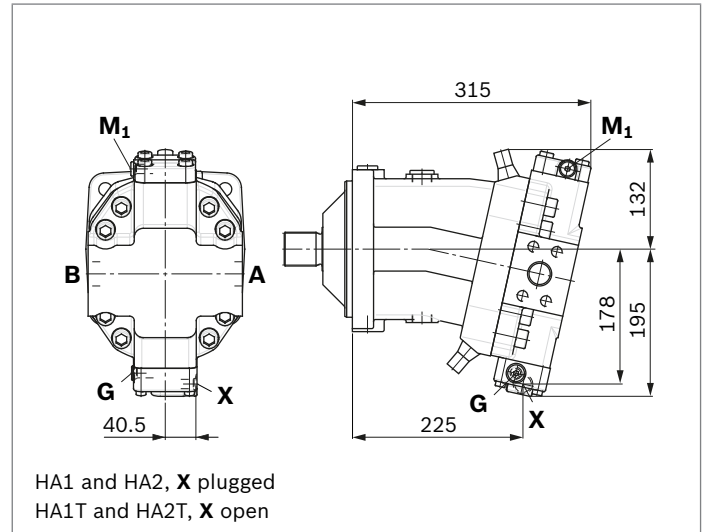

▼ **HA1U1, HA2U2** – Automatic high-pressure related control, with electric override, two-point

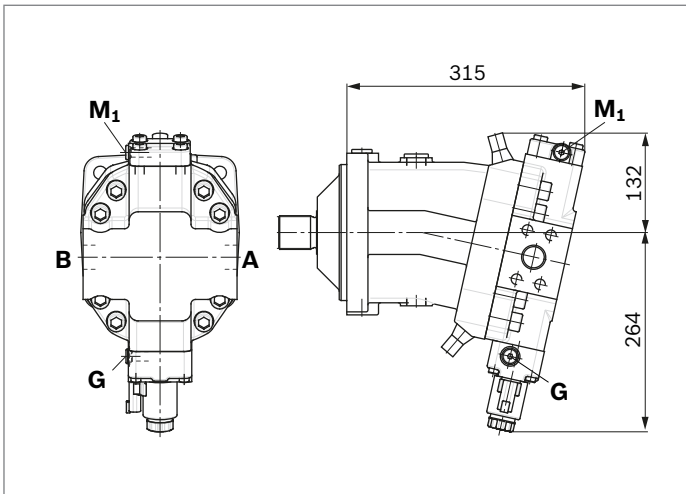

▼ **HA1R1, HA2R2** – Automatic high-pressure related control, with electric override and electric travel direction valve

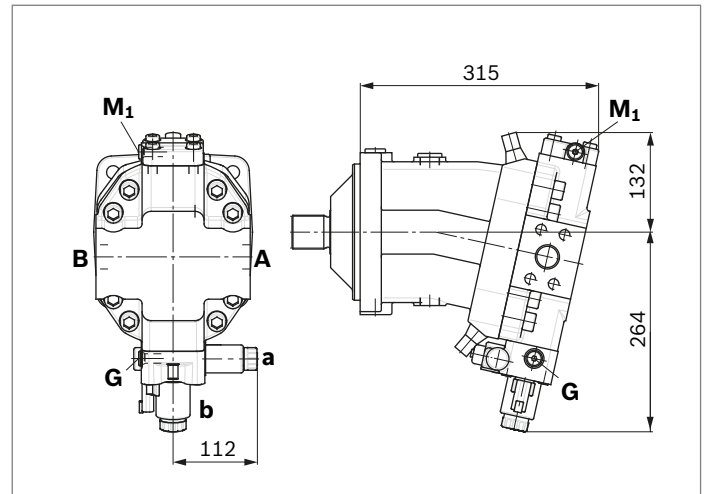

▼ **DA1, DA4** – Automatic speed related control, with hydraulic travel direction valve

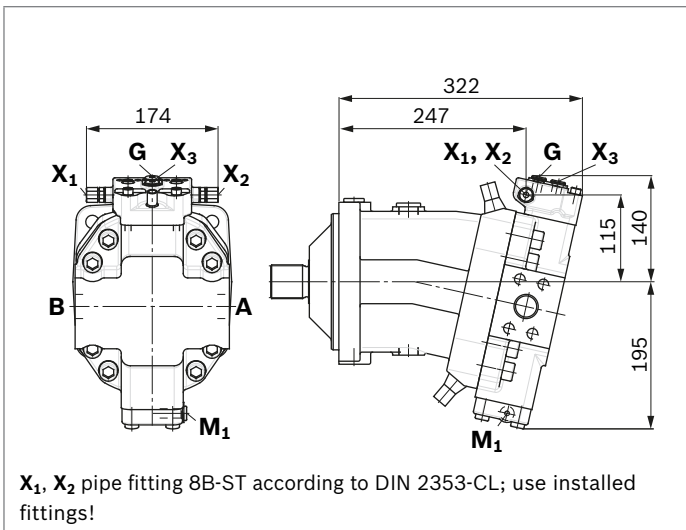

▼ **DA2, DA3, DA5, DA6** – Automatic speed related control, with electric travel direction valve and V_{g max}-circuit

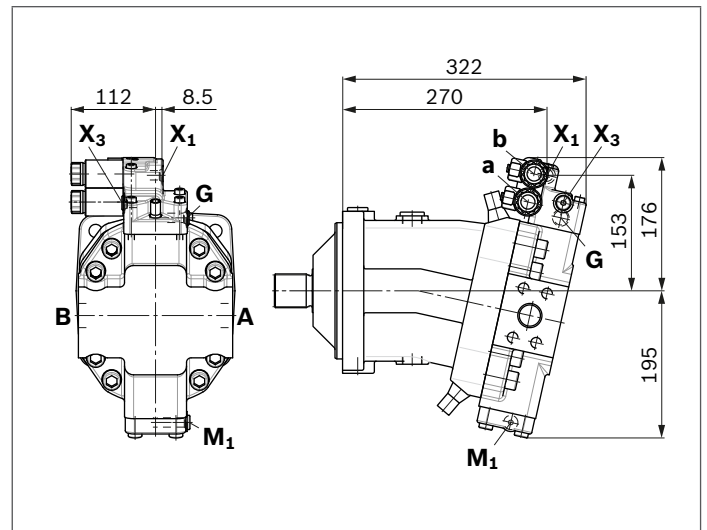

Dimensions, sizes 160

EP1, EP2 – Proportional control, electric

Port plate 2 – SAE working ports **A** and **B** lateral, opposing

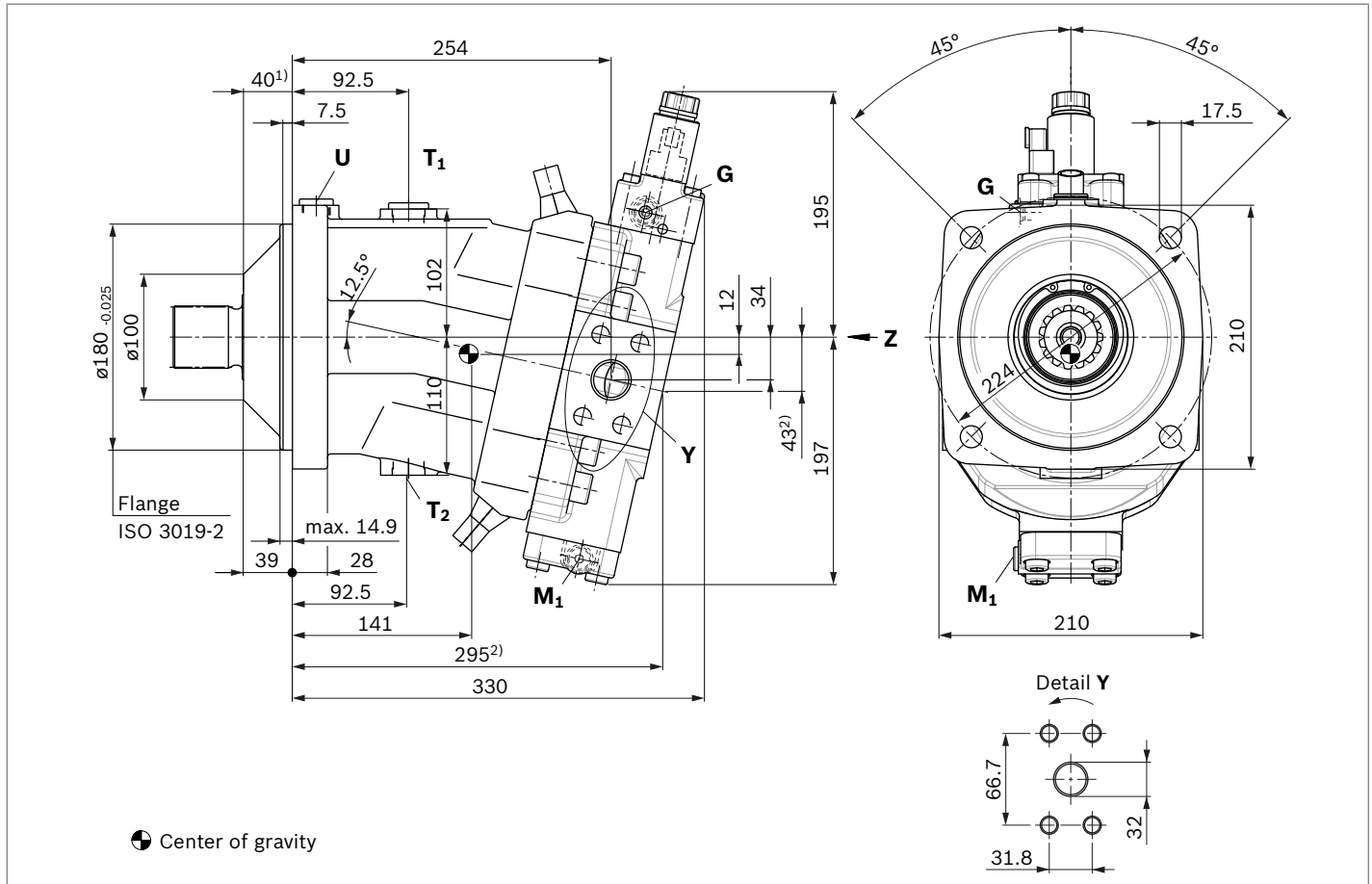

Ports	Standard	Size ³⁾	p_{max} [bar] ⁴⁾	State ⁸⁾
A, B	Working port Fastening thread A/B	SAE J518 ⁵⁾ DIN 13	1 1/4 in M14 × 2; 19 deep	450 O
T₁	Drain port	DIN 3852 ⁷⁾	M26 × 1.5; 16 deep	3 X ⁶⁾
T₂	Drain port	DIN 3852 ⁷⁾	M26 × 1.5; 16 deep	3 O ⁶⁾
G	Synchronous control	DIN 3852 ⁷⁾	M14 × 1.5; 12 deep	450 X
G₂	2nd pressure setting (HD.E, EP.E)	DIN 3852 ⁷⁾	M14 × 1.5; 12 deep	100 X
U	Bearing flushing	DIN 3852 ⁷⁾	M22 × 1.5; 14 deep	3 X
X	Pilot signal (HP, HZ, HA1T/HA2T)	DIN 3852 ⁷⁾	M14 × 1.5; 12 deep	100 O
X	Pilot signal (HA1, HA2)	DIN 3852 ⁷⁾	M14 × 1.5; 12 deep	3 X
X₁, X₂	Pilot signal (DA1, DA4)	DIN 2353-CL	8B-ST	40 O
X₁	Pilot signal (DA2, DA3, DA5, DA6)	DIN 3852 ⁷⁾	M14 × 1.5; 12 deep	40 O
X₃	Pilot signal (DA2, DA3, DA5, DA6)	DIN 3852 ⁷⁾	M14 × 1.5; 12 deep	40 X
M₁	Stroking chamber measurement	DIN 3852 ⁷⁾	M14 × 1.5; 12 deep	450 X

1) To shaft collar

2) Port plate 1 – SAE working ports **A** and **B** at rear

3) For notes on tightening torques, see the instruction manual

4) Depending on the application, momentary pressure peaks can occur. Keep this in mind when selecting measuring devices and fittings.

5) Only dimensions according to SAE J518, metric fastening thread is a deviation from the standard

6) Depending on installation position, **T₁** or **T₂** must be connected (see also installation instructions on page 80).

7) The countersink can be deeper than as specified in the standard.

8) O = Must be connected (plugged when delivered)

X = Plugged (in normal operation)

▼ **Location of the working ports on the port plates (view Z)**

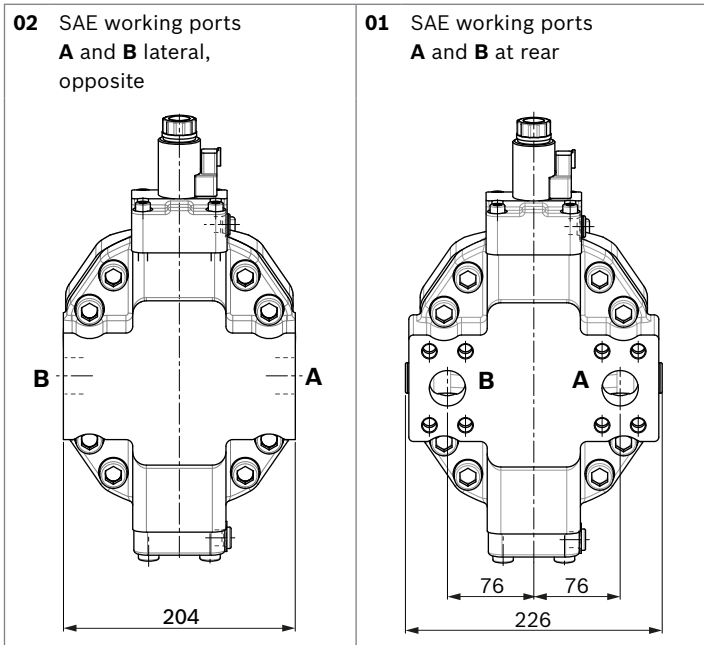

▼ **Splined shaft DIN 5480**

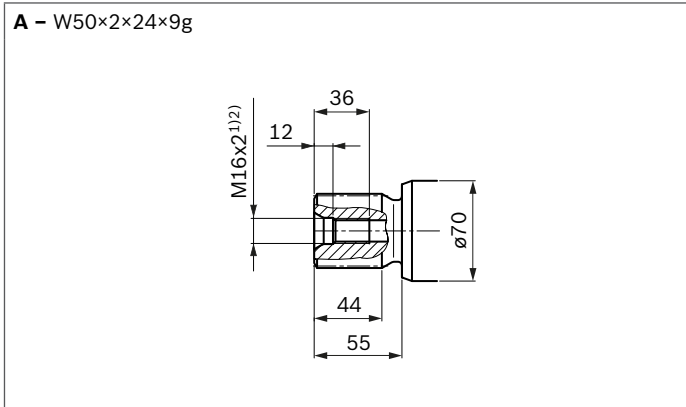

▼ **Splined shaft DIN 5480**

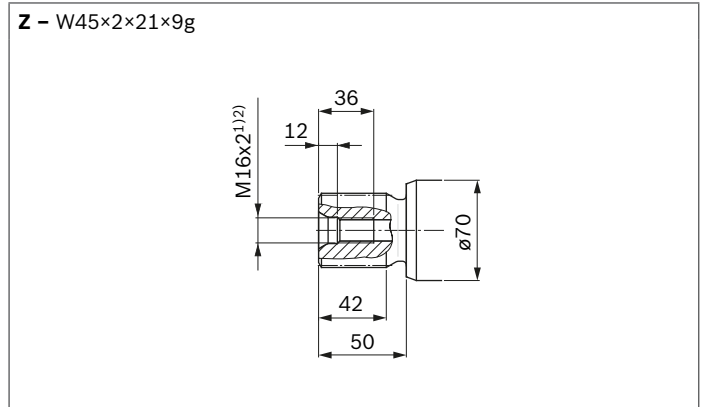

1) For notes on tightening torques, see the instruction manual
 2) Center bore according to DIN 332 (thread according to DIN 13)

▼ **EP.D** – Proportional control, electric,
 with pressure control fixed setting

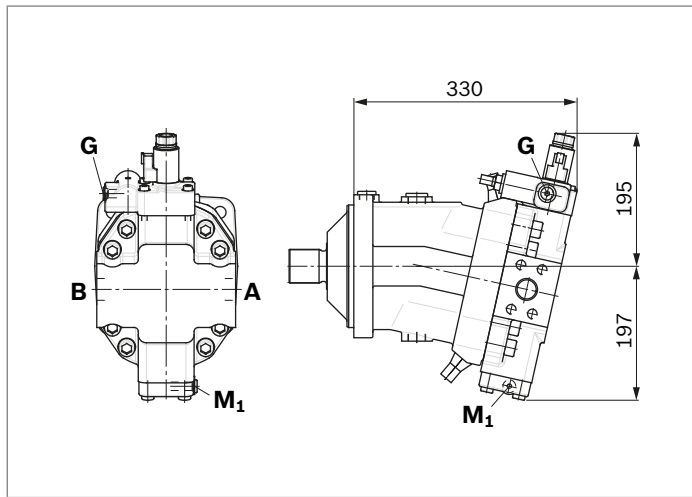

▼ **EP.E** – Proportional control, electric,
 with pressure control hydraulic override, two-point

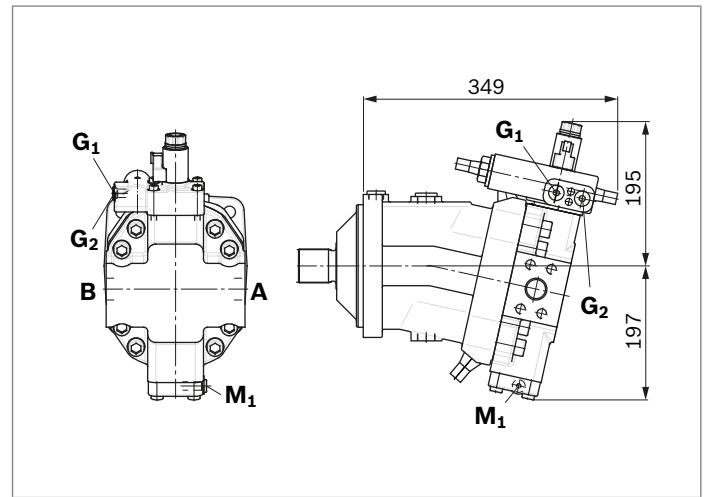

▼ **HD1, HD2** – Proportional control, hydraulic

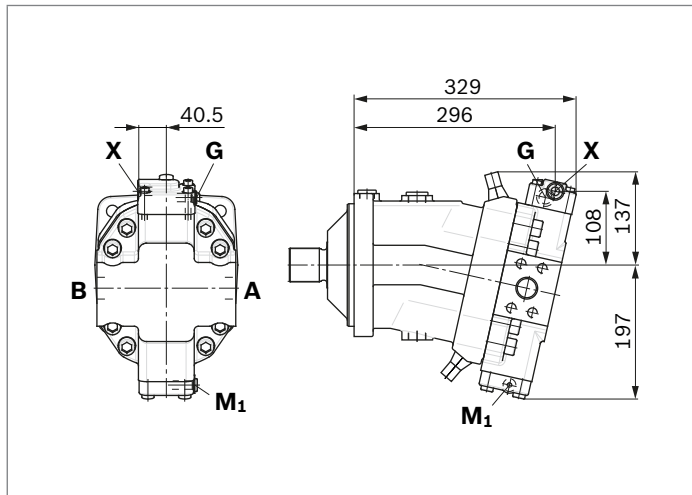

▼ **HD.D** – Proportional control, hydraulic,
 with pressure control fixed setting

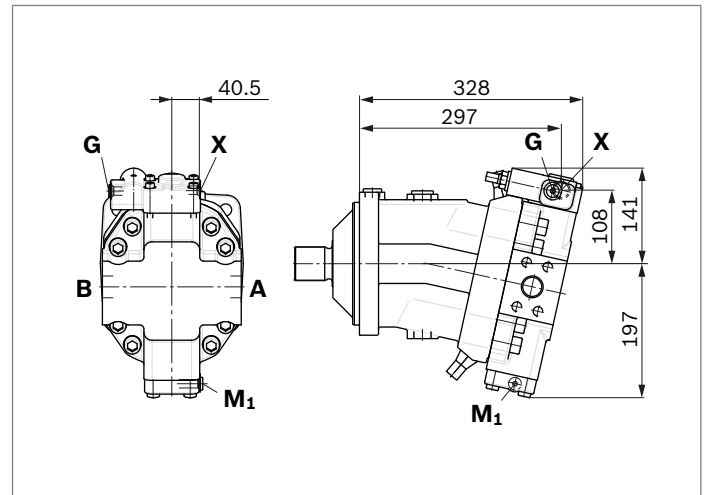

▼ **HD.E** – Proportional control, hydraulic,
 with pressure control hydraulic override, two-point

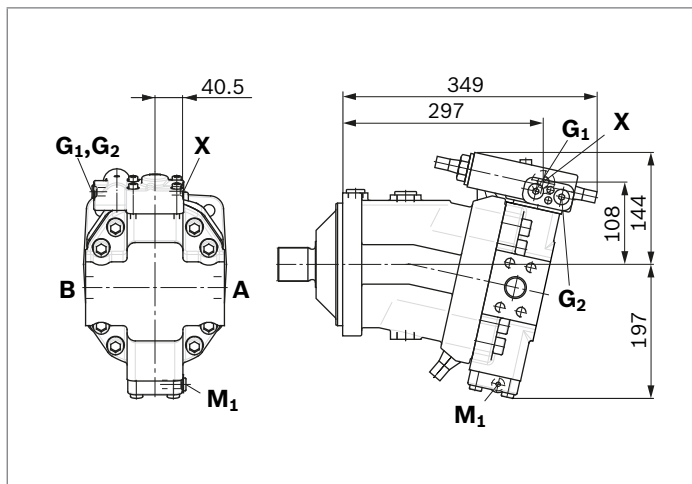

▼ **HZ1** – Two-point control, hydraulic

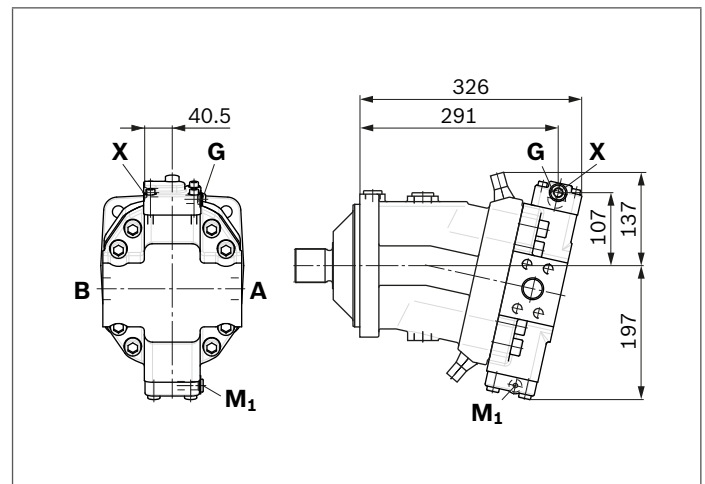

▼ **EZ1, EZ2** – Two-point control, electric

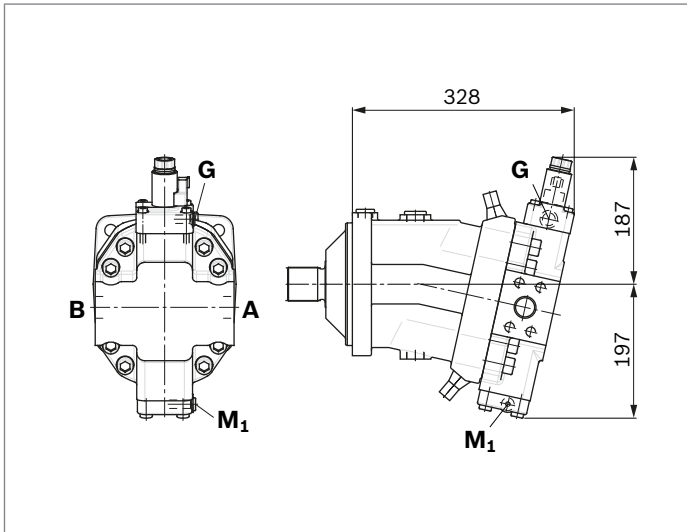

▼ **HA1, HA2 / HA1T, HA2T** – Automatic high-pressure related control, with override, hydraulic remote control, proportional

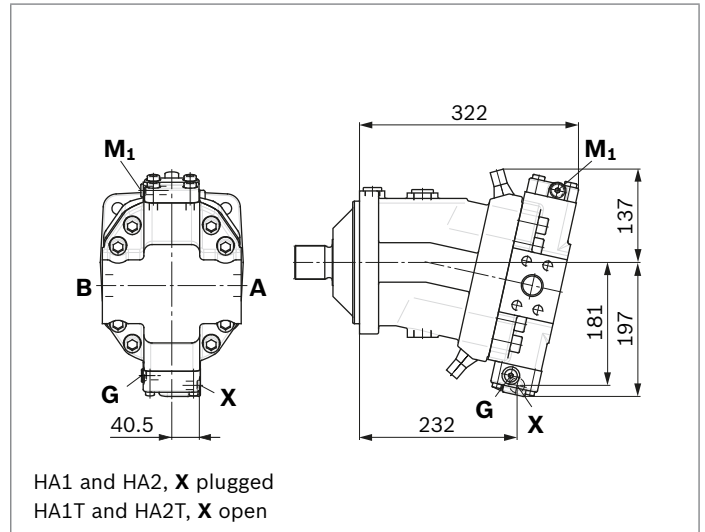

▼ **HA1U1, HA2U2** – Automatic high-pressure related control, with electric override, two-point

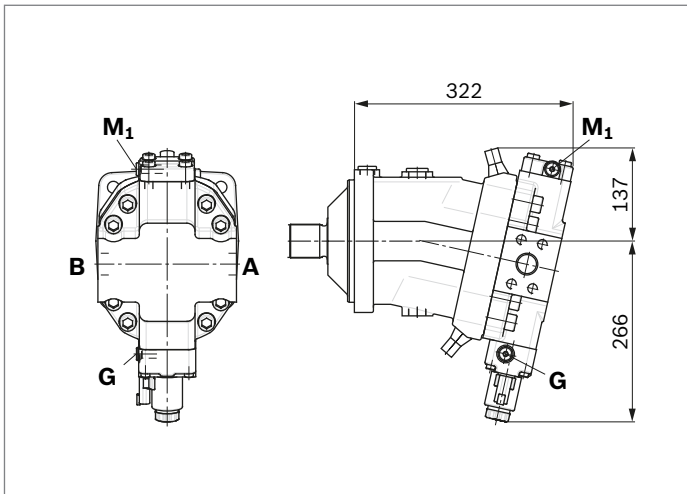

▼ **HA1R1, HA2R2** – Automatic high-pressure related control, with electric override and electric travel direction valve

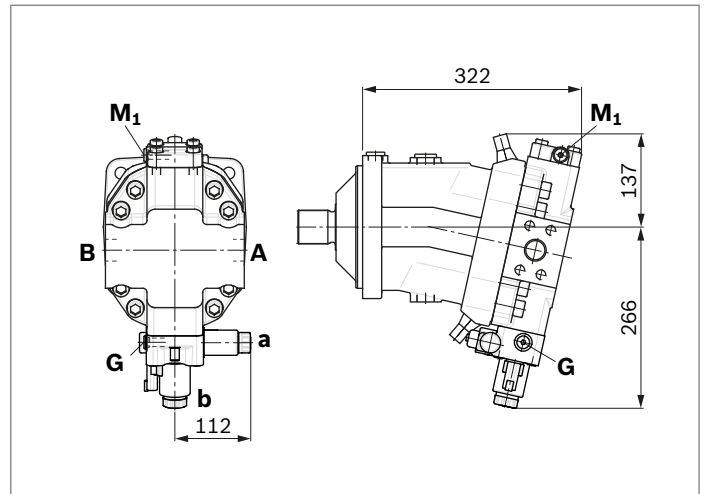

▼ **DA1, DA4** – Automatic speed related control, with hydraulic travel direction valve

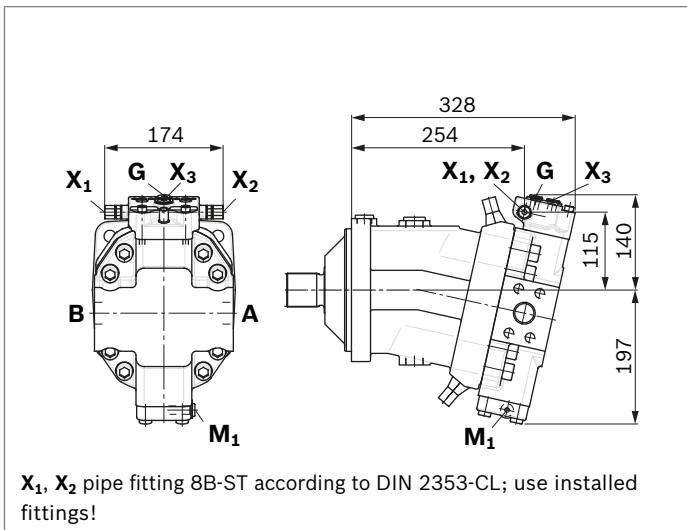

▼ **DA2, DA3, DA5, DA6** – Automatic speed related control, with electric travel direction valve and V_{g max}-circuit

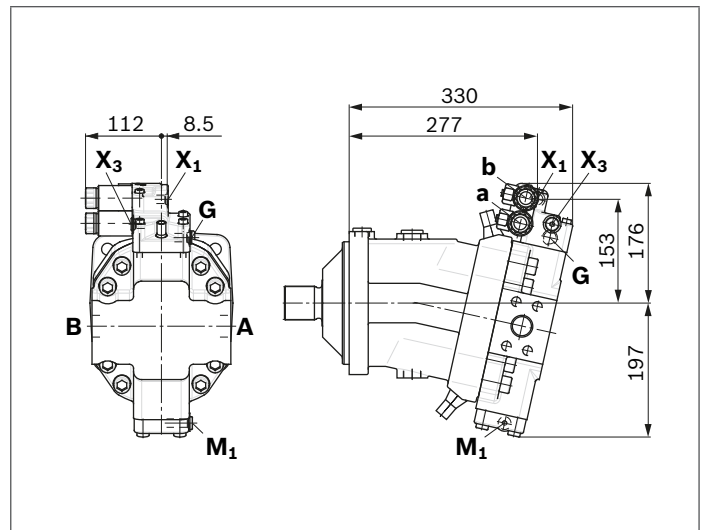

Dimensions, sizes 200

EP1, EP2 – Proportional control, electric

Port plate 2 – SAE working ports **A** and **B** lateral, opposing

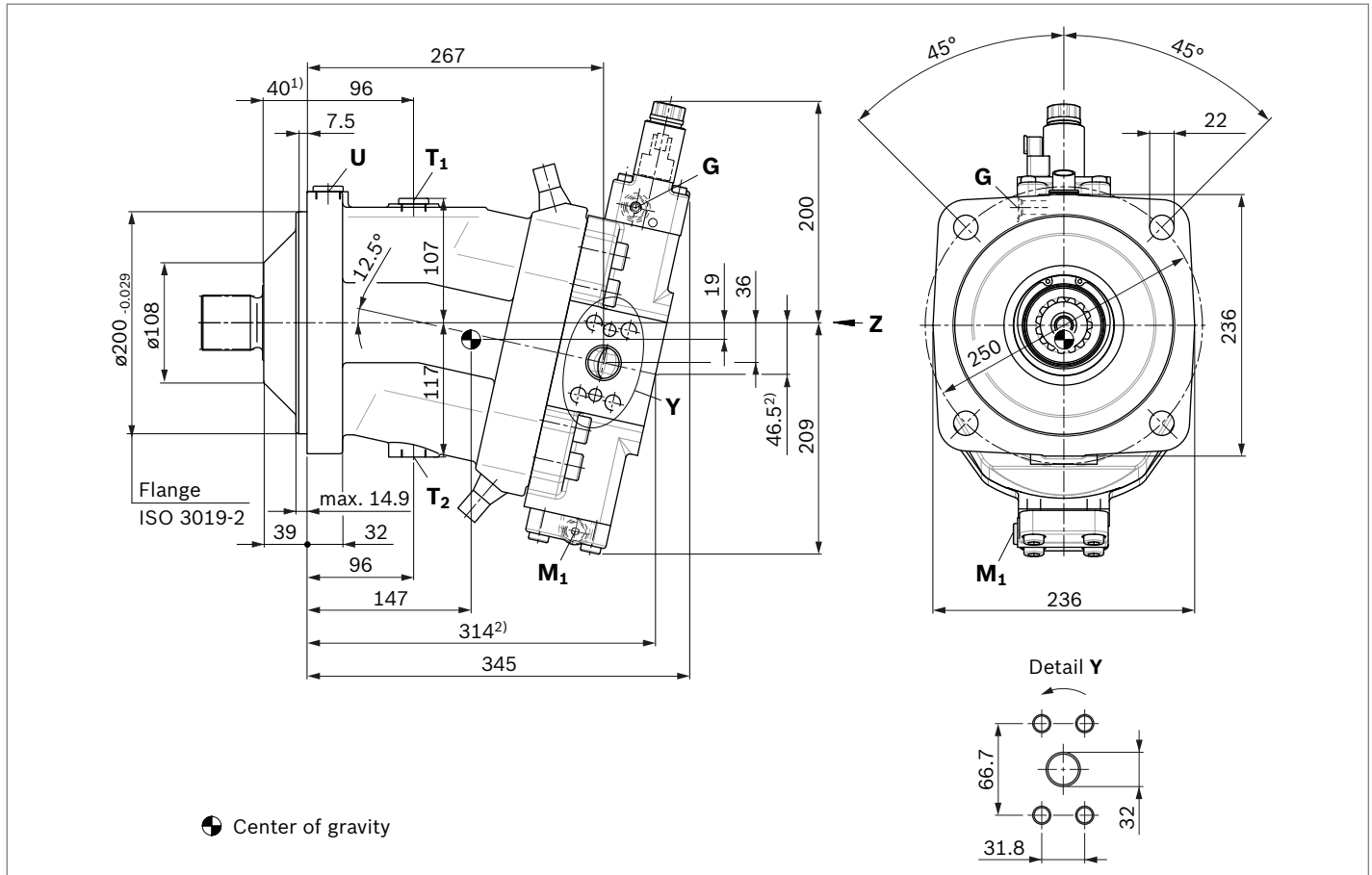

Ports	Standard	Size ³⁾	p_{max} [bar] ⁴⁾	State ⁸⁾
A, B	Working port Fastening thread A/B	SAE J518 ⁵⁾ DIN 13	1 1/4 in M14 × 2; 19 deep	450 O
T₁	Drain port	DIN 3852 ⁷⁾	M26 × 1.5; 16 deep	3 X ⁶⁾
T₂	Drain port	DIN 3852 ⁷⁾	M26 × 1.5; 16 deep	3 O ⁶⁾
G	Synchronous control	DIN 3852 ⁷⁾	M14 × 1.5; 12 deep	450 X
G₂	2nd pressure setting (HD.E, EP.E)	DIN 3852 ⁷⁾	M14 × 1.5; 12 deep	100 X
U	Bearing flushing	DIN 3852 ⁷⁾	M22 × 1.5; 14 deep	3 X
X	Pilot signal (HP, HZ, HA1T/HA2T)	DIN 3852 ⁷⁾	M14 × 1.5; 12 deep	100 O
X	Pilot signal (HA1, HA2)	DIN 3852 ⁷⁾	M14 × 1.5; 12 deep	3 X
X₁, X₂	Pilot signal (DA1, DA4)	DIN 2353-CL	8B-ST	40 O
X₁	Pilot signal (DA2, DA3, DA5, DA6)	DIN 3852 ⁷⁾	M14 × 1.5; 12 deep	40 O
X₃	Pilot signal (DA2, DA3, DA5, DA6)	DIN 3852 ⁷⁾	M14 × 1.5; 12 deep	40 X
M₁	Stroking chamber measurement	DIN 3852 ⁷⁾	M14 × 1.5; 12 deep	450 X

1) To shaft collar

2) Port plate 1 – SAE working ports **A** and **B** at rear

3) For notes on tightening torques, see the instruction manual

4) Depending on the application, momentary pressure peaks can occur. Keep this in mind when selecting measuring devices and fittings.

5) Only dimensions according to SAE J518, metric fastening thread is a deviation from the standard

6) Depending on installation position, **T₁** or **T₂** must be connected (see also installation instructions on page 80).

7) The countersink can be deeper than as specified in the standard.

8) O = Must be connected (plugged when delivered)

X = Plugged (in normal operation)

▼ **Location of the working ports on the port plates (view Z)**

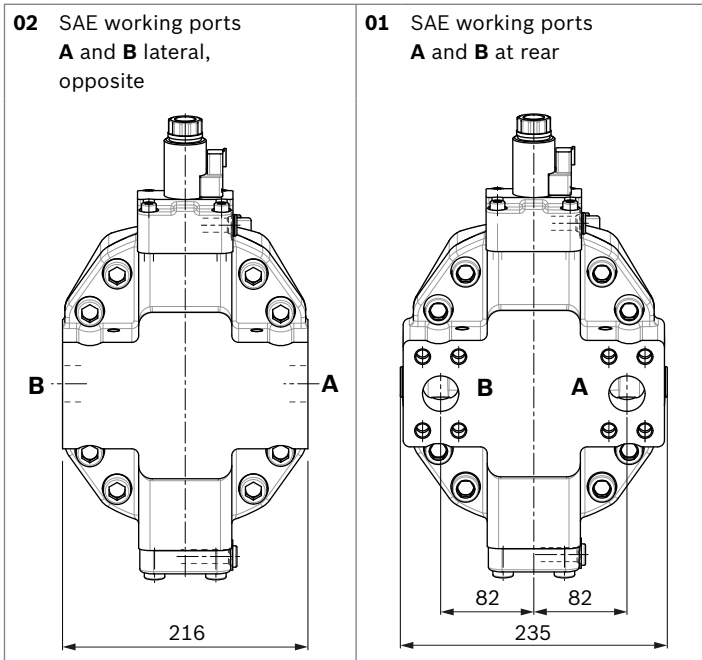

▼ **Splined shaft DIN 5480**

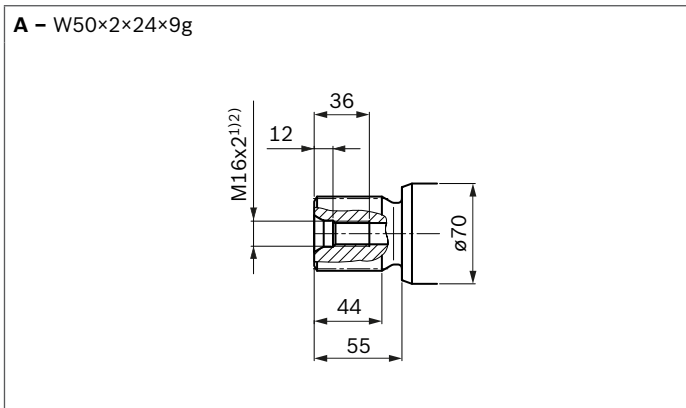

1) For notes on tightening torques, see the instruction manual
 2) Center bore according to DIN 332 (thread according to DIN 13)

▼ **EP.D** – Proportional control, electric,
 with pressure control fixed setting

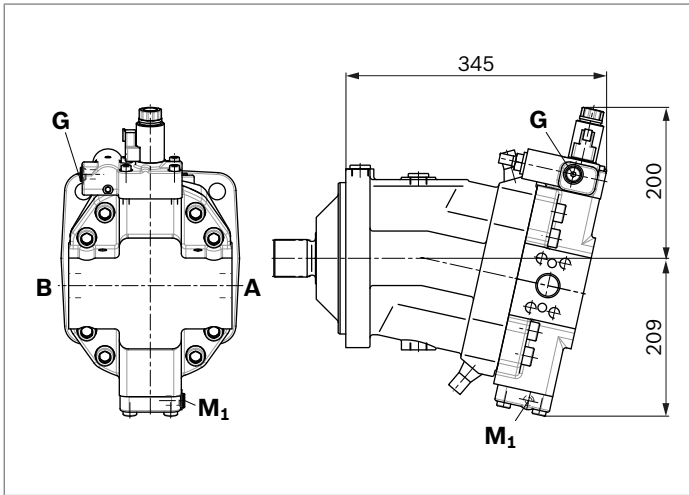

▼ **EP.E** – Proportional control, electric,
 with pressure control hydraulic override, two-point

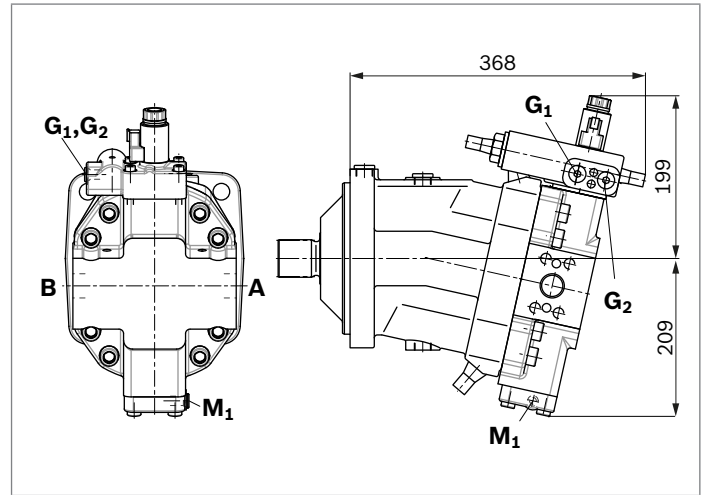

▼ **HD1, HD2** – Proportional control, hydraulic

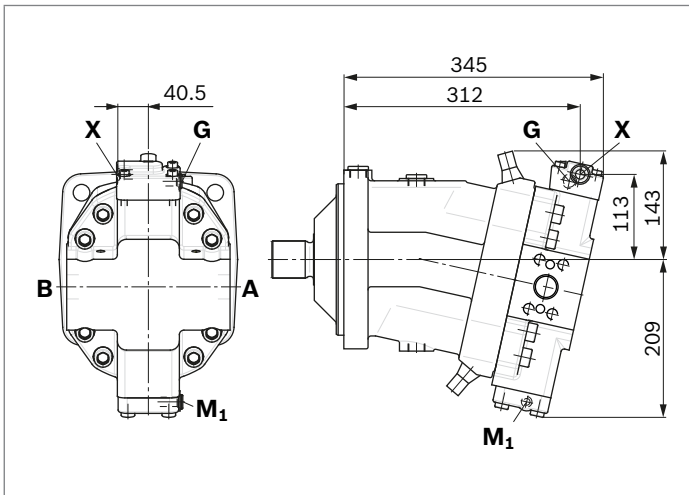

▼ **HD.D** – Proportional control, hydraulic,
 with pressure control fixed setting

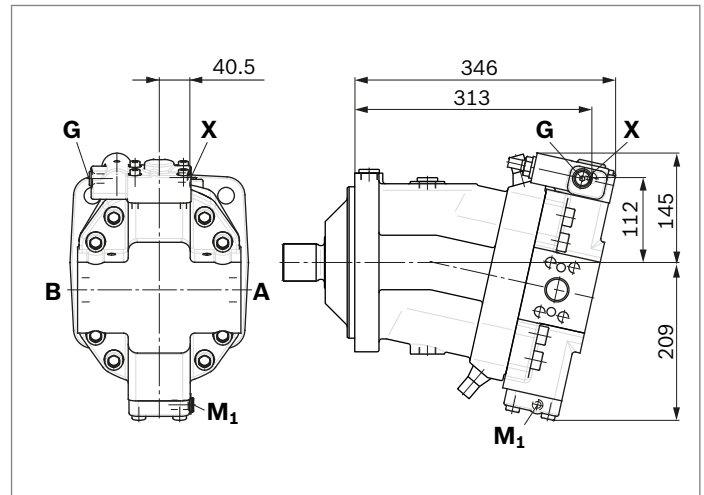

▼ **HD.E** – Proportional control, hydraulic,
 with pressure control hydraulic override, two-point

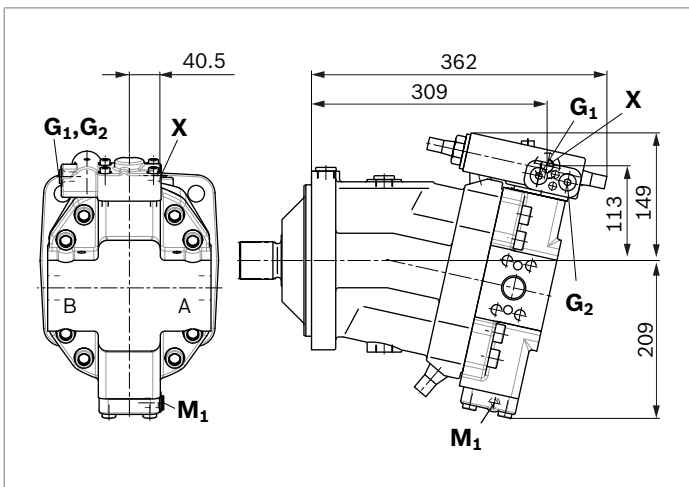

▼ **HZ1** – Two-point control, hydraulic

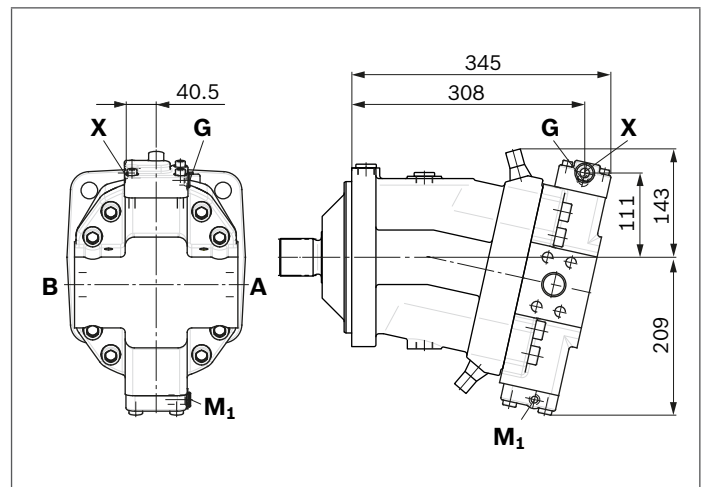

▼ **EZ1, EZ2** – Two-point control, electric

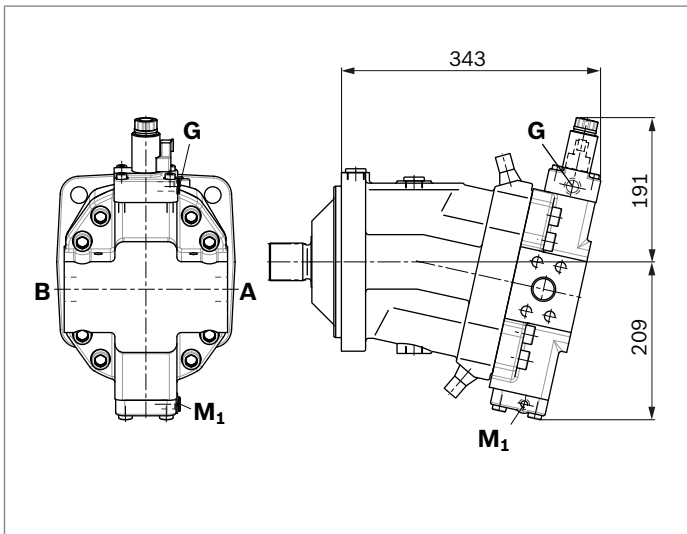

▼ **HA1, HA2 / HA1T, HA2T** – Automatic high-pressure related control, with override, hydraulic remote control, proportional

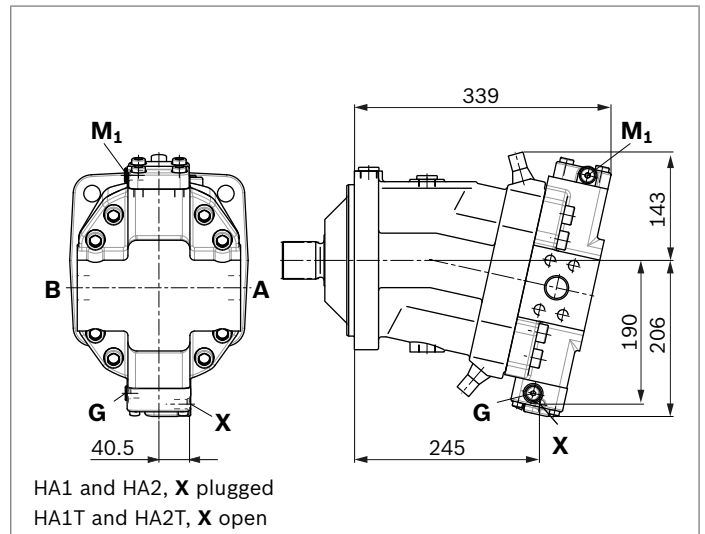

▼ **HA1U1, HA2U2** – Automatic high-pressure related control, with electric override, two-point

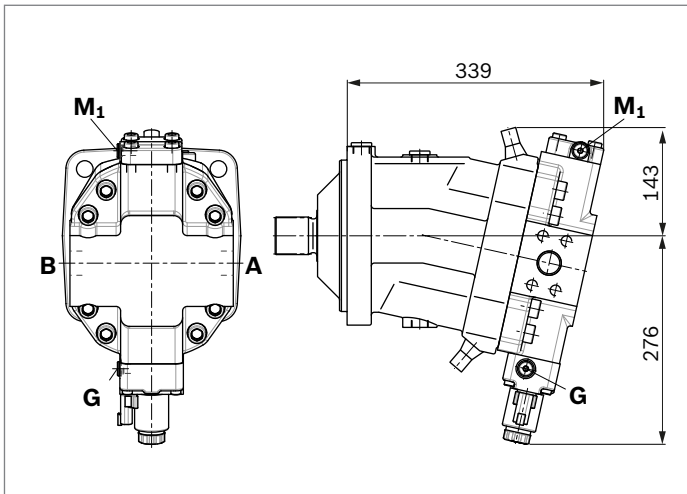

▼ **HA1R1, HA2R2** – Automatic high-pressure related control, with electric override and electric travel direction valve

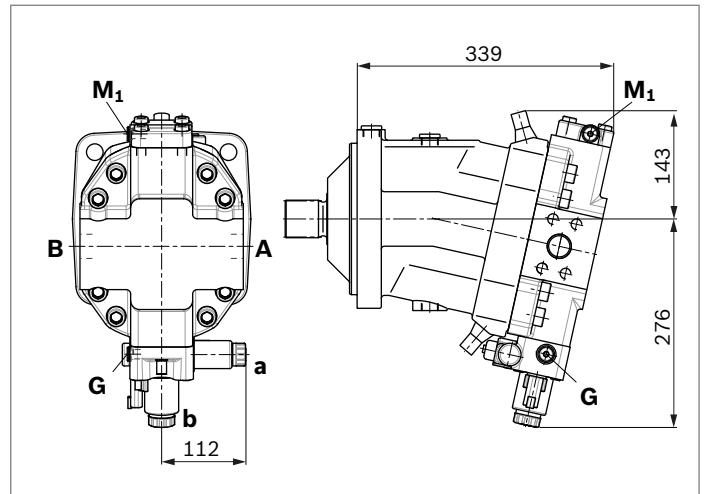

▼ **DA1, DA4** – Automatic speed related control, with hydraulic travel direction valve

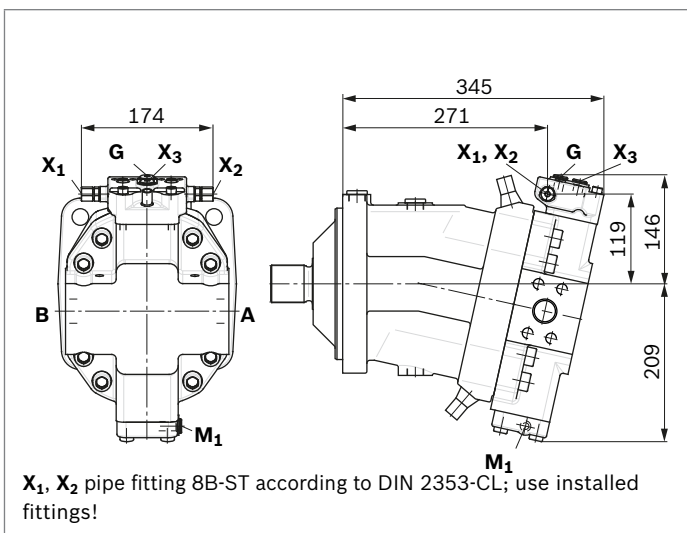

▼ **DA2, DA3, DA5, DA6** – Automatic speed related control, with electric travel direction valve and V_{g max}-circuit

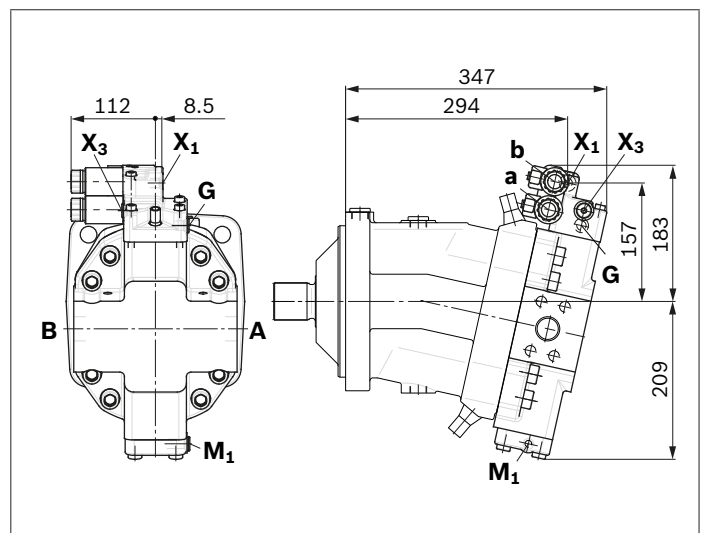

Dimensions, sizes 250

HD1, HD2 – Proportional control, hydraulic

HZ – Two-point control, hydraulic

Port plate 2 – SAE working ports **A** and **B** lateral, opposing

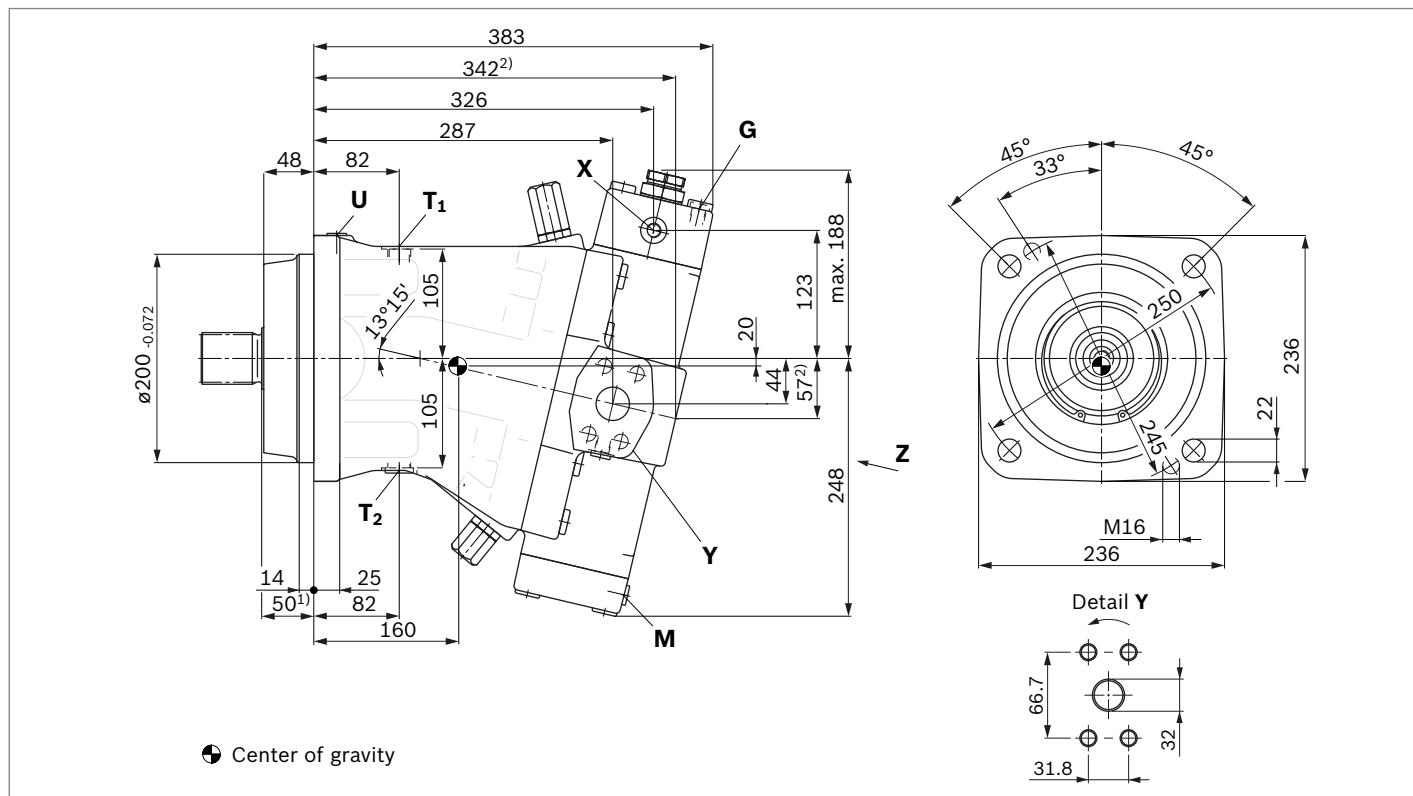

Ports	Standard	Size ³⁾	p_{max} [bar] ⁴⁾	State ⁸⁾
A, B	Working port Fastening thread A/B	SAE J518 ⁵⁾ DIN 13	1 1/4 in M14 × 2; 19 deep	400 O
A₁, B₁	Additional working port for plate 15 fastening thread A ₁ /B ₁	SAE J518 ⁵⁾ DIN 13	1 1/4 in M14 × 2; 19 deep	400 O
T₁	Drain port	DIN 3852 ⁷⁾	M22 × 1.5; 14 deep	3 X ⁶⁾
T₂	Drain port	DIN 3852 ⁷⁾	M22 × 1.5; 14 deep	3 O ⁶⁾
G	Synchronous control	DIN 3852 ⁷⁾	M14 × 1.5; 12 deep	400 X
G₂	2nd pressure setting (HD.D, EP.D)	DIN 3852 ⁷⁾	M14 × 1.5; 12 deep	400 X
P	Pilot oil supply (EP)	DIN 3852 ⁷⁾	M14 × 1.5; 12 deep	100 O
U	Bearing flushing	DIN 3852 ⁷⁾	M14 × 1.5; 12 deep	3 X
X	Pilot signal (HD, HZ, HA1T/HA2T)	DIN 3852 ⁷⁾	M14 × 1.5; 12 deep	100 O
X	Pilot signal (HA1, HA2)	DIN 3852 ⁷⁾	M14 × 1.5; 12 deep	3 X
X₁, X₂	Pilot signal (DA)	DIN 2353-CL	8B-ST	40 O
X₃	Pilot signal (HD.G, EP.G)	DIN 3852 ⁷⁾	M14 × 1.5; 12 deep	400 O
M	Stroking chamber measurement	DIN 3852 ⁷⁾	M14 × 1.5; 12 deep	400 X
M_A, M_B	Pressure measurement A/B	DIN 3852 ⁷⁾	M14 × 1.5; 12 deep	400 X
M_{St}	Pilot pressure measurement	DIN 3852 ⁷⁾	M14 × 1.5; 12 deep	400 X

1) To shaft collar

2) Port plate 1/15 – SAE working ports **A** and **B** at rear

3) For notes on tightening torques, see the instruction manual

4) Depending on the application, momentary pressure peaks can occur. Keep this in mind when selecting measuring devices and fittings.

5) Only dimensions according to SAE J518, metric fastening thread is a deviation from the standard

6) Depending on installation position, **T₁** or **T₂** must be connected (see also installation instructions on page 80).

7) The countersink can be deeper than as specified in the standard.

8) O = Must be connected (plugged when delivered)

X = Plugged (in normal operation)

▼ Location of the working ports on the port plates (view Z)

02 SAE working ports
A and **B** lateral,
 opposite

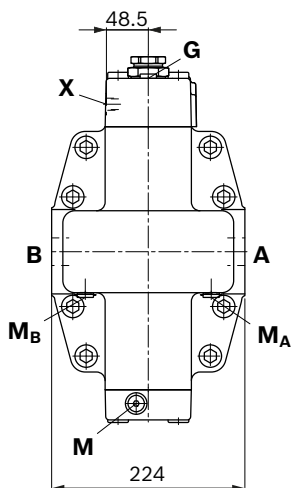

01 SAE working ports
A and **B** at rear

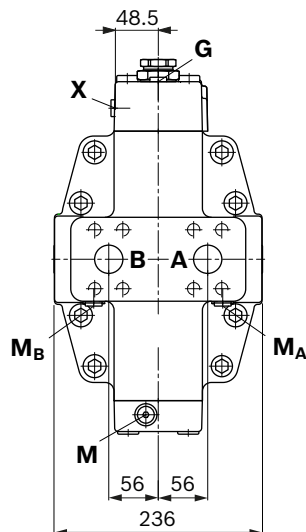

15 SAE working ports
A and **B** lateral,
 opposite,
A₁ and **B₁** at rear

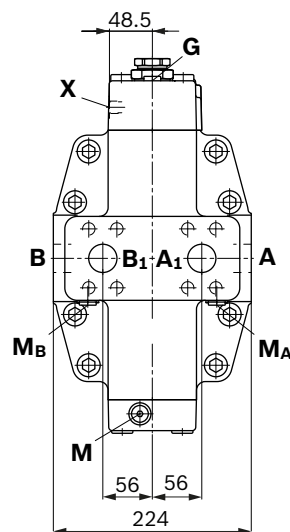

▼ Splined shaft DIN 5480

Z - W50×2×24×9g

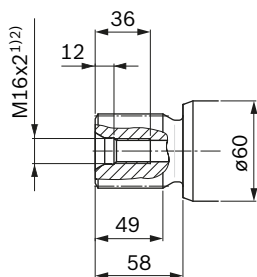

▼ Cyl. Keyed shaft, DIN 6885

P - AS14×9×80

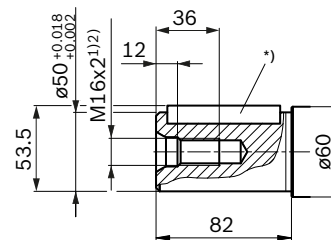

^{*)} Key width 14

1) For notes on tightening torques, see the instruction manual
 2) Center bore according to DIN 332 (thread according to DIN 13)

▼ **EP1, EP2** – Proportional control, electric

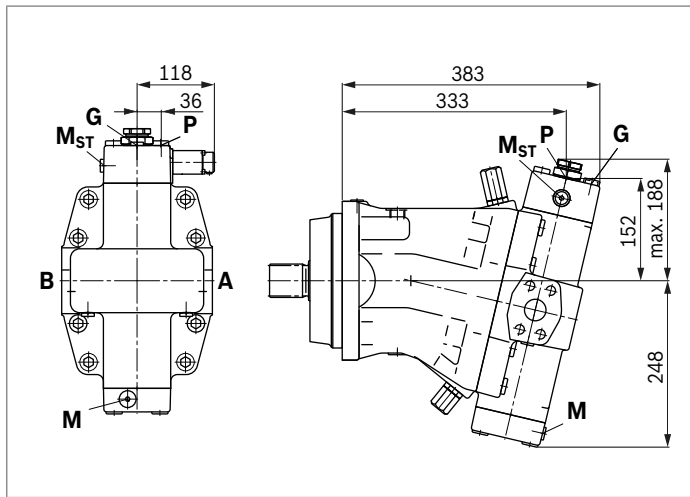

▼ **EP.D, EP.G** – Proportional control electric, with pressure control fixed setting; remote controlled (EP.G)

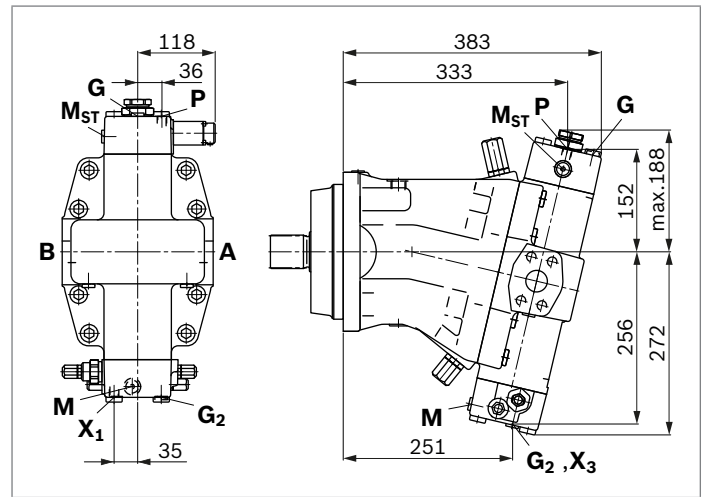

▼ **HD.D, HD.G** – Proportional control hydraulic with pressure control fixed setting; remote controlled (HD.G)

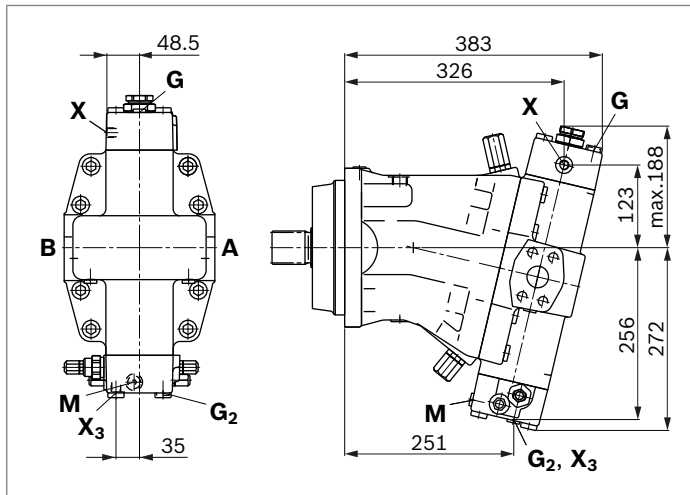

▼ **EZ1, EZ2** – Two-point control, electric

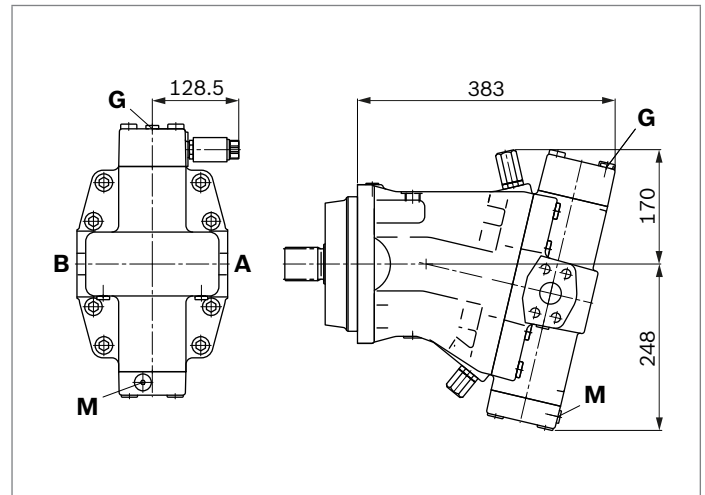

▼ **HA1, HA2 / HA1T, HA2T** – Automatic high-pressure related control, with override hydraulic remote control, proportional

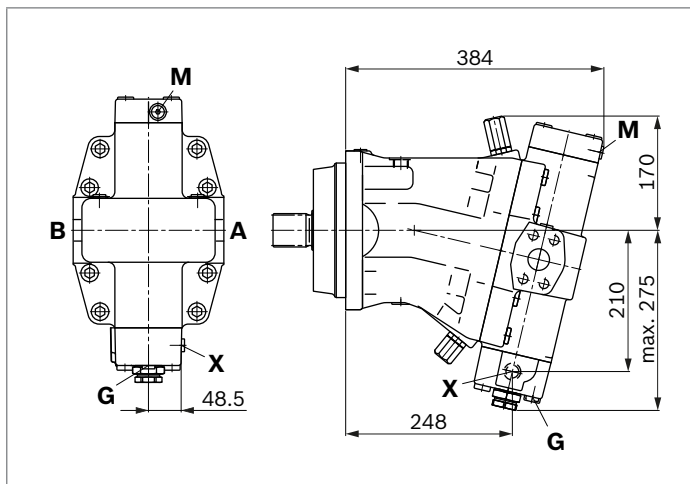

▼ **DA** – Automatic speed related control, with hydraulic travel direction valve

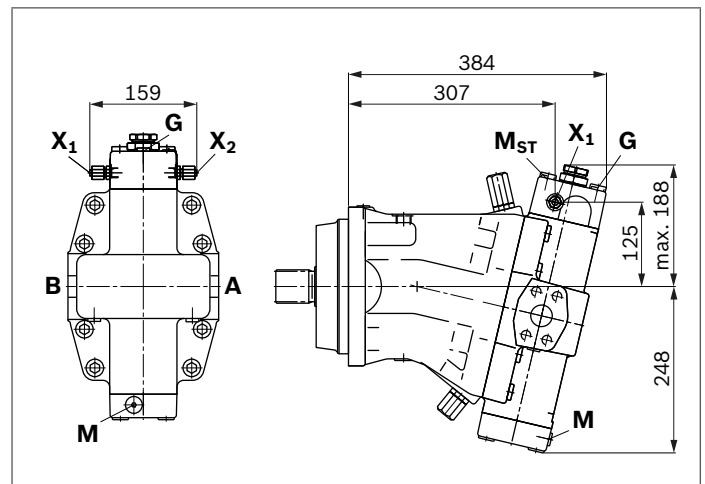

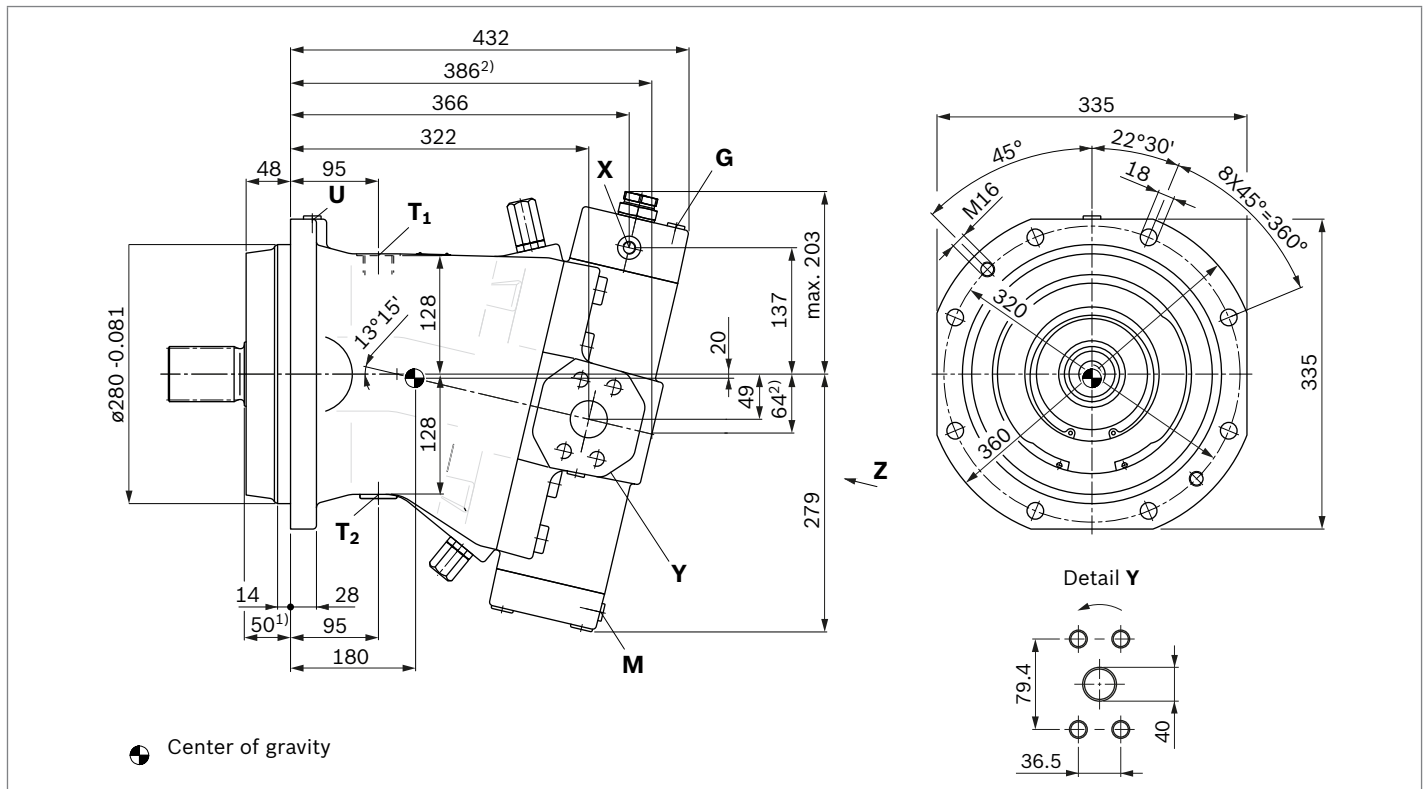
Dimensions, sizes 355**HD1, HD2 – Proportional control, hydraulic****HZ – Two-point control, hydraulic**Port plate 2 – SAE working ports **A** and **B** lateral, opposite

Ports		Standard	Size ³⁾	p_{max} [bar] ⁴⁾	State ⁵⁾
A, B	Working port Fastening thread A/B	SAE J518 ⁵⁾ DIN 13	1 1/2 in M16 × 2; 24 deep	400	O
A₁, B₁	Additional working port for plate 15 fastening thread A ₁ /B ₁	SAE J518 ⁵⁾ DIN 13	1 1/2 in M16 × 2; 24 deep	400	O
T₁	Drain port	DIN 3852 ⁷⁾	M33 × 2; 18 deep	3	X ⁶⁾
T₂	Drain port	DIN 3852 ⁷⁾	M33 × 2; 18 deep	3	O ⁶⁾
G	Synchronous control	DIN 3852 ⁷⁾	M14 × 1.5; 12 deep	400	X
G₂	2nd pressure setting (HD.D, EP.D)	DIN 3852 ⁷⁾	M14 × 1.5; 12 deep	400	X
P	Pilot oil supply (EP)	DIN 3852 ⁷⁾	M14 × 1.5; 12 deep	100	O
U	Bearing flushing	DIN 3852 ⁷⁾	M14 × 1.5; 12 deep	3	X
X	Pilot signal (HD, HZ, HA1T/HA2T)	DIN 3852 ⁷⁾	M14 × 1.5; 12 deep	100	O
X	Pilot signal (HA1, HA2)	DIN 3852 ⁷⁾	M14 × 1.5; 12 deep	3	X
X₁, X₂	Pilot signal (DA)	DIN 2353-CL	8B-ST	40	O
X₃	Pilot signal (HD.G, EP.G)	DIN 3852 ⁷⁾	M14 × 1.5; 12 deep	400	O
M	Stroking chamber measurement	DIN 3852 ⁷⁾	M14 × 1.5; 12 deep	400	X
M_A, M_B	Pressure measurement A/B	DIN 3852 ⁷⁾	M14 × 1.5; 12 deep	400	X
M_{ST}	Pilot pressure measurement	DIN 3852 ⁷⁾	M14 × 1.5; 12 deep	400	X

1) To shaft collar

2) Port plate 1/15 – SAE working ports **A** and **B**

3) For notes on tightening torques, see the instruction manual

4) Depending on the application, momentary pressure peaks can occur.
Keep this in mind when selecting measuring devices and fittings.

5) Only dimensions according to SAE J518, metric fastening thread is a deviation from the standard

6) Depending on installation position, **T₁** or **T₂** must be connected (see also installation instructions on page 80).

7) The countersink can be deeper than as specified in the standard.

8) O = Must be connected (plugged when delivered)

X = Plugged (in normal operation)

▼ **Location of the working ports on the port plates (view Z)**

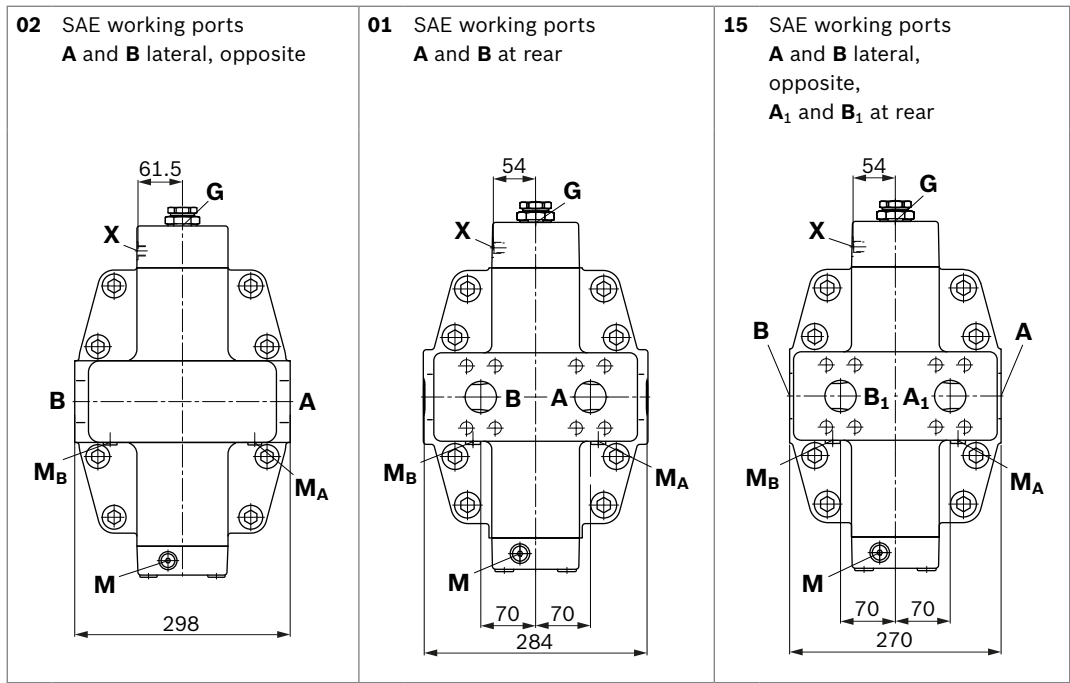

▼ **Splined shaft DIN 5480**

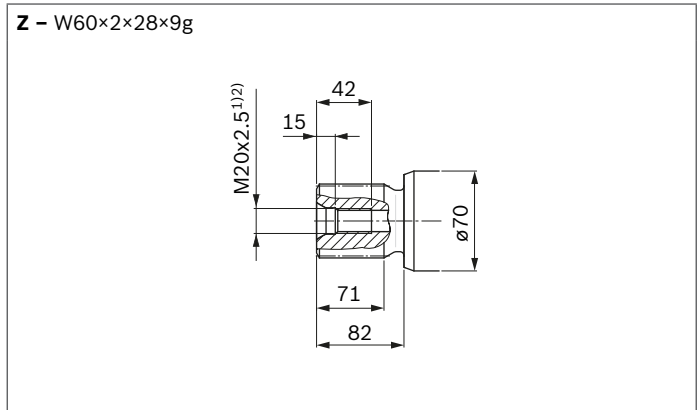

▼ **Cyl. Keyed shaft, DIN 6885**

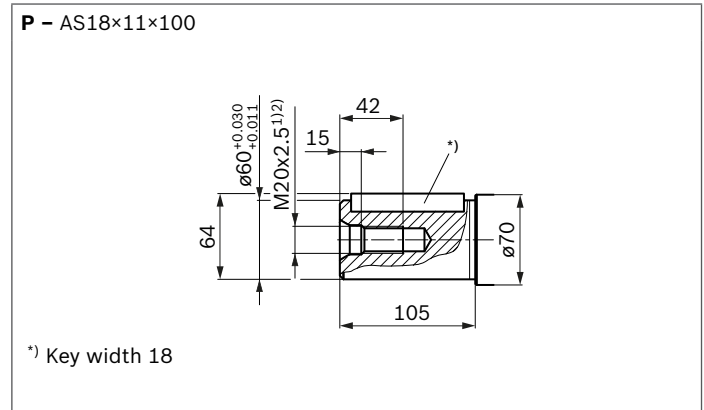

1) For notes on tightening torques, see the instruction manual
2) Center bore according to DIN 332 (thread according to DIN 13)

▼ Location of the working ports on the port plates (view Z)

02 SAE working ports
A and **B** lateral,
 opposite

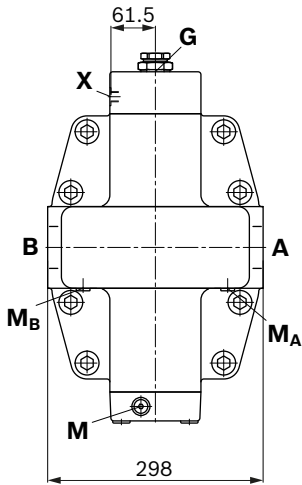

01 SAE working ports
A and **B** at rear

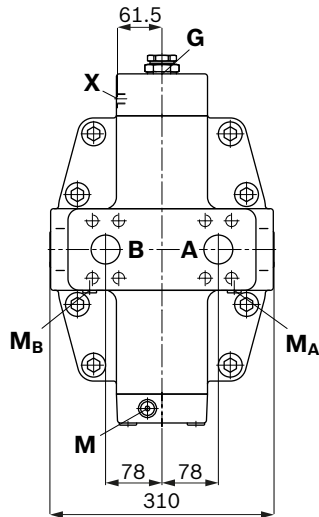

15 SAE working ports
A and **B** lateral,
 opposite,
A₁ and **B₁** at rear

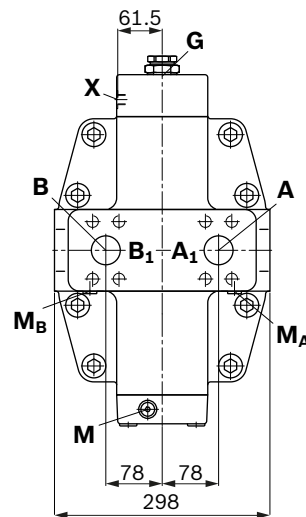

▼ Splined shaft DIN 5480

Z – W70×3×22×9g

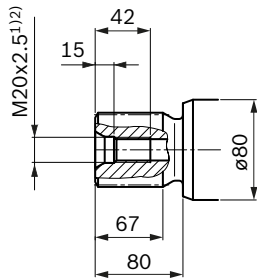

▼ Cyl. Keyed shaft, DIN 6885

P – AS20×12×100

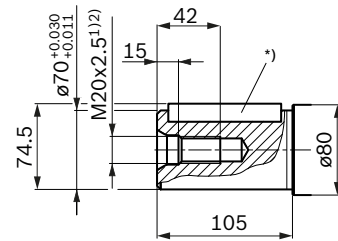

^{*)} Key width 20

1) For notes on tightening torques, see the instruction manual
 2) Center bore according to DIN 332 (thread according to DIN 13)

▼ **EP1, EP2** – Proportional control, electric

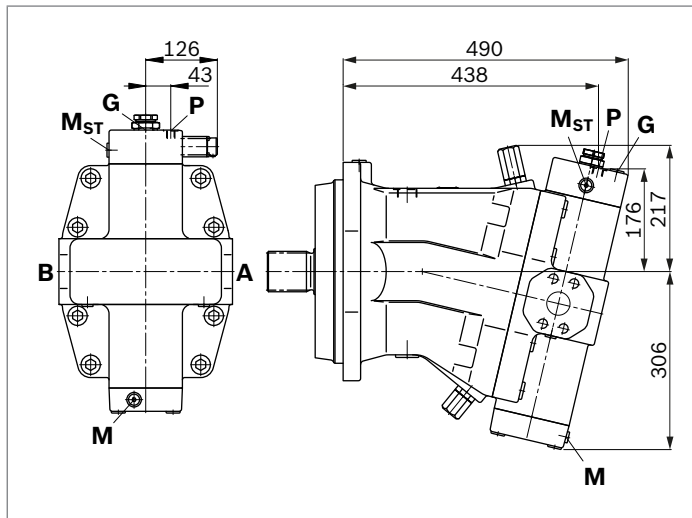

▼ **EP.D, EP.G** – Proportional control electric, with pressure control fixed setting; remote controlled (EP.G)

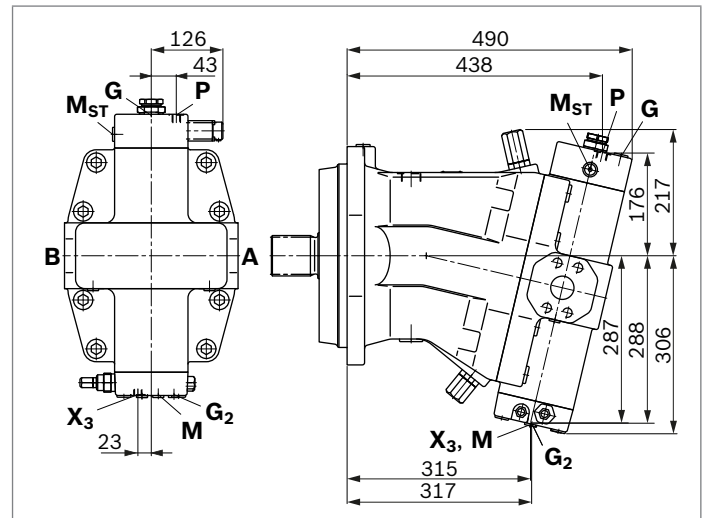

▼ **HD.D, HD.G** – Proportional control hydraulic with pressure control fixed setting; remote controlled (HD.G)

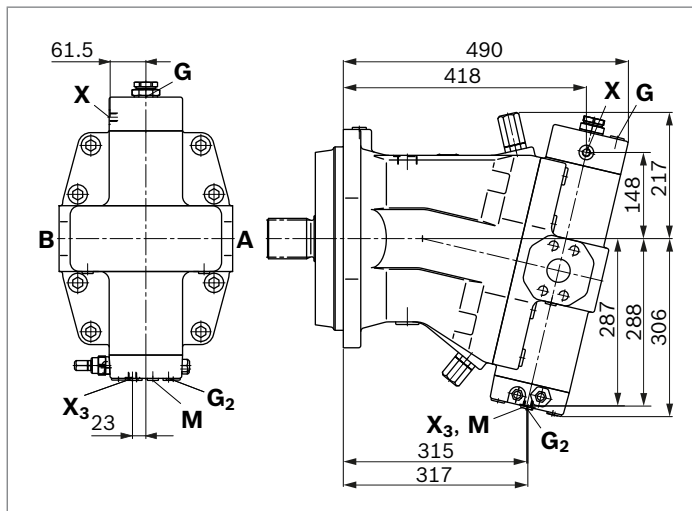

▼ **EZ1, EZ2** – Two-point control, electric

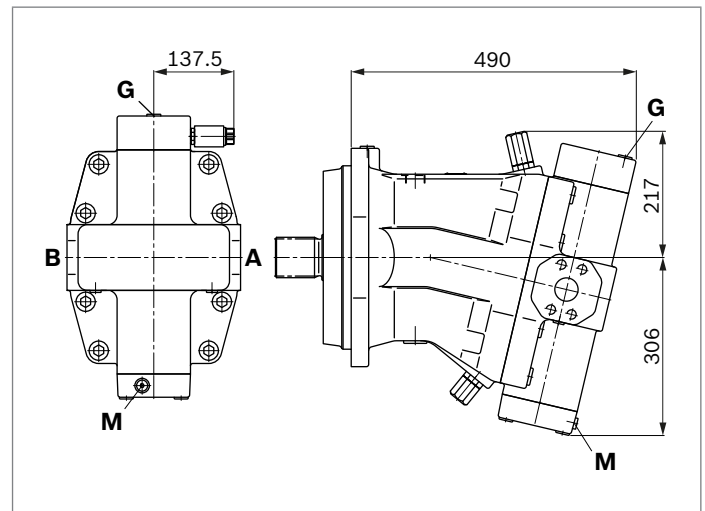

▼ **HA1, HA2 / HA1T, HA2T** – Automatic high-pressure related control, with override, hydraulic remote control, proportional

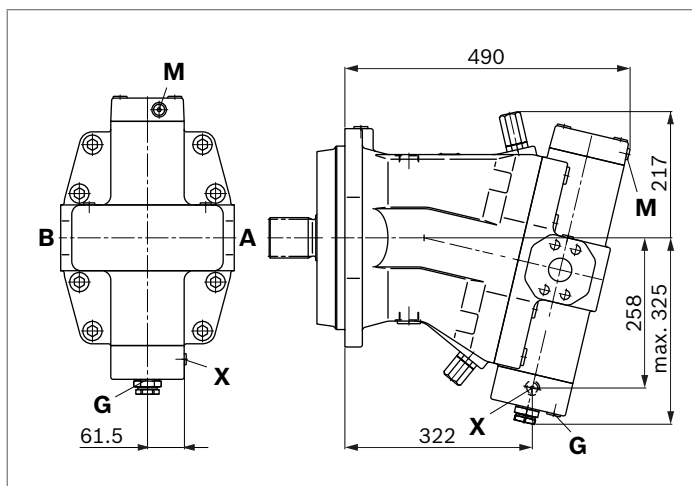

▼ **DA** – Automatic speed related control, with hydraulic travel direction valve

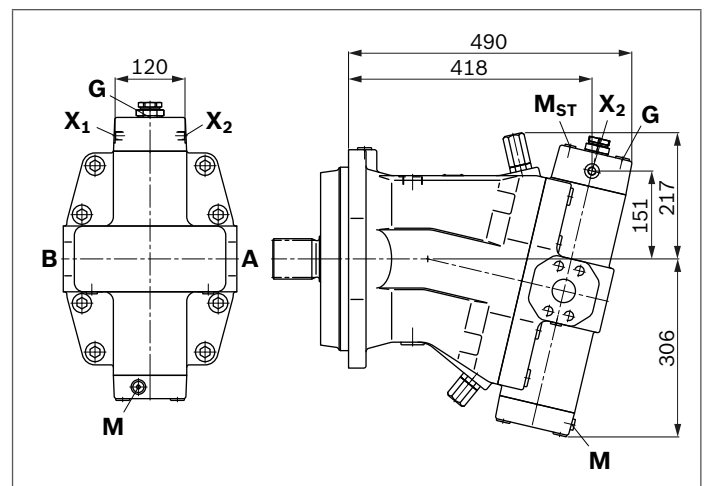

Dimensions, sizes 1000

HD1, HD2 – Proportional control, hydraulic

HZ – Two-point control, hydraulic

Port plate 2 – SAE working ports **A** and **B** lateral, opposite

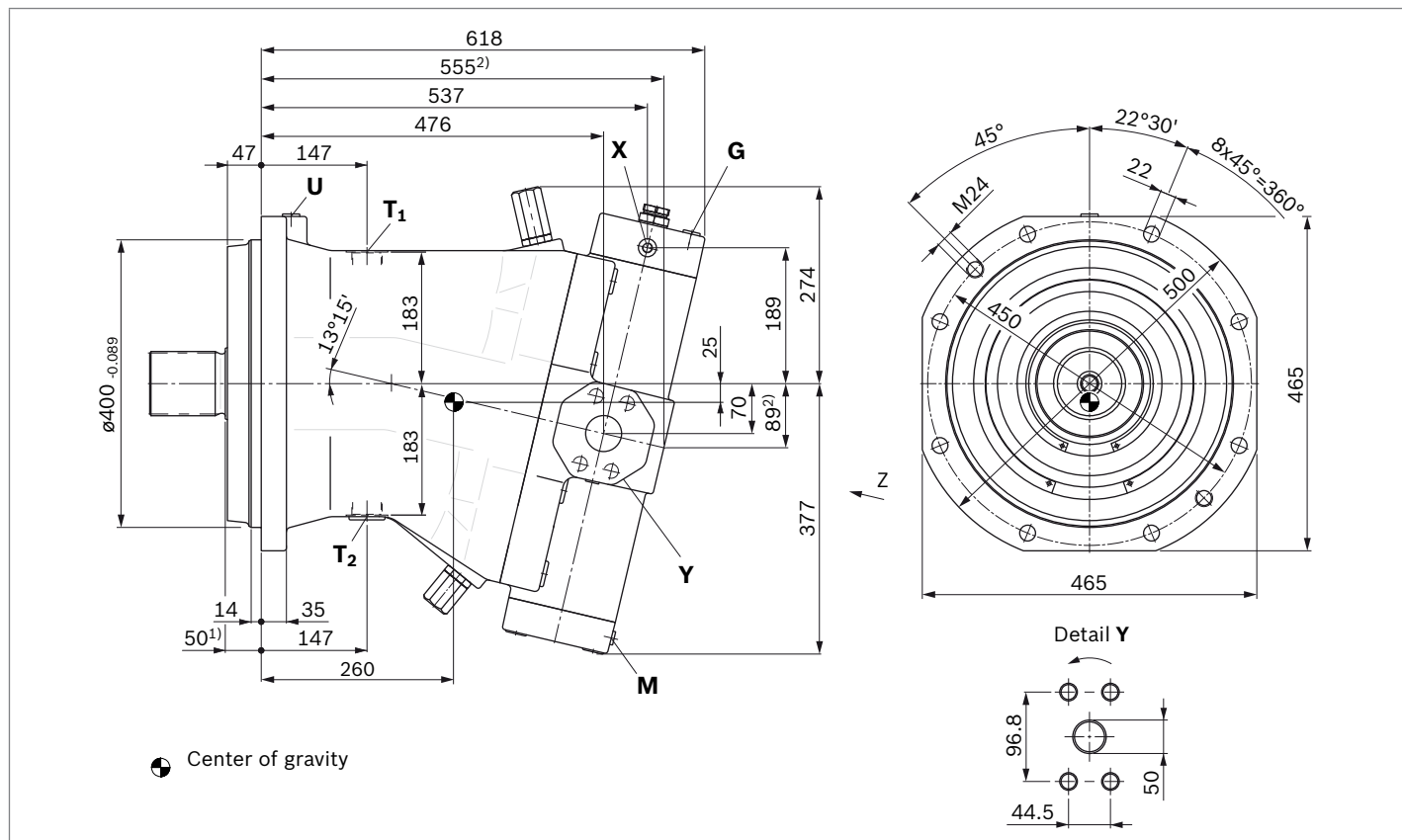

Ports	Standard	Size ³⁾	p_{max} [bar] ⁴⁾	State ⁵⁾	
A, B	Working port	SAE J518 ⁵⁾	2 in	400	O
	Fastening thread A/B	DIN 13	M20 × 2.5; 24 deep		
A₁, B₁	Additional working port for plate 15	SAE J518 ⁵⁾	2 in	400	O
	fastening thread A ₁ /B ₁	DIN 13	M20 × 2.5; 24 deep		
T₁	Drain port	DIN 3852 ⁷⁾	M42 × 2; 20 deep	3	X ⁶⁾
T₂	Drain port	DIN 3852 ⁷⁾	M42 × 2; 20 deep	3	O ⁶⁾
G	Synchronous control	DIN 3852 ⁷⁾	M18 × 1.5; 12 deep	400	X
G₂	2nd pressure setting (HD.E, EP.E)	DIN 3852 ⁷⁾	M18 × 1.5; 12 deep	400	X
P	Pilot oil supply (EP)	DIN 3852 ⁷⁾	M14 × 1.5; 12 deep	100	O
U	Bearing flushing	DIN 3852 ⁷⁾	M18 × 1.5; 12 deep	3	X
X	Pilot signal (HD, HZ, HA1T/HA2T)	DIN 3852 ⁷⁾	M14 × 1.5; 12 deep	100	O
X	Pilot signal (HA1, HA2)	DIN 3852 ⁷⁾	M14 × 1.5; 12 deep	3	X
X₃	Pilot signal (HD.G, EP.G)	DIN 3852 ⁷⁾	M14 × 1.5; 12 deep	400	O
M	Stroking chamber measurement	DIN 3852 ⁷⁾	M14 × 1.5; 12 deep	400	X
M_A, M_B	Pressure measurement A/B	DIN 3852 ⁷⁾	M14 × 1.5; 12 deep	400	X
M_{St}	Pilot pressure measurement	DIN 3852 ⁷⁾	M14 × 1.5; 12 deep	400	X

- 1) To shaft collar
- 2) Port plate 1/15 – SAE working ports **A** and **B** at rear
- 3) For notes on tightening torques, see the instruction manual
- 4) Depending on the application, momentary pressure peaks can occur. Keep this in mind when selecting measuring devices and fittings.
- 5) Only dimensions according to SAE J518, metric fastening thread is a deviation from the standard
- 6) Depending on installation position, **T₁** or **T₂** must be connected (see also installation instructions on page 80).
- 7) The countersink can be deeper than as specified in the standard.
- 8) O = Must be connected (plugged when delivered)
 X = Plugged (in normal operation)

▼ **Location of the working ports on the port plates (view Z)**

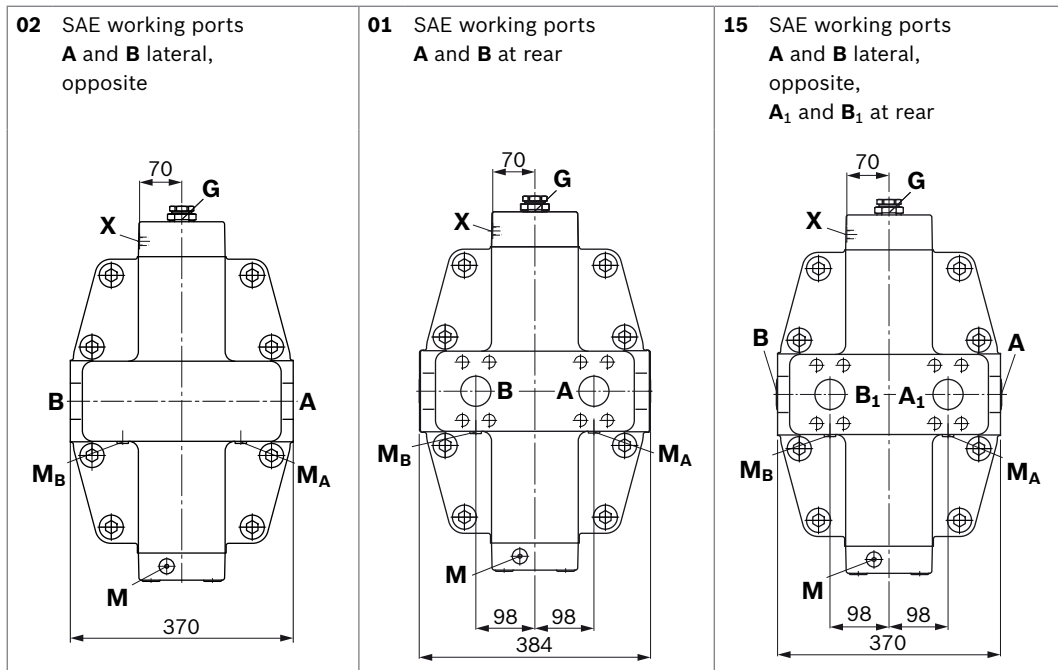

▼ **Splined shaft DIN 5480**

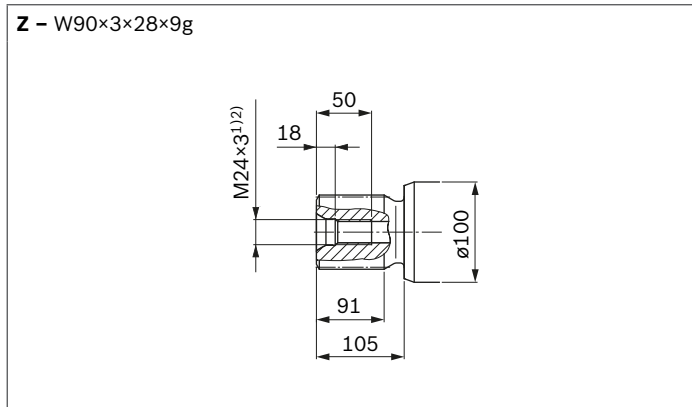

▼ **Cyl. Keyed shaft, DIN 6885**

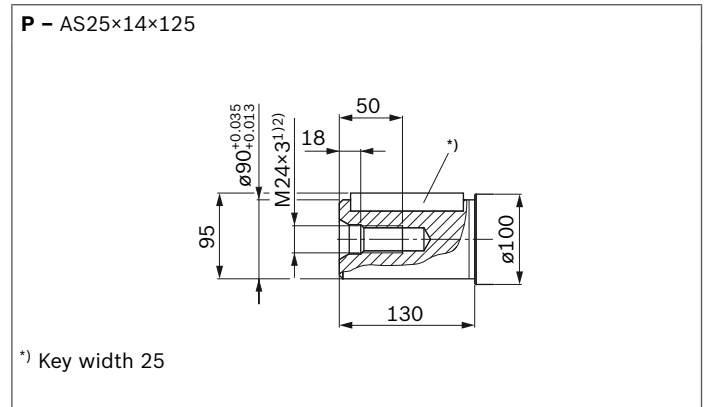

1) For notes on tightening torques, see the instruction manual
2) Center bore according to DIN 332 (thread according to DIN 13)

▼ **EP1, EP2** – Proportional control, electric

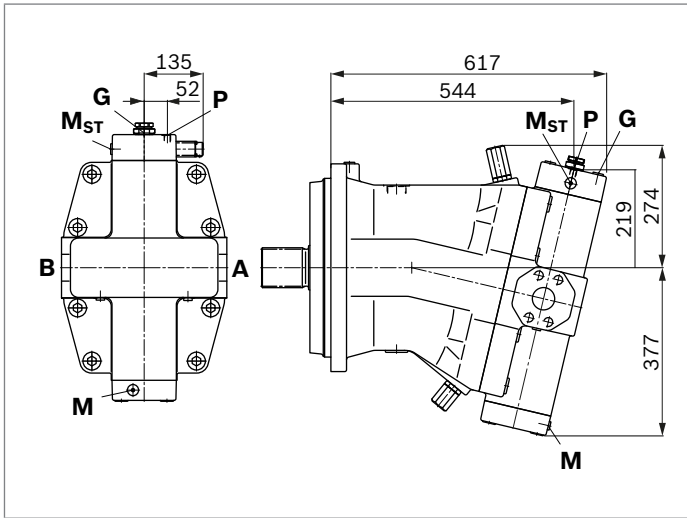

▼ **EP.D, EP.G** – Proportional control electric, with pressure control fixed setting; remote controlled (EP.G)

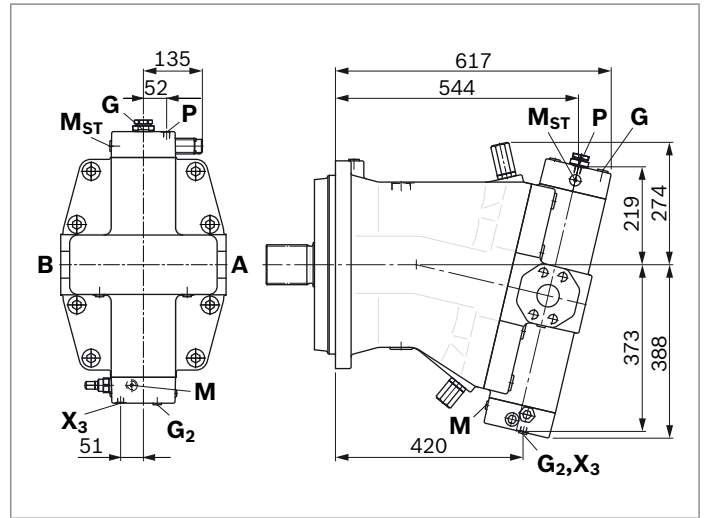

▼ **HD.D, HD.G** – Proportional control hydraulic with pressure control fixed setting; remote controlled (HD.G)

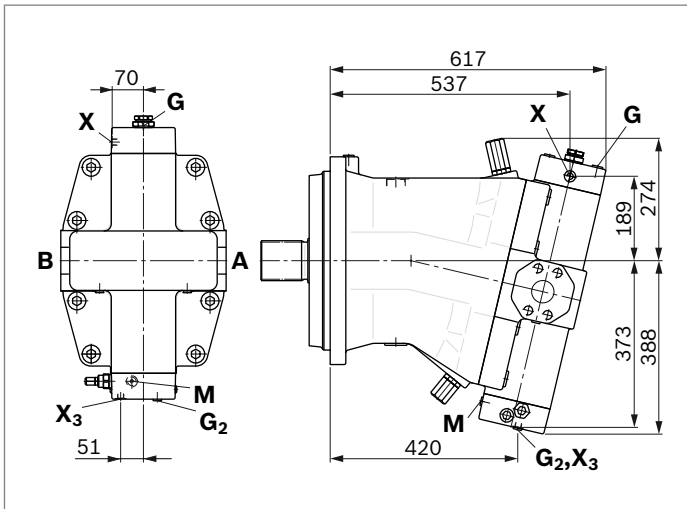

▼ **EZ1, EZ2** – Two-point control, electric

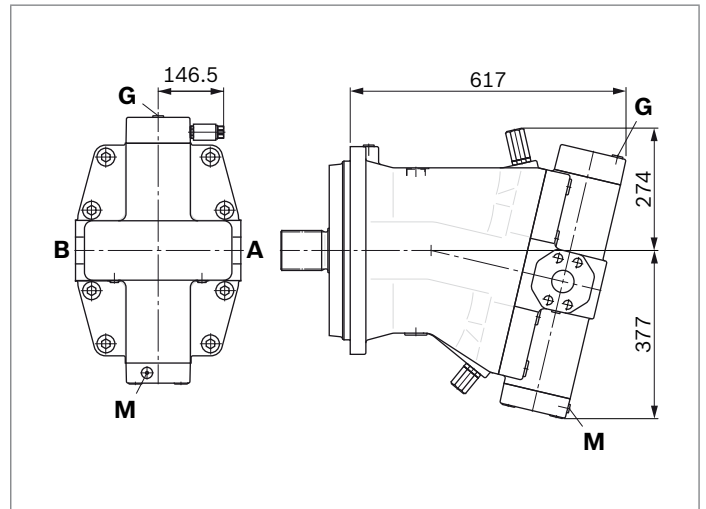

▼ **HA1, HA2 / HA1T, HA2T** – Automatic high-pressure related control, with override hydraulic remote control, proportional

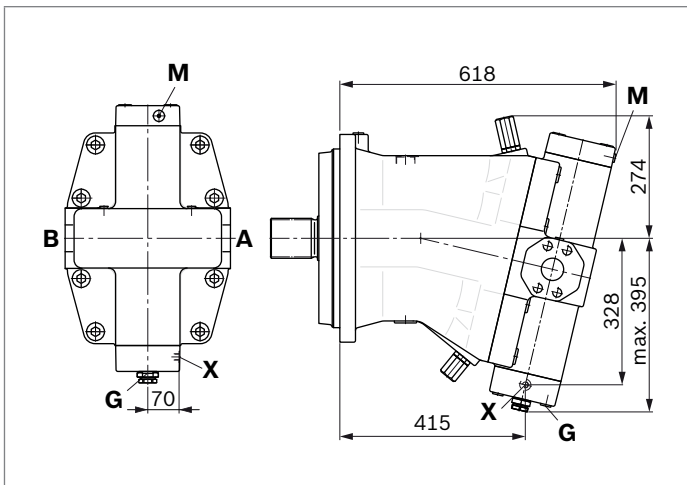

Connector for solenoids

DEUTSCH DT04-2P-EP04

Sizes 28 to 200

Molded connector, 2-pin, without bidirectional suppressor diode

The following type of protection ensues with an installed mating connector:

- ▶ IP67 (DIN/EN 60529) and
- ▶ IP69K (DIN 40050-9)

▼ Switching symbol

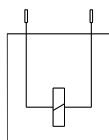

▼ Mating connector DEUTSCH DT06-2S-EP04

Consisting of	DT designation
1 housing	DT06-2S-EP04
1 wedge	W2S
2 sockets	0462-201-16141

The mating connector is not included in the scope of delivery. This can be supplied by Bosch Rexroth on request (material number R902601804).

Notice

- ▶ If necessary, you can change the position of the connector by turning the solenoid.
- ▶ The procedure is defined in the instruction manual.

HIRSCHMANN DIN EN 175 301-803-A/ISO 4400

Sizes 250 to 1000

Without bidirectional suppressor diode

Type of protection:

- ▶ IP65 (DIN/EN 60529)

The seal ring in the cable fitting is suitable for lines of diameter 4.5 mm to 10 mm.

The mating connector is included in the scope of delivery.

Flushing and boost-pressure valve

The flushing and boost-pressure valve is used to remove heat from the hydraulic circuit.

In a closed circuit, it is used for flushing the case and safeguarding the minimum boost pressure.

Hydraulic fluid is directed from the respective low pressure side into the motor housing. This is then fed into the reservoir, together with the leakage. In the closed circuit, the removed hydraulic fluid must be replaced by cooled hydraulic fluid supplied by the boost pump.

The valve is mounted on the port plate or integrated (depending on the control type and size).

Cracking pressure of pressure retaining valve

(observe when setting the primary valve)

- ▶ sizes 28 to 1000, fixed setting 16 bar

Switching pressure of flushing spool Δp

- ▶ sizes 28 to 200, 8 ± 1 bar
- ▶ sizes 250 to 1000, 17.5 ± 1.5 bar

Flushing flow q_v

Orifices can be used to adjust the flushing flows as required. The following parameters are based on:

$$\Delta p_{ND} = p_{ND} - p_G = 25 \text{ bar and } v = 10 \text{ mm}^2/\text{s}$$

(p_{ND} = low pressure, p_G = case pressure)

Flushing valve for sizes 28 to 200

Material number of orifice	\varnothing [mm]	q_v [l/min]
R909651766	1.2	3.5
R909419695	1.4	5
R909419696	1.8	8
R909419697	2.0	10
R909444361	2.4	14

Flushing valve for sizes 250 to 1000

Material number of orifice	\varnothing [mm]	q_v [l/min]
R909419697	2.0	10
R910928643	2.8	16

▼ Circuit diagram EP, sizes 28 to 200

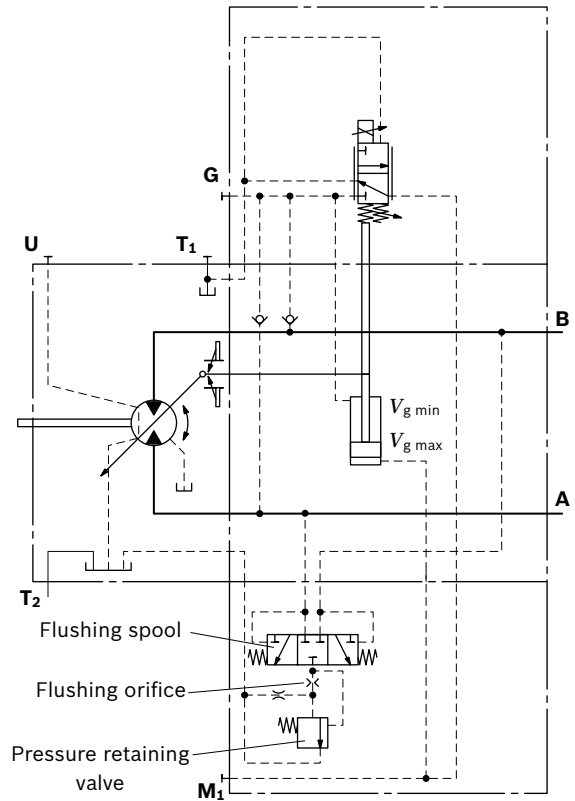

▼ Circuit diagram EP, sizes 250 to 1000

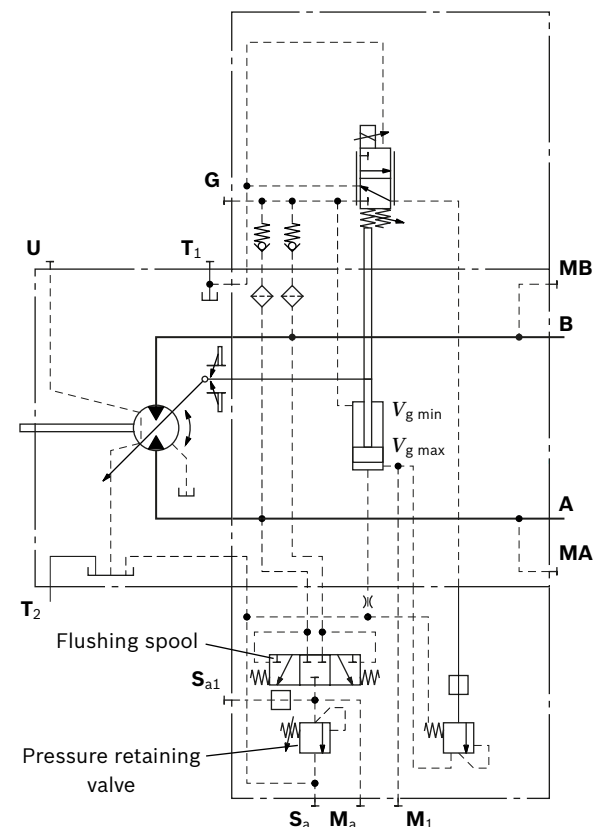

▼ **Dimensions, sizes 28 to 200**

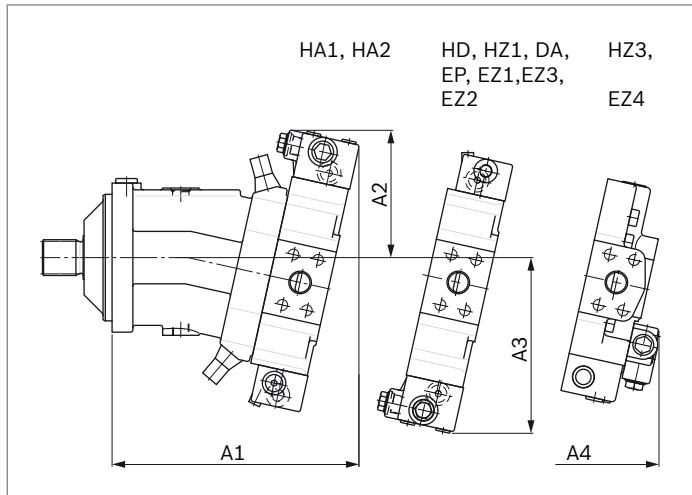

NG	A1	A2	A3	A4
28	214	125	161	-
55	245	137	183	236
80	273	142	193	254
107	287	143	202	269
140	321	154	218	-
160	328	154	220	-
200	345	160	231	-

▼ **Dimensions, sizes 250 to 1000**

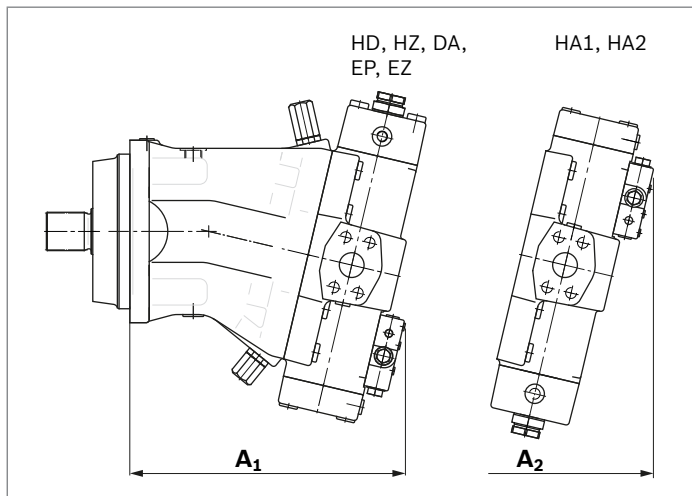

NG	A1	A2
250	357	402
355	397	446
500	440	504
1000	552	629

BVD and BVE counterbalance valve

Function

Counterbalance valves for drives and winches should reduce the danger of overspeed and cavitation in open circuits of axial piston motors. Cavitation occurs if, during braking, when going downhill or during the load-lowering process, the motor speed is greater than it should be for the given inlet flow and thus the supply pressure collapses. If the supply pressure falls below the level specified for the relevant counterbalance valve, the counterbalance valve spool moves into the closed position. The cross-sectional area of the counterbalance valve return duct is then reduced, creating a bottleneck in the return flow of the hydraulic fluid. The pressure increases and brakes the motor until the rotational speed of the motor reaches the specified value for the given inlet flow.

Notice

- ▶ BVD available for sizes 55 to 200 and BVE available for sizes 107 to 160.
- ▶ The counterbalance valve must be ordered additionally. We recommend ordering the counterbalance valve and the motor as a set.
 Order example: A6VM80HA1T/63W-VAB38800A + BVD20F27S/41B-V03K16D0400S12

- ▶ For safety reasons, controls with beginning of control at $V_{g \min}$ (e.g. HA) are not permissible for winch drives!
- ▶ Counterbalance valves must be optimized during prototype commissioning to prevent unacceptable operating conditions and compliance with the specification must be verified.
- ▶ The counterbalance valve does not replace the mechanical service brake and holding brake.
- ▶ Observe the detailed notes on the counterbalance valve in data sheet 95522 – BVD and in data sheet 95525 – BVE!
- ▶ For the design of the brake release valve, we require the following data for the mechanical holding brake:
 - the cracking pressure
 - the volume of the counterbalance spool between minimum travel (brake closed) and maximum stroke (brake released with 21 bar)
 - the required closing time for a warm device (oil viscosity approx. 15 mm²/s)

Permissible inlet flow or pressure when using pressure relief valve and BVD/BVE

Motor NG	Without valve		Limited values when using pressure relief valves and BVD/BVE							
	p_{nom}/p_{max} [bar]	$q_V \max$ [l/min]	DBV ¹⁾ NG	p_{nom}/p_{max} [bar]	q_V [l/min]	Code	BVD ^{2)/BVE³⁾ NG}	p_{nom}/p_{max} [bar]	q_V [l/min]	Code
55	400 /450	244	22	350 /420	240	380	20 (BVD)	350 /420	220	388
80		312								
107		380	380		380	388				
107		380								
140		455								
160		496								
200		580	On request							
250	350 /400	675	On request							
355 to 1000	not available									

Mounting of the counterbalance valve

When delivered, the counterbalance valve is mounted to the motor with two tacking screws (transport lock). The tacking screws may not be removed while mounting the working lines! If the counterbalance valve and motor are delivered separately, the counterbalance valve must first be mounted to the motor port plate using the provided tacking screws.

The counterbalance valve is finally mounted to the motor by fitting the SAE flange

The screws to be used and the instructions for mounting can be found in the instruction manual.

- 1) Pressure relief valve
- 2) Counterbalance valve, dual action
- 3) Counterbalance valve, single action

Counterbalance valve for travel drives BVD...F

Application option

- ▶ Travel drive for wheeled excavators (BVD and BVE)

▼ **Example circuit diagram for travel drive on wheeled excavators**

A6VM80HA1T/63W-VAB38800A + BVD20F27S/41B-V03K16D0400S12

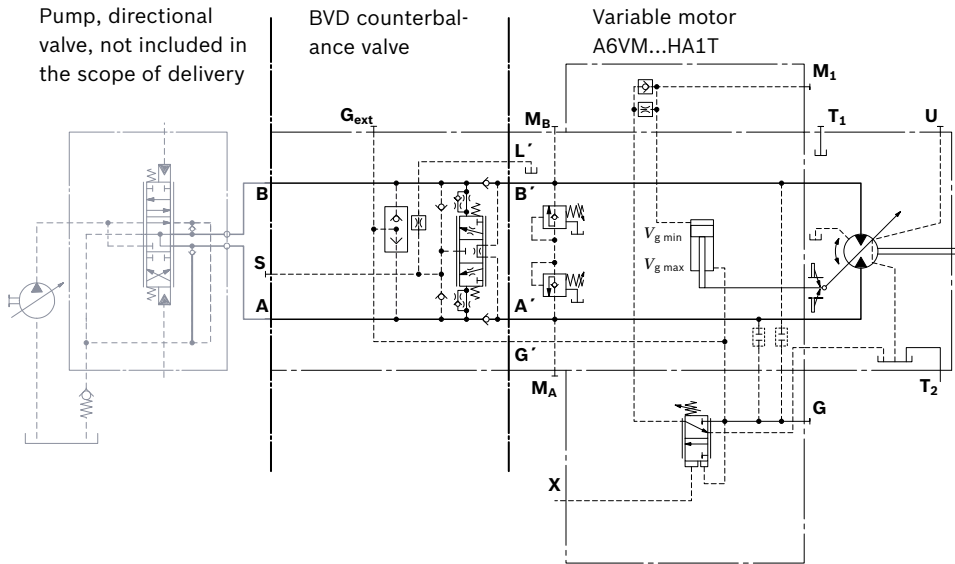

Counterbalance valve for winches and track drive BVD...W and BVE

Application option

- ▶ Winch drives in cranes (BVD and BVE)
- ▶ Track drive in excavator crawlers (BVD)

▼ **Example circuit diagram for winch drive in cranes**

A6VM80HD1D/63W-VAB38800B + BVE25W38S/51ND-V100K00D4599T30S00-0

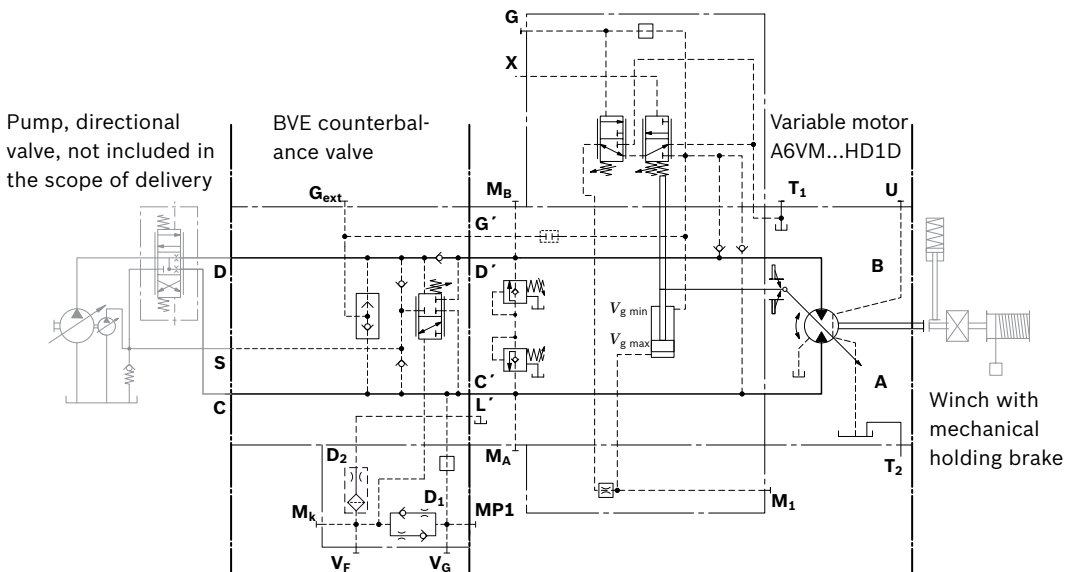

Dimensions

▼ **A6VM...HA**

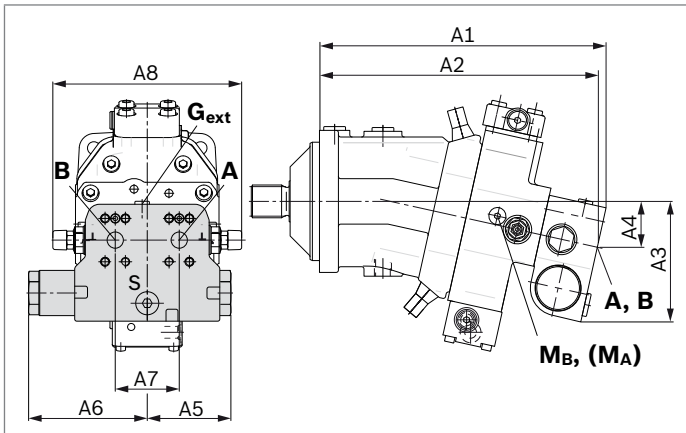

▼ **A6VM...HD1, HD2 or EP1, EP2¹⁾**

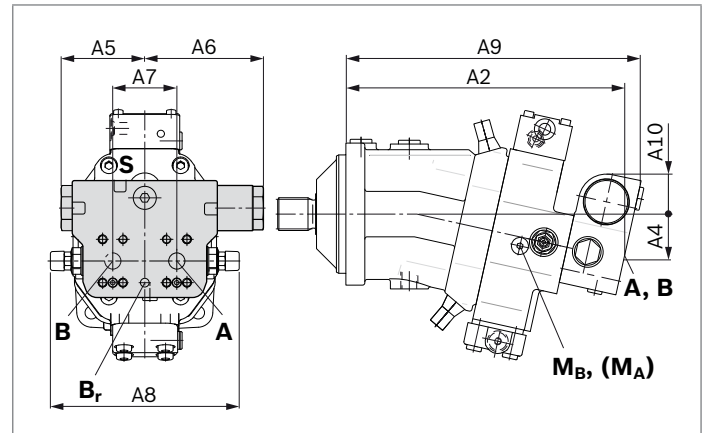

A6VM NG...plate	Counterbalance valve Type	Ports A, B	Dimensions									
			A1	A2	A3	A4	A5	A6	A7	A8	A9	A10
55...38	BVD20...17	3/4 in	311	302	143	50	98	139	75	222	326	50
80...38	BVD20...27	1 in	340	331	148	55	98	139	75	222	355	46
107...37	BVD20...28	1 in	362	353	152	59	98	139	84	234	377	41
107...38	BVD25...38	1 1/4 in	380	370	165	63	120.5	175	84	238	395	56
140...38	BVD25...38	1 1/4 in	411	401	168	67	120.5	175	84	238	426	53
160...38	BVD25...38	1 1/4 in	417	407	170	68	120.5	175	84	238	432	51
200...38	BVD25...38	1 1/4 in	448	438	176	74	120.5	175	84	299	463	46
107...38	BVE25...38	1 1/4 in	380	370	171	63	137	214	84	238	397	63
140...38	BVE25...38	1 1/4 in	411	401	175	67	137	214	84	238	423	59
160...38	BVE25...38	1 1/4 in	417	407	176	68	137	214	84	238	432	59
200...38	BVE25...38	1 1/4 in	448	438	182	74	137	214	84	299	463	52

Ports	Version	A6VM plate	Standard	Size ²⁾	P _{max} [bar] ³⁾	State ⁵⁾		
A, B	Working line		SAE J518	see table above	420	O		
S	Infeed	BVD20	DIN 3852 ⁴⁾	M22 × 1.5; 14 deep	30	X		
		BVD25, BVE25	DIN 3852 ⁴⁾	M27 × 2; 16 deep	30	X		
Br	Brake release, reduced high pressure	L		7	DIN 3852 ⁴⁾	M12 × 1.5; 12.5 deep	30	O
				8	DIN 3852 ⁴⁾	M12 × 1.5; 12 deep	30	O
G _{ext}	Brake release, high pressure	S	DIN 3852 ⁴⁾	M12 × 1.5; 12.5 deep	420	X		
MA, MB	Pressure measurement A and B		DIN 3852 ⁴⁾	M18 × 1.5; 14.5 deep	420	X		

1) At the mounting version for the controls HP5, HP6 and EP5, EP6, the cast-in port designations **A** and **B** on the BVD counterbalance valve do not correspond with the port designation of the A6VM motor. The designation of the ports on the installation drawing of the motor is binding!

2) For notes on tightening torques, see the instruction manual

3) Depending on the application, momentary pressure peaks can occur. Keep this in mind when selecting measuring devices and fittings.

4) The countersink can be deeper than as specified in the standard.

5) O = Must be connected (plugged when delivered)

X = Plugged (in normal operation)

Swivel angle indicator

Optical (V)

The swivel position is indicated by a pin on the side of the port plate. The length of pin protruding depends on the position of the lens plate.

If the pin is flush with the port plate, the motor is at the beginning of control. At maximum swivel, the pin length is 8 mm (visible after removing the cap nut).

▼ **Example: Beginning of control at $V_{g \max}$**

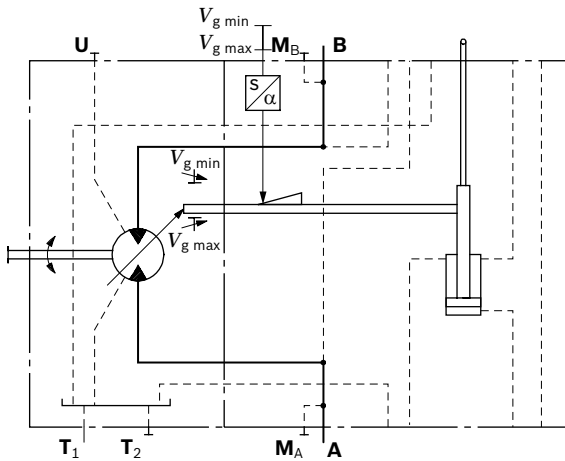

Electric (E)

The motor position is detected by an inductive position transducer. This converts the travel of the control device into an electric signal.

This signal is used to forward the swivel position to an electric control unit.

Inductive position transducer

Type of protection:

- ▶ IP65 (DIN/EN 60529)

▼ **Example: Beginning of control at $V_{g \max}$**

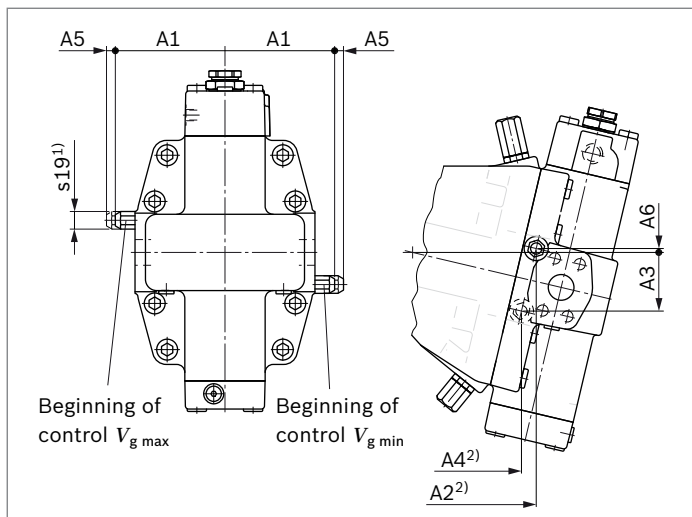
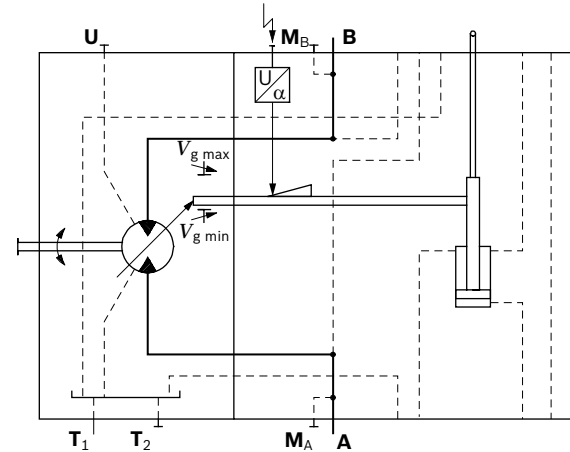

NG	A1	A2 ²⁾	A3	A4	A5 ³⁾	A6
250	136.5	256	73	238	11	5
355	159.5	288	84	266	11	8
500	172.5	331	89	309	11	3
1000	208.5	430	114	402	11	3

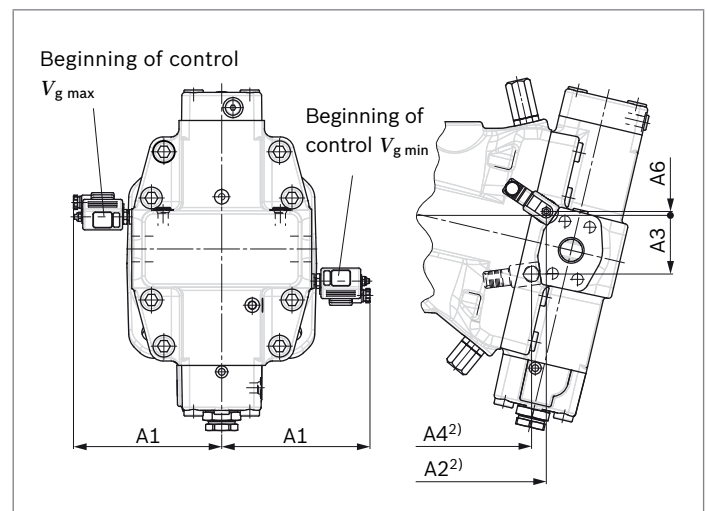

NG	A1	A2 ²⁾	A3	A4	A6
250	185	256	73	238	5
355	208	288	84	266	8
500	221	331	89	309	3
1000	257	430	114	402	3

1) Width across flats

2) Dimension to mounting flange

3) Required clearance for removal of cap nut

Speed sensor

Version A6VM...U (“prepared for speed sensor”, i.e. without sensor) is equipped with a spline on the rotary group. A signal proportional to motor rotational speed can be generated with the DSA/DSM or HDD speed sensor mounted. The DSA/DSM sensor registers the rotational speed and direction of rotation.

Type code, technical data, dimensions and parameters for the connector, plus safety instructions about the sensor can be found in the relevant data sheet 95132 – DSM, 95133 – DSA or 95135 – HDD.

The sensor is mounted on the port provided for this purpose with a mounting bolt. On deliveries without sensor, the port is plugged with a pressure-resistant cover. We recommend ordering the A6VM variable motor complete with mounted sensor.

▼ Circuit diagram

Sizes 28 to 200

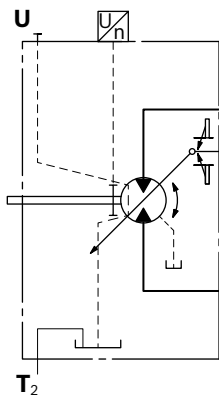

▼ Dimensions

Version “V” with DSA sensor or DSM sensor (sizes 28 to 200)

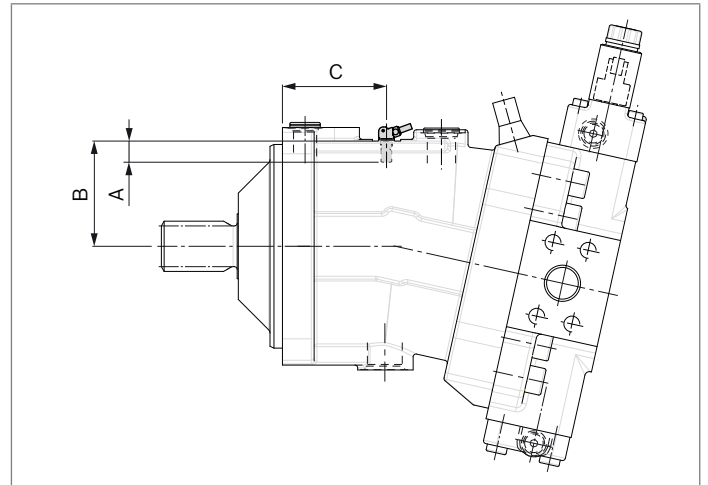

Version “H” with HDD sensor (sizes 250 to 500)

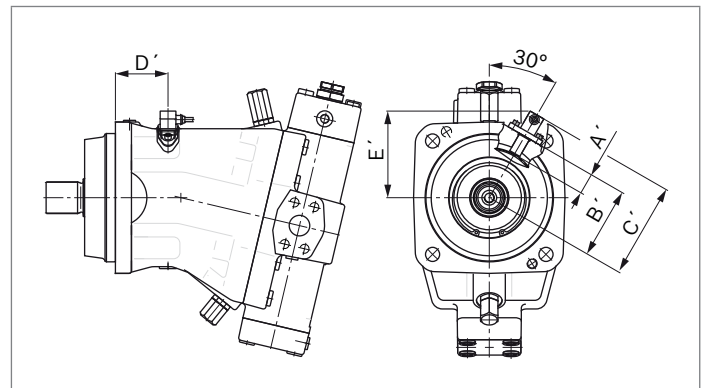

NG			28	55	80	107	140	160	200	250	355	500
	Number of teeth		40	54	58	67	72	75	80	78	78	90
DSA	A	Insertion depth (tolerance -0.25)	18.4	18.4	18.4	18.4	18.4	18.4	18.4	1) ¹⁾	1) ¹⁾	1) ¹⁾
	B	Contact surface	61	75	79	88	93	96	101	1) ¹⁾	1) ¹⁾	1) ¹⁾
	C		57.2	66.2	75.2	77.2	91.2	91.7	95.2	1) ¹⁾	1) ¹⁾	1) ¹⁾
HDD	A'	Insertion depth (tolerance ±0.1)	–	–	–	–	–	–	–	32.5	32.5	32.5
	B'	Contact surface	–	–	–	–	–	–	–	110.5	122.5	132.5
	C'		–	–	–	–	–	–	–	149	161	171
	D'		–	–	–	–	–	–	–	82	93	113
	E'		–	–	–	–	–	–	–	135	145	154

1) On request

Installation instructions

General

The axial piston unit must be filled with hydraulic fluid and air bled during commissioning and operation. This must also be observed following a longer standstill as the axial piston unit may empty via the hydraulic lines.

Particularly in the installation position “drive shaft upwards”, filling and air bleeding must be carried out completely as there is, for example, a danger of dry running. The leakage in the housing area must be directed to the reservoir via the highest drain port (**T₁**, **T₂**).

For combinations of multiple units, make sure that the respective case pressure in each unit is not exceeded. In the event of pressure differences at the drain ports of the units, the shared drain line must be changed so that the maximum permissible case pressure of all connected units is not exceeded at any operational conditions. If this is not possible, separate drain lines must be laid.

To achieve favorable noise values, decouple all connecting lines using elastic elements and avoid above-reservoir installation.

In all operating conditions, the drain line must flow into the reservoir below the minimum fluid level.

Notice

In certain installation positions, an influence on the control characteristic can be expected. Gravity, dead weight and case pressure can cause minor characteristic shifts and changes in response time.

Key	
F	Filling / air bleeding
U	Bearing flushing / air bleed port
T₁, T₂	Drain port
$h_{t\ min}$	Minimum required immersion depth (200 mm)
h_{min}	Minimum required distance to reservoir bottom (100 mm)

Installation position

See the following examples **1** to **8**.

Further installation positions are available upon request.
Recommended installation position: **1** and **2**

Below-reservoir installation (standard)

Below-reservoir installation means that the axial piston unit is installed outside of the reservoir and below the minimum fluid level of the reservoir.

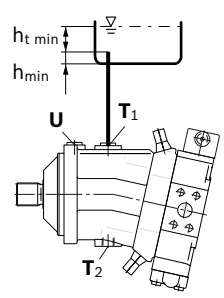
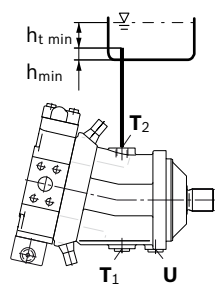
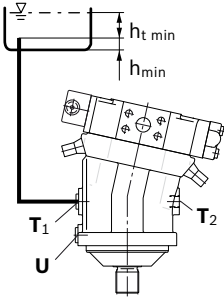
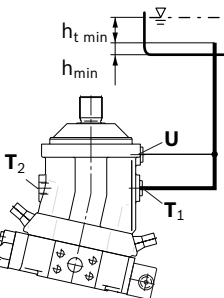
Installation position	Air bleed	Filling
<p>1</p> 		T₁
<p>2</p> 		T₂
<p>3</p> 		T₁
<p>4</p> 	U	T₁

Above-reservoir installation

Above-reservoir installation means that the axial piston unit is installed above the minimum fluid level of the reservoir.

Recommendation for installation position 8 (drive shaft upward):

A check valve in the reservoir line (cracking pressure 0.5 bar) can prevent draining of the housing area.

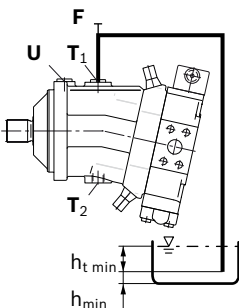
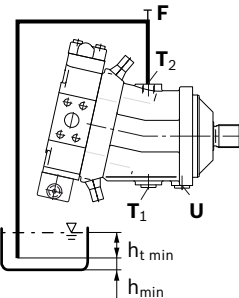
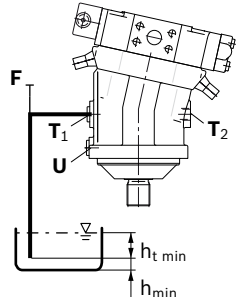
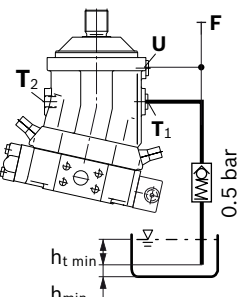
Installation position	Air bleed	Filling
<p>5</p> 	U (F)	T₁ (F)
<p>6</p> 	F	T₂ (F)
<p>7</p> 	F	T₁ (F)
<p>8</p> 	U	T₁ (F)

Notice

Port **F** is part of the external piping and must be provided on the customer side to make filling and air bleeding easier.

Project planning notes

- ▶ The motor A6VM is designed to be used in open and closed circuits.
- ▶ The project planning, installation and commissioning of the axial piston unit requires the involvement of qualified skilled personnel.
- ▶ Before using the axial piston unit, please read the corresponding instruction manual completely and thoroughly. If necessary, these can be requested from Bosch Rexroth.
- ▶ Before finalizing your design, please request a binding installation drawing.
- ▶ The specified data and notes contained herein must be observed.
- ▶ For safety reasons, controls with beginning of control at $V_{g \min}$ (e.g., HA) are not permissible for winch drives (e.g. anchor winches)!
- ▶ Depending on the operating conditions of the axial piston unit (working pressure, fluid temperature), the characteristic curve may shift.
- ▶ Preservation: Our axial piston units are supplied as standard with preservative protection for a maximum of 12 months. If longer preservative protection is required (maximum 24 months), please specify this in plain text when placing your order. The preservation periods apply under optimal storage conditions, details of which can be found in the data sheet 90312 or the instruction manual.
- ▶ Not all variants of the product are approved for use in safety functions according to ISO 13849. Please consult the responsible contact person at Bosch Rexroth if you require reliability parameters (e.g. $MTTF_d$) for functional safety.
- ▶ Depending on the type of control used, electromagnetic effects can be produced when using solenoids. When a direct current is applied, solenoids do not cause electromagnetic interference nor is their operation impaired by electromagnetic interference.
Other behavior can result when a modulated direct current (e.g. PWM signal) is applied. Potential electromagnetic interference for persons (e.g. persons with a pacemaker) and other components must be tested by the machine manufacturer.
- ▶ Please note the details regarding the tightening torques of port threads and other threaded joints in the instruction manual.
- ▶ Working ports:
 - The ports and fastening threads are designed for the specified maximum pressure. The machine or system manufacturer must ensure that the connecting elements and lines correspond to the specified application conditions (pressure, flow, hydraulic fluid, temperature) with the necessary safety factors.
 - The working ports and function ports are only intended to accommodate hydraulic lines.

Safety instructions

- ▶ During and shortly after operation, there is a risk of getting burnt on the axial piston unit and especially on the solenoids. Take appropriate safety measures (e.g. by wearing protective clothing).

- ▶ Moving parts in control equipment (e.g. valve spools) can, under certain circumstances get blocked in position as a result of contamination (e.g. impure hydraulic fluid, abrasion, or residual dirt from components). As a result, the hydraulic fluid flow and the build-up of torque in the axial piston unit can no longer respond correctly to the operator's specifications. Even the use of various filter elements (external or internal flow filter) will not rule out a fault but merely reduce the risk.

The machine/system manufacturer must check whether additional measures are required on the machine for the relevant application in order to bring the driven consumer into a safe position (e.g. safe stop) and ensure any measures are properly implemented.

- ▶ Moving parts in high-pressure relief valves may in certain circumstances become stuck in an undefined position due to contamination (e.g. contaminated hydraulic fluid). This can result in restriction or loss of the load holding function in lifting winches.

The machine/system manufacturer must check whether additional measures are required on the machine for the relevant application in order to keep the load in a safe position and ensure they are properly implemented.

- ▶ When using the axial piston motor in winch drives, make certain that the technical limit values are not exceeded under all operating conditions. If the axial piston motor is extremely overloaded (e.g., if the maximum permissible rotational speeds are exceeded during weighing of the anchor while the ship is in motion), the rotary group may be damaged and, in the worst case, the axial piston motor may burst. The machine manufacturer / system manufacturer is to undertake additional measures, up to and including encapsulation.

Bosch Rexroth AG

Mobile Applications
Glockeraustraße 4
89275 Elchingen, Germany
Tel. +49 7308 82-0
info.ma@boschrexroth.de
www.boschrexroth.com

© Bosch Rexroth AG 2016. All rights reserved, also regarding any disposal, exploitation, reproduction, editing, distribution, as well as in the event of applications for industrial property rights. The data specified within only serves to describe the product. No statements concerning a certain condition or suitability for a certain application can be derived from our information. The information given does not release the user from the obligation of own judgment and verification. It must be remembered that our products are subject to a natural process of wear and aging.