

3500 SERIES AIR SERVICE UNITS FILTER REGULATORS



- Specifically designed for Severe Offshore Environments
- Non or Self-relieving
- Manual or auto-drain
- 5 Micron element
- Easy Installation, Repair and Replacement
- Ambient Temperature Range -20°C to +80°C
- 316 Stainless Steel Construction
- Large flow paths minimise pressure drop
- 5 pressure ranges

General Description

A 316 Stainless Steel combined unit for filtration and regulation of compressed air in the offshore, petrochemical and allied industries.

Regulated Pressure

0.10	to	2 bar	(1.45	to	29psi)
0.20	to	4 bar	(2.90	to	58psi)
0.30	to	7 bar	(4.35	to	102psi)
0.50	to	10 bar	(7.25	to	145psi)
0.80	to	16 bar	(11.6	to	232psi)

Units ordered with a specified pressure range will be supplier complete with a pilot regulator piped using double ferrule fittings

Ports NPT (BSP option available)

- ¾", 1"

Gauge Ports (BSP option available)

- 1/8" NPT
- ¼" NPT (option available)

Relief Vent Port

- 1/8" NPT (Fitted with bug screen)

Flow Capacity

- At 7 bar (102 psi) inlet pressure
- 6 bar (87 psi) secondary pressure
- 1 bar (14.5 psi) pressure drop
- 7800 l/min (274 SCFM)

Ambient Temperature Range

- Standard: -20°C to +80°C (-4°F to +176°F)

Maximum Relief Flow

- At 2 bar (29psi) secondary pressure
- 0.5cc/sec (0.03 cu in/sec)

Working Pressure

- Manual drain - 20 bar (290 psi)
- Automatic drain - 17 bar (247 psi)

Bowl Retention Capacity

- 260cc (15.87 cu ins)

3500 SERIES AIR SERVICE UNITS FILTER REGULATORS

Filter Regulator with Manual Drain

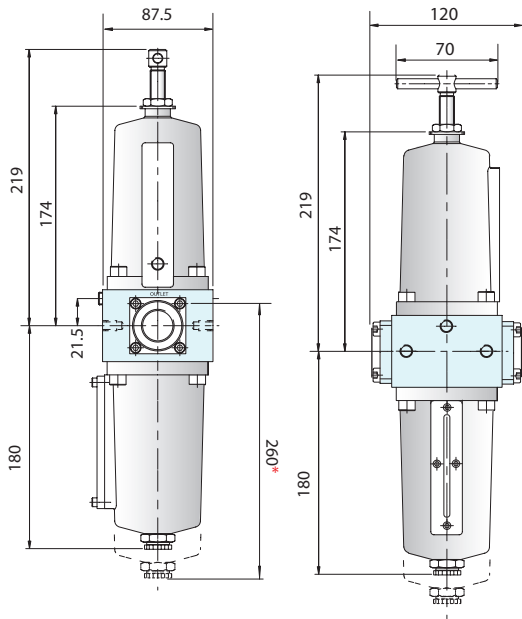

Filter Regulator with Automatic Drain

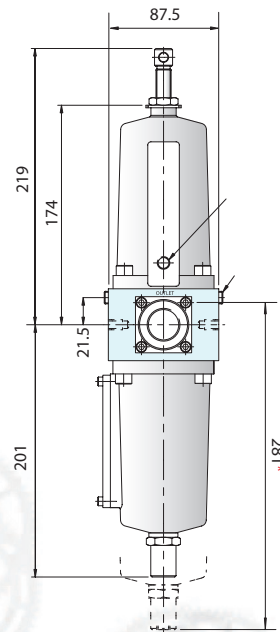

Self Reliving with manual drain

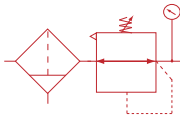

Non-Reliving with manual drain

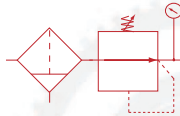

Self Reliving with automatic drain

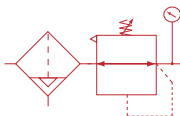

Non-Reliving with automatic drain

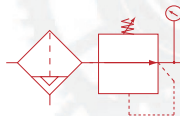

Ingress Protection

- IP65

Operating Medium

- Gases - air, inert gas, sweet (natural) and sour gases.

Weight

- 5.75 kg

Construction Materials

- Body/bonnet/bowl and internals: 316 Stainless Steel
- Element: Sintered Polypropylene
- Seals & valve assembly: Fluoroelastomer
- Diaphragm: Nitrile and 316 Stainless Steel
- Valve Spring: Inconel X750
- Adjustment Spring: 316 Stainless Steel

3500 SERIES AIR SERVICE UNITS FILTER



- Specifically designed for Severe Offshore Environments
- Manual or auto-drain
- 5 Micron element
- Easy Installation, Repair and Replacement
- Ambient Temperature Range -20°C to +80°C
- 316 Stainless Steel Construction
- Large flow paths minimise pressure drop

General Description

A 316 Stainless Steel unit for filtration of compressed air in the offshore, petrochemical and allied industries.

Regulated Pressure

0.10	to	2 bar	(1.45	to	29psi)
0.20	to	4 bar	(2.90	to	58psi)
0.30	to	7 bar	(4.35	to	102psi)
0.50	to	10 bar	(7.25	to	145psi)
0.80	to	16 bar	(11.6	to	232psi)

Units ordered with a specified pressure range will be supplied complete with a pilot regulator piped using double ferrule fittings

Ports NPT (BSP option available)

- ¾", 1"

Gauge Ports (BSP option available)

- 1/8" NPT
- ¼" NPT (option available)

Ambient Temperature Range

- Standard: -20°C to +80°C (-4°F to +176°F)

Working Pressure

- Manual drain - 20 bar (290 psi)
- Automatic drain - 17 bar (247 psi)

Bowl Retention Capacity

- 260cc (15.87 cu ins)

Flow Capacity

At 7 bar (102 psi) inlet pressure

0.35 bar (5 psi) pressure drop

- 10020 l/min (353 SCFM)

3500 SERIES AIR SERVICE UNITS FILTER

Filter with Manual Drain

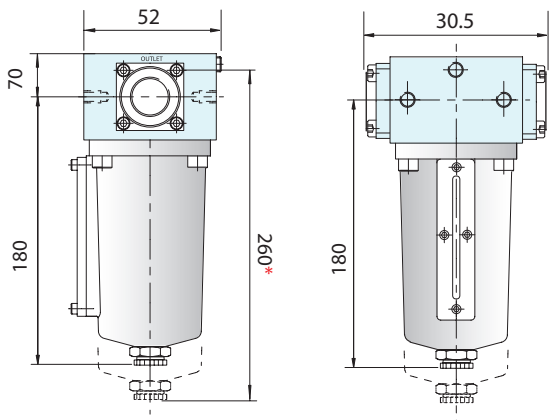

Filter with manual drain



Filter with automatic drain



Filter with Automatic Drain

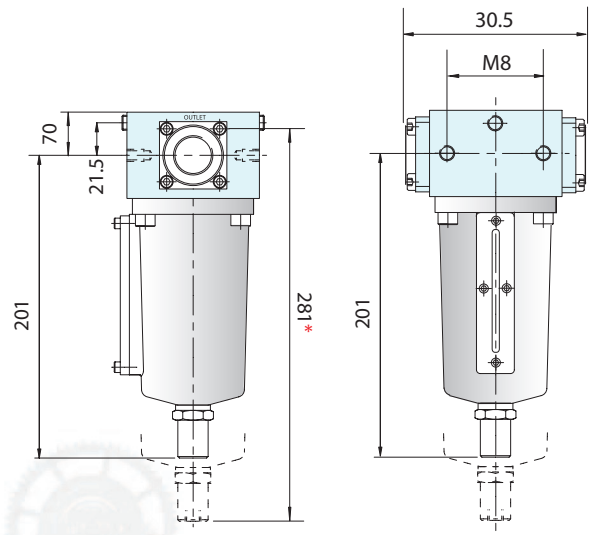

Ingress Protection

- IP65

Construction Materials

- Body/bonnet/bowl and internals: Stainless Steel AISI 316 S11
- Element: Sintered Polypropylene
- Seals: Fluoroelastomer

Operating Medium

- Gases - air, inert gas, sweet (natural) and sour gases (option).

Weight

3.75 kg

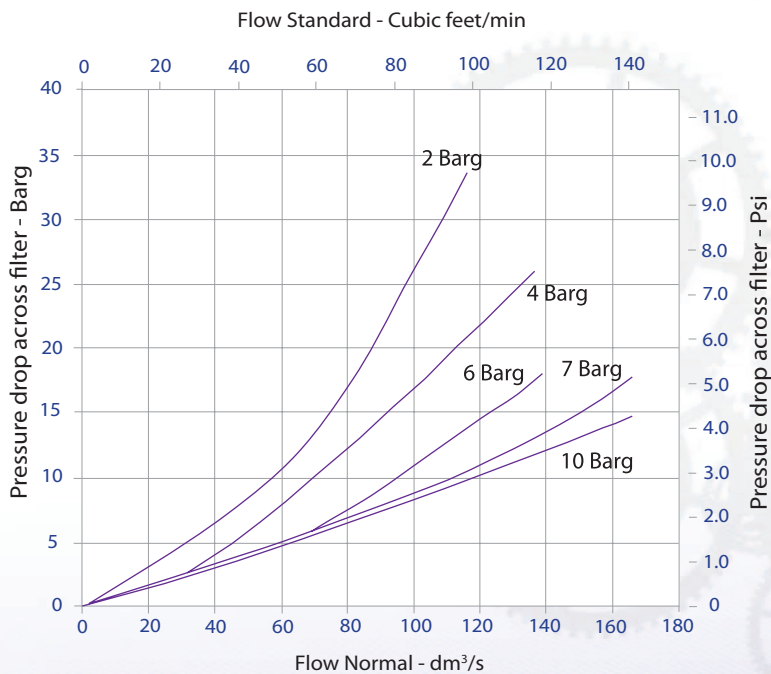

3500 SERIES AIR SERVICE UNITS REGULATOR

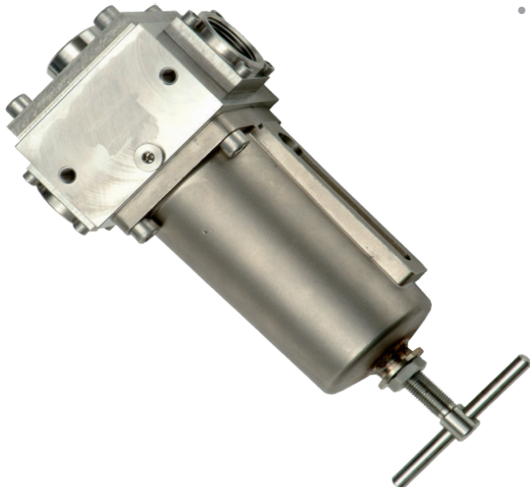

- Specifically designed for Severe Offshore Environments
- Non or Self-relieving
- 4 pressure ranges
- High relief flow
- Easy Installation, Repair and Replacement
- Ambient Temperature Range -20°C to +80°C
- 316 Stainless Steel Construction
- Large flow paths minimise pressure drop

General Description

A 316 Stainless Steel unit for pressure regulation of compressed air in the offshore, petrochemical and allied industries.

Regulated Pressure

0.10	to	2 bar	(1.45	to	29psi)
0.20	to	4 bar	(2.90	to	58psi)
0.30	to	7 bar	(4.35	to	102psi)
0.50	to	10 bar	(7.25	to	145psi)
0.80	to	16 bar	(11.6	to	232psi)

Units ordered with a specified pressure range will be supplier complete with a pilot regulator piped using double ferrule fittings

Ambient Temperature Range

- Standard: -20°C to +80°C (-4°F to +176°F)

Ports NPT (BSP option available)

- ¾", 1"

Maximum Relief Flow

- At 2 bar (29psi) secondary pressure
0.5cc/sec (0.03 cu in/sec)

Gauge Ports (BSP option available)

- 1/8" NPT
- ¼" NPT (option available)

Flow Capacity

- At 7 bar (102 psi) inlet pressure
6 bar (87 psi) secondary pressure
1 bar (14.5 psi) pressure drop
- 7800 l/min (274 SCFM)

Relief Vent Port

- 1/8" NPT (Fitted with bug screen)

3500 SERIES AIR SERVICE UNITS REGULATOR

Self-relieving and Non-relieving

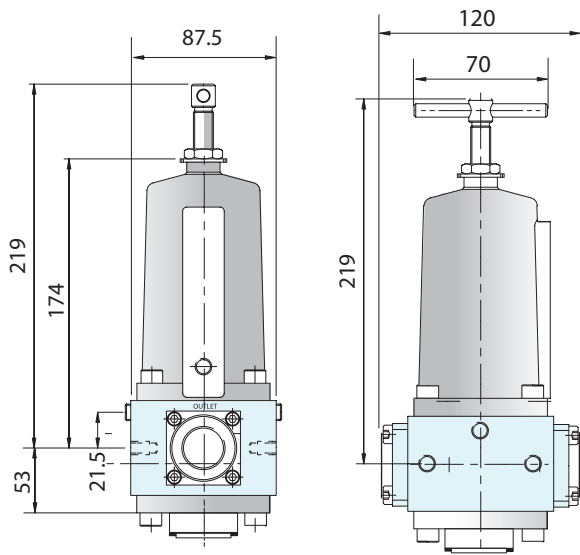

Self Reliving pressure regulator

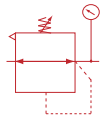

Non-Reliving pressure regulator

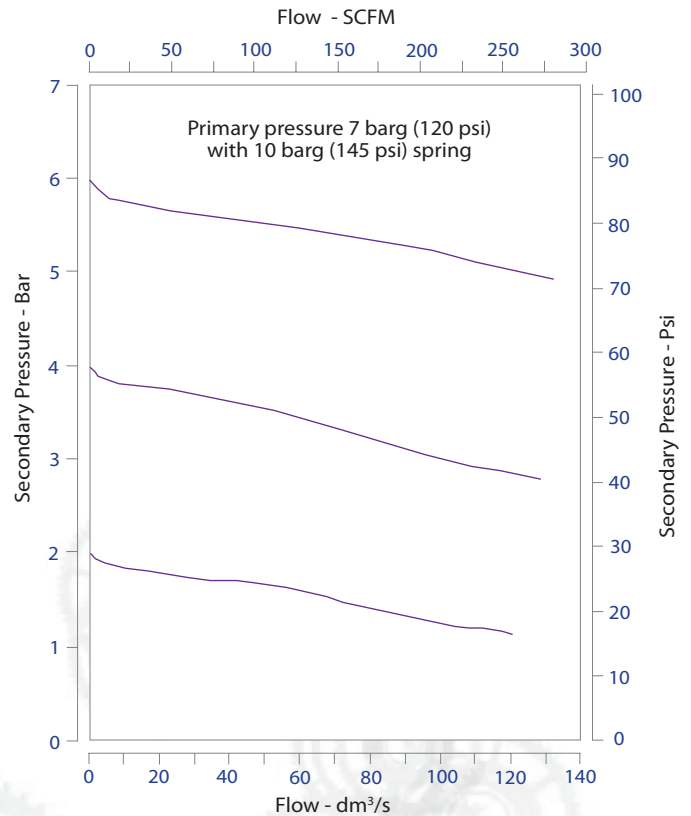
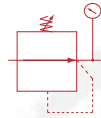

Ingress Protection

- IP65

Construction Materials

- Body/bonnet/bowl and internals:
Stainless Steel AISI 316 S11
- Seals & valve assembly: Fluoroelastomer
- Diaphragm: Nitrile and 316 Stainless Steel
- Valve Spring: Inconel X750
- Adjustment Spring: 316 Stainless Steel

Operating Medium

- Gases - air, inert gas, sweet (natural) and sour gases.

Weight

5.00 kg (¾", 1")

3500 SERIES AIR SERVICE UNITS LUBRICATOR



- *Specifically designed for Severe Offshore Environments*
- *Accurate drip rate adjustment*
- *Can be filled under pressure*
- *Transparent sight feed dome*
- *Easy Installation, Repair and Replacement*
- *Ambient Temperature Range -20°C to +80°C*
- *316 Stainless Steel Construction*
- *Built in flow sensor to automatically adjust lubrication delivery to meet wide air flow demand*

General Description

A 316 Stainless Steel unit providing lubrication of compressed air for offshore and allied industries

Ambient Temperature Range

- Standard: -20°C to +80°C (-4°F to +176°F)

Ports NPT (BSP option available)

- 1/2"

Working Pressure

- 17 bar (247 psi)

Construction Materials

- Body/bonnet/bowl and internals: Stainless Steel 316
- Seals: Fluoroelastomer and Nitrile
- Bowl: 316 Stainless Steel
- Acrylic flow and sight glass

Bowl Retention Capacity

- 380cc (23.2 cu ins)

Ingress Protection

- IP65

3500 SERIES AIR SERVICE UNITS LUBRICATOR

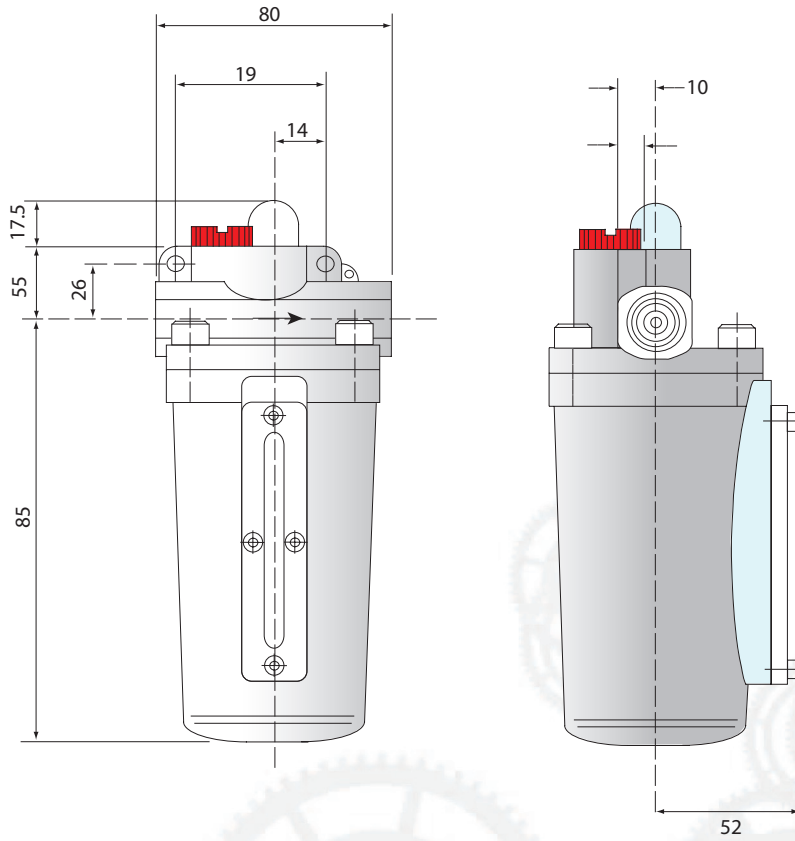

Operating Medium

- Gases - air, inert gas, sweet (natural)

Weight

1.80 kg

Function
Symbol

