

Level Measurement

Continuous level measurement – Ultrasonic transducers

ST-H

Overview



ST-H transducers use ultrasonic technology to measure level in chemical storage and liquid tanks.

Benefits

- Can be mounted on a 2 inch (50.8 mm) standpipe
- Immune to corrosive and harsh environments
- Integral temperature sensor

Application

The narrow design of the ST-H allows the transducer to be mounted on a 2 inch (50.8 mm) standpipe. When mounted correctly, it is completely protected from the process and can even be used in harsh, corrosive environments.

During operation, the ultrasonic transducer emits acoustic pulses in a narrow beam perpendicular to the transducer face. The level transceiver measures the propagation time between pulse emission and reception of the echo to calculate the distance from the transducer to the material. Variations in sound velocity due to changes in temperature within the permissible range are automatically compensated by the integral temperature sensor.

- Key Applications: chemical storage, liquid tanks

Technical specifications

Mode of operation	
Measuring principle	Ultrasonic transducer
Input	
Measuring range	0.3 ... 10 m (1 ... 33 ft)
Output	
Frequency	44 kHz
Beam angle	12°
Accuracy	
Temperature compensation	Compensated by integral temperature sensor
Rated operating conditions	
Pressure	Normal atmospheric pressure
Ambient conditions	
• Ambient temperature	-20 ... +60 °C (-5 ... +140 °F) (ATEX approved model) -40 ... +73 °C (-40 ... +163 °F) (CSA/FM approved model)
Design	
Weight ¹⁾	1.4 kg (3 lb)
Material (enclosure)	Base and lid made of ETFE or PVDF (epoxy fitted joint) ²⁾
Process connection	2" NPT [(Taper), ANSI/ASME B1.20.1], R 2" [(BSPT), EN 10226] or G 2" [(BSPP), EN ISO 228-1]
Degree of protection	IP68
Cable connection	2-core shielded/twisted, 0.519 mm ² (20 AWG), PVC sheath
Cable (max. length)	365 m (1 200 ft) with RG 62 A/U coaxial cable
Options	
• Flange adapter	3" Universal (fits DN 65, PN 10 and 3" ASME)
Certificates and approvals	
CE ³⁾ , CSA Class I, II, III, Div. 1, Groups A, B, C, D, E, F, G T3 (ETFE only), FM Class I, II, Div. 1, Groups C, D, E, F, G T4A, ATEX II 2G EEx m IIC T5, C-TICK, INMETRO: Br-Ex m II T5	

¹⁾ Approximate shipping weight of transducer with standard cable length

²⁾ When measuring chemicals, check compatibility of ETFE or PVDF and epoxy, or mount joint external to process.

³⁾ EMC certificate available on request

Level Measurement

Continuous level measurement – Ultrasonic transducers

ST-H

Selection and Ordering data

EchoMax ST-H ultrasonic transducer

Level measurement in chemical storage and liquid tanks. The narrow design of the ST-H allows the transducer to be mounted on a 2 inch standpipe. Measuring range: min. 0.3 m (1 ft), max. 10 m (33 ft).

Process connection

ETFE, 2" NPT [(Taper), ANSI/ASME B1.20.1]

ETFE, R 2" [(BSPT), EN 10226]

ETFE, G 2" [(BSPP), EN ISO 228-1]

PVDF copolymer, 2" NPT [(Taper), ANSI/ASME B1.20.1]

PVDF copolymer, R 2" [(BSPT), EN 10226]

PVDF copolymer, G 2" [(BSPP), EN ISO 228-1]

Cable length

5 m (16.40 ft)

10 m (32.81 ft)

30 m (98.43 ft)

50 m (164.04 ft)

100 m (328.08 ft)

Approvals

FM Class I, II, Div. 1, C-TICK³⁾

ATEX II 2G, CSA, C-TICK, INMETRO¹⁾

ATEX II 2G, C-TICK, INMETRO²⁾

Operating Instructions

Quick Start Manual, multi-language

Applications Guidelines, multi-language

Note: The Applications Guidelines should be ordered as a separate line item on the order.

This device is shipped with the Siemens Milltronics manual DVD containing the ATEX Quick Start and Operating Instructions library.

¹⁾ Available with Process connection options 0 ... 2 only

²⁾ Available with Process connection options 3 ... 5 only

³⁾ Not suitable for Ketone, Hexane, Ester or Ethyl Acetate atmospheres

Article No.

7ML1100-

0 A 0

0

1

2

3

4

5

A

B

C

D

E

2

3

4

Article No.

A5E32105880

7ML1998-5HV61

Selection and Ordering data

Further designs

Please add "-Z" to Article No. and specify Order code(s).

Acrylic coated, stainless steel tag [13 x 45 mm (0.5 x 1.75 inch)]: Measuring-point number/identification (max. 16 characters) specify in plain text

Accessories

Universal box bracket, mounting kit

3" ASME, DN 65 PN 10, JIS 10K 3B ETFE flange adapter for 2" NPT

3" ASME, DN 65 PN 10, JIS 10K 3B ETFE flange adapter for 2" BSPT

Easy Aimer 2, NPT with ¾" x 1" PVC coupling

Easy Aimer 2, aluminum with M20 adapter and 1" and 1½" BSPT aluminum couplings

Easy Aimer 304, with stainless steel coupling

Easy Aimer 304, with M20 adapter and 1" and 1½" BSPT 304 stainless steel couplings

Order code

Y17

Article No.

7ML1830-1BK

7ML1830-1BT

7ML1830-1BU

7ML1830-1AQ

7ML1830-1AX

7ML1830-1AU

7ML1830-1GN

Level Measurement

Continuous level measurement – Ultrasonic transducers

ST-H

Dimensional drawings

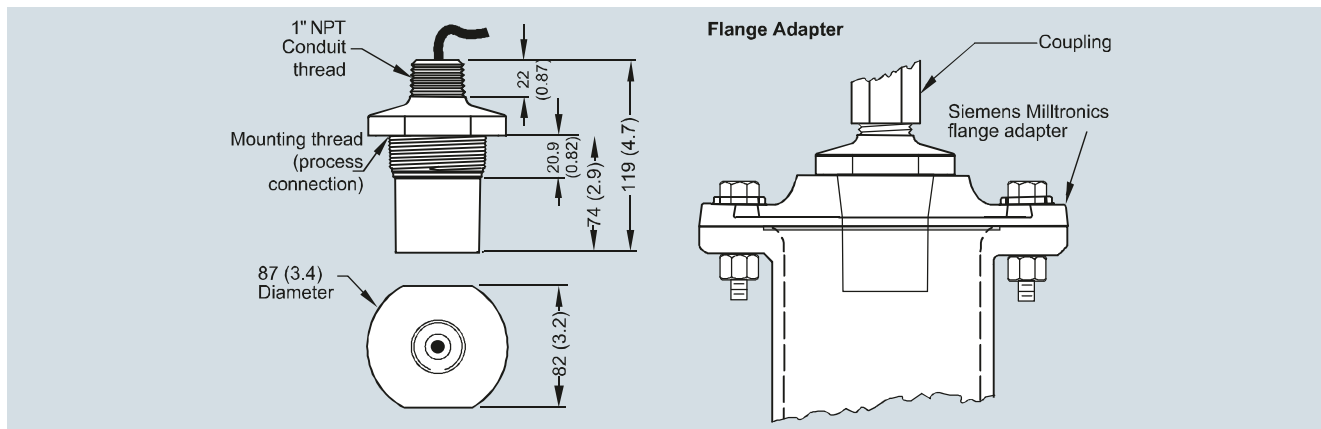

ST-H ultrasonic transducer, dimensions in mm (inch)

Schematics

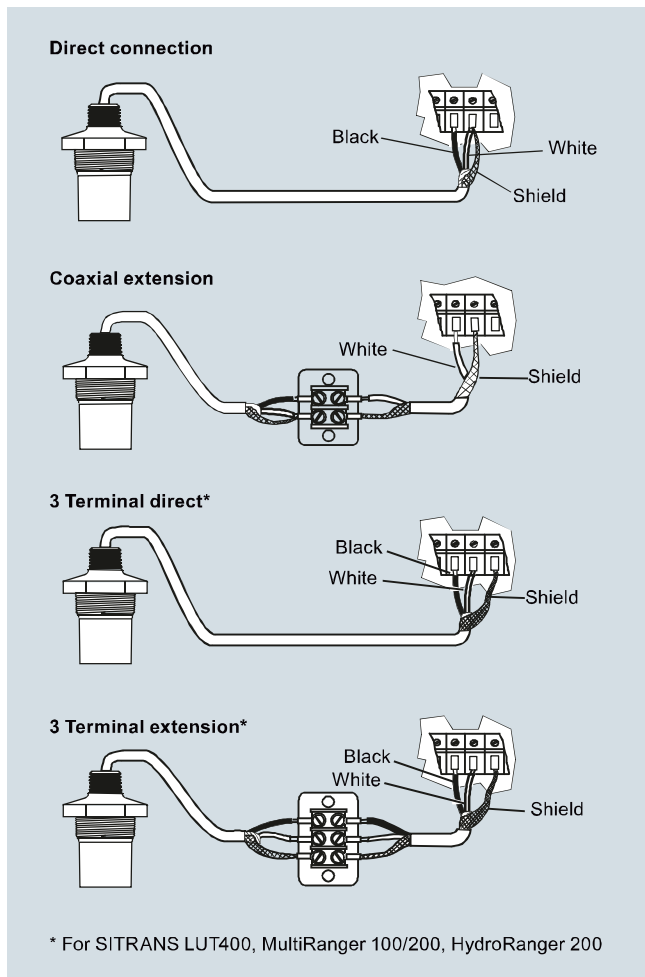

ST-H ultrasonic transducer connections

4