

DEPIC 2 HART POSITION TRANSMITTER - MODELS D510 AND D520

INSTALLATION AND OPERATIONS MANUAL

Quick start installation and operating instructions for models D510 with non-intrusive calibration and D520 without non-intrusive calibration

1 INTRODUCTION

1.1 Product Certification

IEC Ex

IECEx FMG 15.0036X
Ex db IIB+H2 T5 Gb Ta= -50°C to 85°C
Ex tb IIIC T88°C Db
Ta=-50°C to + 85°C
IP66/67



FM15ATEX0061X
II 2 G Ex db IIB+H2 T5 Gb
Ta= -50°C to +85°C
II 2 D Ex tb IIIC T88°C Db
Ta=-50°C to + 85°C
IP66/67



CLASS I DIVISION1, Groups B, C, and D.
CLASS II/III, DIVISION 1, Groups E,F, and G
TYPE 4, 4x IP66/67
Ta= -50°C to 85°C
CLASS1, ZONE 1, AEx db IIB+H2 Gb
ZONE 21, AEx/Ex tb IIIC T88°C Db
Ta= -50°C to 85°C



Warnings

- Models D510 and D520 contain aluminum and is at potential risk of ignition by impact or friction. Care must be taken into account during installation and use to prevent impact or friction.
- Never remove enclosure cover or make/break electrical connections with power connected to the unit.
- Perform all wiring in accordance with site and local codes and the National Electric Code ANSI-NFPA-70 (US) or the Canadian Electric Code Part I (Canada) for the appropriate area classifications.
- Confirm that the DEPIC2 model being installed is approved for the hazardous area (consult unit identification label).
- Confirm that power supplied to switches and solenoid is within rated specifications listed on the unit identification label.
- Protect the unit from exposure to aggressive substances or atmospheres to ensure that hazard rating is not compromised.
- Disconnect power to solenoids and the inlet air supply before conducting any valve service or maintenance. Avoid the introduction of any contaminants into the valve.
- Before using these products with fluids/ compressed gases other than air or for non-industrial applications, consult the factory. This product is not intended for use in life support systems.
- Installation in poorly ventilated confined areas, with any potential of gases other than oxygen being present, can lead to a risk of personnel asphyxiation.

2 INITIAL SETUP

2.1 Mounting transmitter on a rotary actuator

- Step 1 Mount bracket and inner beacon coupler to actuator. If actuator shaft has a tapped hole, fasten using proper flat head screw. If actuator does not have a tapped hole, fasten using set screws on side of coupler. (See Figure 2-1)
- Step 2 Press fit the inner beacon to the inner beacon coupler. The inner beacon needs to be properly oriented. Use the symbols on the top of the inner beacon to mount as shown in Condition 1 or Condition 2. (see Figure 2-2). Condition 1 and Condition 2 show the placement of the inner beacon with respect to the Transmitter housing while the actuator is in the fail position.
- Step 3 Mount the Transmitter to the bracket. As stated in Step 2 make sure that the Transmitter is mounted in a fashion that properly orients it with respect to the inner beacon.

Figure 2-1
BRACKET / COUPLER MOUNTING

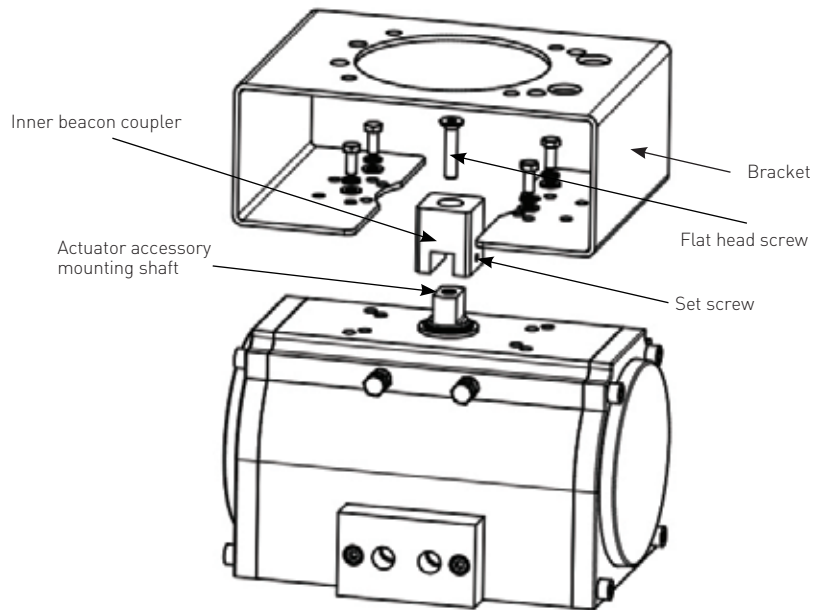
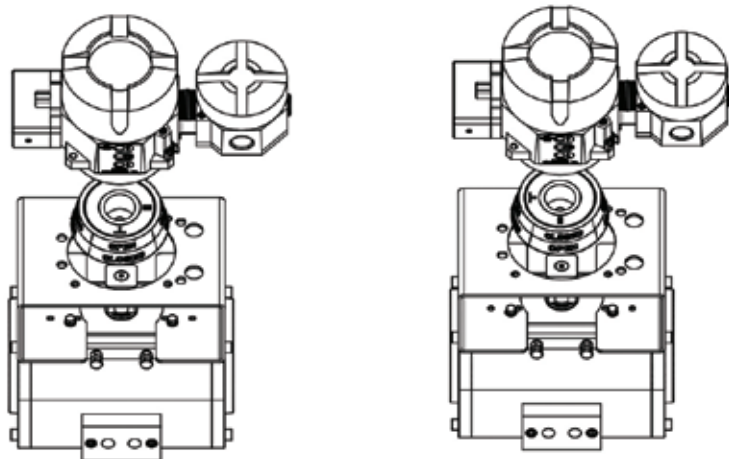

Figure 2-2
DIRECT MOUNT BEACON ORIENTATION



Condition 1: Actuator fails in a clockwise direction.

Condition 2: Actuator fails in a counter clockwise direction.

┌ Placed at 6:00
 || Placed at 3:00

┌ Placed at 9:00
 || Placed at 6:00

DEPIC 2 HART POSITION TRANSMITTER - MODELS D510 AND D520

INSTALLATION AND OPERATIONS MANUAL

2.2 Remote mount

- Step 1 Mount bracket and inner beacon coupler to actuator as described in Section 2.1 Step 1.
- Step 2 Press fit the inner beacon to the inner beacon coupler. The inner beacon needs to be properly oriented. Use the symbols on the top of the inner beacon to mount as shown in Condition 1 or Condition 2. (See Figure 2-3). Condition 1 and Condition 2 show the placement of the inner beacon with respect to the position sensor housing while the actuator is in the fail position.
- Step 3 Mount the position sensor to the bracket. As stated in Step 2 make sure that the position sensor is mounted in a fashion that properly orients it with respect to the inner beacon.

Figure 2-3
REMOTE MOUNT BEACON ORIENTATION

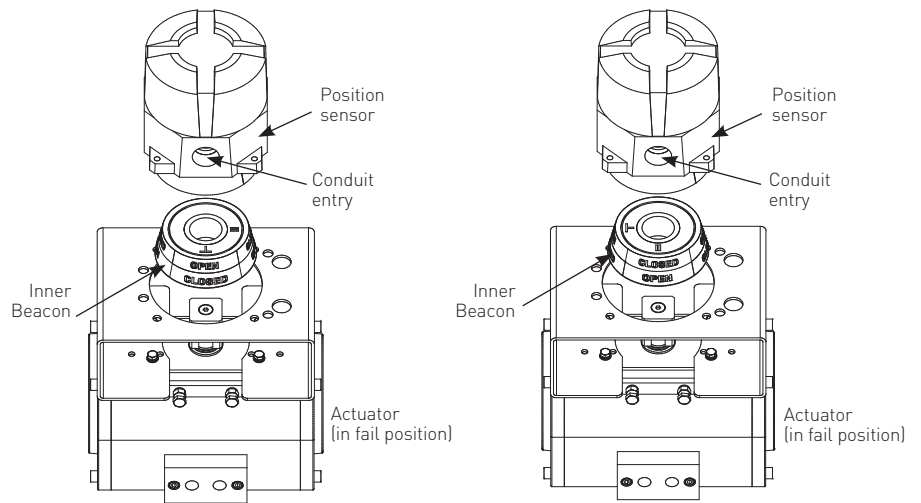

Condition 1: Actuator fails in a clockwise direction.

Condition 2: Actuator fails in a counter clockwise direction.

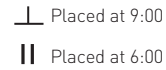
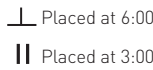

3 PNEUMATIC CONNECTIONS

3.1 DEPIC Transmitters with the Pressure Profiling feature enabled requires pneumatic pressure for both the supply pressure and output pressure.

NOTE

The pneumatic diagram shows a typical 3/2 solenoid valve. Option available of a factory fitted 3/2 solenoid valve in the DEPIC 520 Only.

3.2 The air supply to the DEPIC2 must be clean, dry, oil free instrument air per ANSI/ISA-7.0.01-1996 and ISO 8573-1:2010 or later.

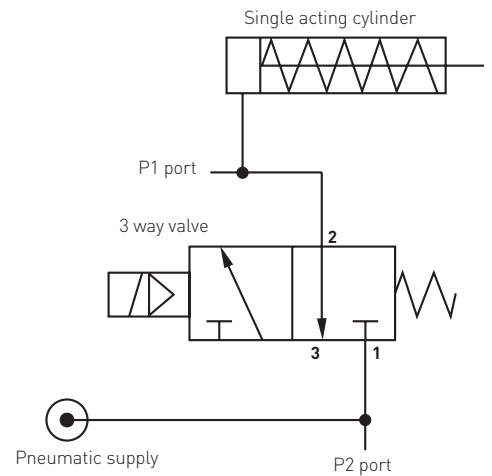
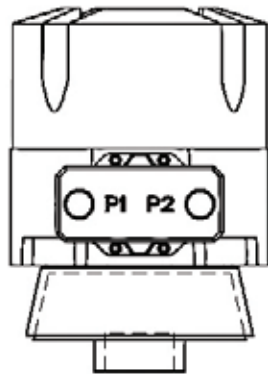

MAXIMUM PARTICLE SIZE AND CONCENTRATION OF SOLID CONTAMINANTS

Class	Maximum particle size (microns)	Maximum concentration (mg/m ³)
3	5	5

MAXIMUM OIL CONTENT

Class	Maximum concentration (mg/m ³)
3	1

Maximum supply pressure is 120 psi.
All pneumatic connections are 1/4" NPT or BSP.

DEPIC 2 HART POSITION TRANSMITTER - MODELS D510 AND D520

INSTALLATION AND OPERATIONS MANUAL

4 FIELD WIRING



Warning

See the warnings section of this document for important warnings pertaining to the wiring of the DEPIC Transmitters. Ensure care is taken with removing that fitting the Exd cover before and after wiring.

- 4.1 The DEPIC2 has been certified for use in hazardous locations to international standards. Although wiring practices may vary from region to region it is up to the end user to ensure that the electrical codes for installation have been satisfied.
- 4.2 All unused cable entries must be plugged with suitably certified plugs that can maintain an ingress protection level of IP66.
- 4.3 For ambient temperatures below -10°C and above +60°C, use field wiring suitable for both minimum and maximum ambient temperatures.
- 4.4 Electromagnetic compatibility (emissions and susceptibility) is guaranteed only if, the unit and all cables are shielded and grounded as illustrated in Appendix A.

If the DEPIC2 is optional with a Remote Mount, reference to full technical manual document, VCIOM-05044.

1. Remove cover from enclosure.
2. Locate terminal strip (for Exd option terminal strip is removable, See illustration on right).
3. Connect the 4 to 20 mA loop signal to terminal points marked 1 and 2. The 4-20 mA analog output is of the current sink type. Typically the 24 VDC supply required comes from the HOST system (24VDC nominal). See figure 4-1 for a wiring schematic.
4. Connect the solenoid coil to terminal points 3 and 4. See figure 4-1 for wiring. Solenoid coil is 24V with current not to exceed 500 mA. Power to activate the solenoid comes from a Safety Instrumented System logic solver 24V output and is connected to terminals 5 and 6. See figure 4-1 for wiring schematic. The SIS logic solver output must be able to provide sufficient current to operate the solenoid.
5. Connect electrical ground wire to green screw on housing (ground). Do not connect cable shield to ground. Cable shield at this end should be isolated using a shrink tubing or isolation tape.

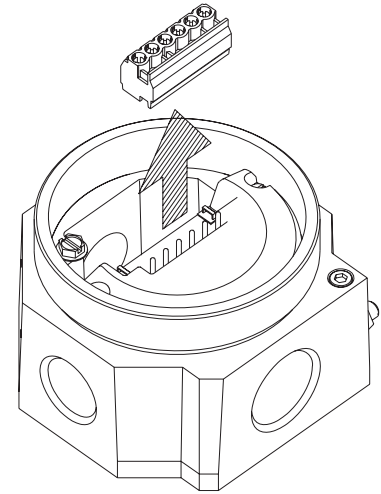

6. External grounding is required for all zone installations. All wiring must be done in accordance with local and national electric code. See figure 4-1 for external ground connection.
7. After all connections have been made (for Exd option reconnect the terminal strip) replace cover.

CAUTION

Do not over tighten Terminal Screws. Max Torque 3.5 in-lbs. /0.4 N-m.

All unused cable entries must be plugged with suitably certified plugs that can maintain an ingress protection level of IP66.

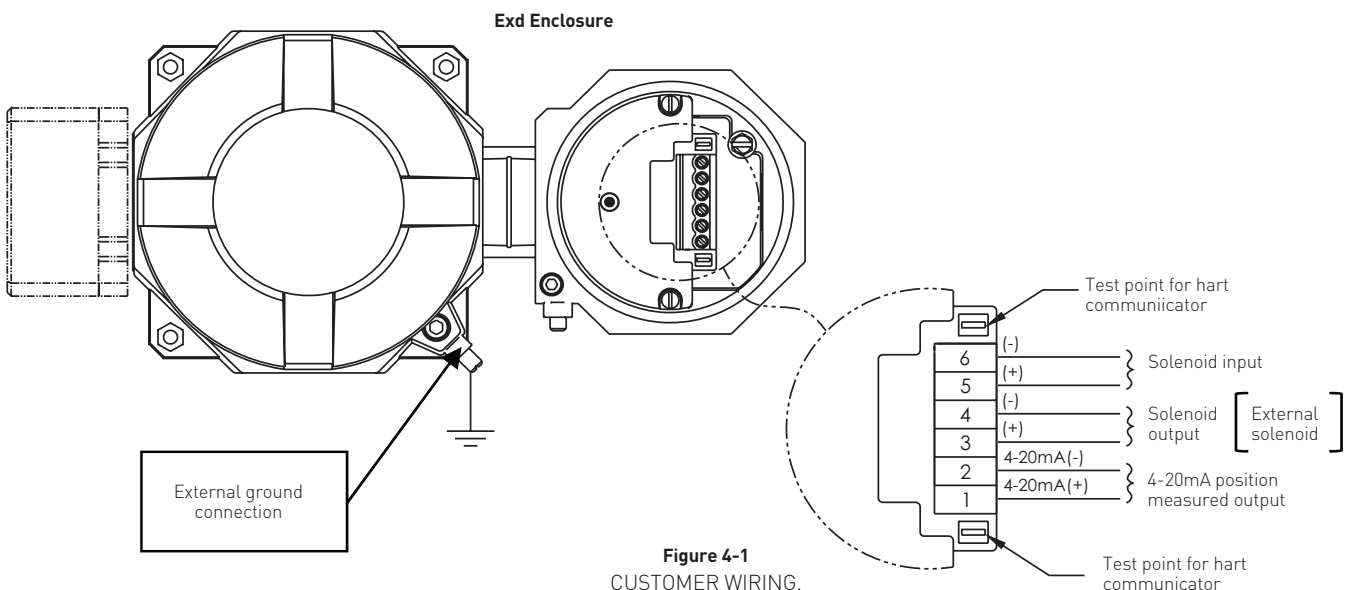

DEPIC 2 HART POSITION TRANSMITTER - MODELS D510 AND D520

INSTALLATION AND OPERATIONS MANUAL

4.5 Electrical connections for remote mount

- 4.5.1 Remove cover from junction enclosure by screwing 'clockwise' the cover retaining screw using a 9/64 A/F Allen Key.
- 4.5.2 Locate terminal board mounting screws (See Figure 4-2), remove the two screws and lift up terminal board. (See Figure 4-3).
- 4.5.3 Locate J3 and J4 connectors on the bottom of terminal board and connect the two part remote cable plugs as shown. See Figure 4-4.
- 4.5.4 Replace the terminal strip board, replace the screws and replace the cover.

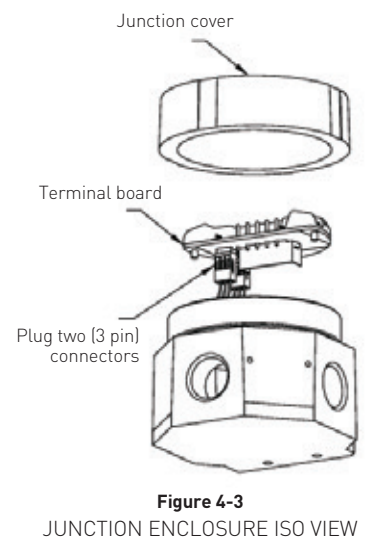
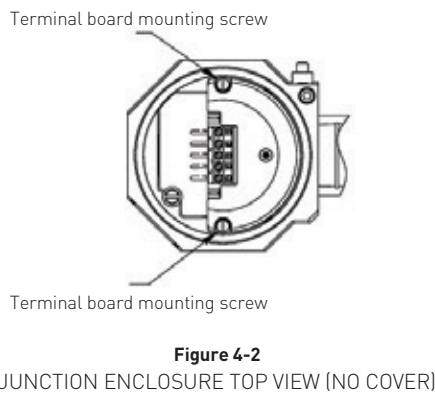

NOTE

To maintain the approval compliance, ensure that the junction enclosure cover locking screw is used. Screw the cover down to create a water tight seal, then rotate the locking screw anti-clockwise until the head of the screw mates with the underside of the cover. See Appendix B.

- 4.5.5 If necessary, cut the remote cable to required length.

NOTE

When shortening the cable, ensure to cut the end opposite female connector.

- 4.5.6 Locate remote transmitter enclosure and remove cover.
- 4.5.7 Wire the cable from junction enclosure to remote transmitter. See Figure 4-5.
- 4.5.8 After all connections have been made replace remote transmitter cover.

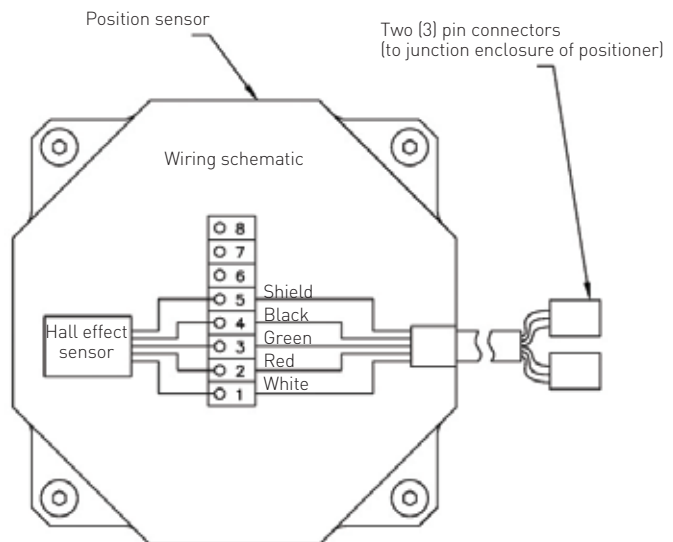
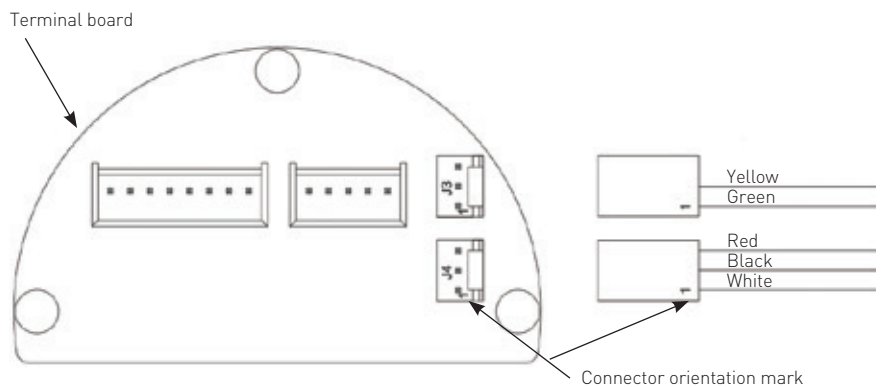



DEPIC 2 HART POSITION TRANSMITTER - MODELS D510 AND D520

INSTALLATION AND OPERATIONS MANUAL

5 QUICK SETUP

5.1 The DEPIC-2 can be configured for the basic operation and calibrated through the local user interface of LCD and Keypad. When the DEPIC-2 is shipped from the factory, it has all factory defaults settings. However the user has to configure a few basic settings and calibrate the device depending on the user configuration of the DEPIC-2. The Quick Setup provides an easy and intuitive way to configure the basic settings, calibrate and get the DEPIC-2 up and running within few minutes.

5.2 When the user presses the  key to enter the menu the first time after receiving from the factory, the DEPIC-2 will ask the user if he wants to run the Quick Setup as shown below. The user can select "Yes" or "No" to run or exit the Quick Setup. If the user selects to run the Quick Setup, the DEPIC-2 will guide the user step by step to enter all required settings and calibrate the device. The DEPIC-2 must be mounted on an actuator with proper electrical and pneumatic connections before running the Quick Setup. The following section explains each step in the Quick Setup.

5.3 Using the up/down arrow keys, toggle until 'YES' is displayed. Then press the  key to run the Quick Setup when the DEPIC-2 shows following screen on the LCD.

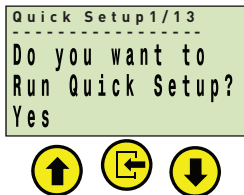

5.4 The LCD will display the following screen to configure the DEPIC-2 for the Rotary or Linear application. Use the up/down arrow key to change the selection between "Rotary" and "Linear". Press the Select key to accept the current selection.

Rotary: For rotary actuators, it should be selected as rotary as the DEPIC2 will convert the linear position reading to angular rotary position.

Linear: For linear actuators, it should be selected as linear as the DEPIC2 will compensate non-linearity for linear magnets

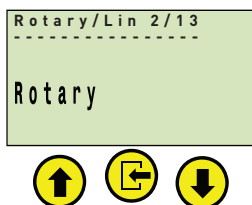

5.5 The LCD will display following screen to configure the DEPIC-2 for the fail mode. Use the up/down arrow key to change the selection between "Fail Closed" and "Fail Open". Press the Select key to accept the current selection.

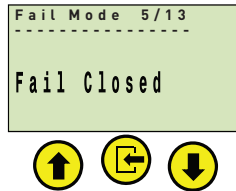

Fail Closed: select this setting if the valve moves towards fully closed position when the solenoid is de-energized.

Fail Open: select this setting if the valve moves towards fully open position when the solenoid is de-energized.

5.6 The LCD will display following screen to configure the DEPIC-2 for the device control mode. Use the up/down arrow key to change the selection between "Enable" and "Disable". Press the Select key to accept the current selection.

Enable: if device control is enabled, the DEPIC will move the valve automatically to perform certain actions like auto calibration and auto full stroke signatures.

Disable: if device control is disabled, the DEPIC will not move the valve automatically to perform certain actions like auto calibration and auto full stroke signature. In this case the user can use the manual calibration and dynamic baseline features to configure the device, however the valve is required to be moved manually to the correct position during manual calibration.

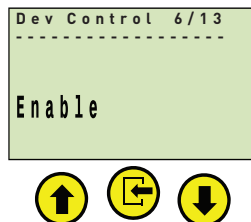

DEPIC 2 HART POSITION TRANSMITTER - MODELS D510 AND D520

INSTALLATION AND OPERATIONS MANUAL

5.7 The LCD will display the following screen to configure the DEPIC-2 for the ESD monitoring. Use the up/down arrow key to change the selection between "Enable" and "Disable". Press the Select key to accept the current selection.

Enable: Emergency Shut Down monitoring is enabled. The DEPIC-2 will generate an alarm when the solenoid is de-energized. The ESD alarm should be enabled separately in the basic configuration for the DEPIC-2 to generate an alarm.

Disable: Emergency Shut Down monitoring is disabled. The DEPIC-2 will not generate an alarm when the solenoid is de-energized.

NOTES

The factory option "ESD" must be enabled to have this setting available for the user.

The user must have purchased a DEPIC-2 model that has the ESD monitoring feature.

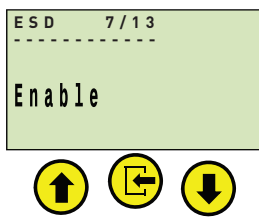

5.8 The LCD will display the following screen to configure the DEPIC-2 for the pressure sensor-1 operation. Use the up/down arrow key to change the selection between "Enable" and "Disable". Press the Select key to accept the current selection.

Enable: Pressure sensor-1 is enabled. The DEPIC-2 will assume the current model is equipped with the pressure sensor-1 and is pneumatically connected to the actuator chamber. It will show all pressure-1 related hysteresis and alarm settings in the full menu later on. The user must have purchased a DEPIC-2 model that has the pressure sensor-1.

Disable: Pressure sensor-1 is disabled. The DEPIC-2 will assume the current model is NOT equipped with the pressure sensor-1 or it is not pneumatically connected to the actuator chamber. It will hide all pressure-1 related hysteresis and alarm settings in the full menu later on.

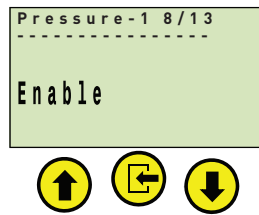

5.9 The following setting is dependent on the pressure sensor-1 configuration. If the user has disabled the pressure sensor-1 in the previous step, the DEPIC-2 will skip this step otherwise the LCD will display the following screen to configure the DEPIC-2 for the pressure sensor-2 operation. Use the up/down arrow key to change the selection between "Enable" and "Disable". Press the Select key to accept the current selection.

Enable: pressure sensor-2 is enabled. The DEPIC-2 will assume the current model is equipped with the pressure sensor-2 and is pneumatically connected. It will show all pressure-2 related hysteresis and alarm settings in the full menu later on. The user must have purchased a DEPIC-2 model that has the pressure sensor-2.

Disable: pressure sensor-2 is disabled. The DEPIC-2 will assume the current model is NOT equipped with the pressure sensor-2 or it is not pneumatically connected. It will hide all pressure-2 related hysteresis and alarm settings in the full menu later on.

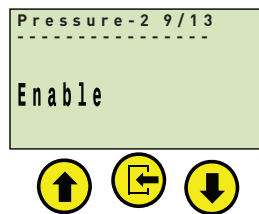

5.10 The following setting is dependent on the pressure sensor-2 configuration. If the user has disabled the pressure sensor-2 in the previous step, the DEPIC-2 will skip this step otherwise the LCD will display the following screen to configure the DEPIC-2 for the pressure sensor-2 usage. Use the up/down arrow key to change the selection between "Supply Pressure" and "Actuator Chamber Pressure". Press the Select key to accept the current selection.

Supply

Pressure:The DEPIC-2 will assume the pressure sensor-2 is pneumatically connected to monitor the supply pressure. It will show all pressure-2 related hysteresis and alarm settings in the full menu later on to monitor the supply pressure. The user must have purchased a DEPIC-2 model that has the pressure sensor-2.

Actuator

Pressure:The DEPIC-2 will assume the pressure sensor-2 is pneumatically connected to monitor the second chamber of the actuator. It will show all pressure-2 related hysteresis and alarm settings in the full menu later on to monitor the pressure in the second actuator chamber. The user must have purchased a DEPIC-2 model that has the pressure sensor-2.

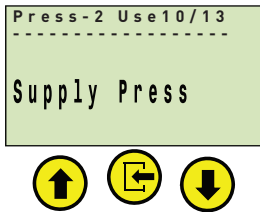

5.11 This step is dependent on the current clock configuration. If the DEPIC-2 has the valid time preconfigured from the factory, it might skip this step to configure the clock otherwise it will display the following screen to configure the clock on the device. Use the up/down arrow key and the select key to configure the date and time. The date must be configured in Month/Day/Year format and the time must be configured in Hours: Minutes in 24 hours format.

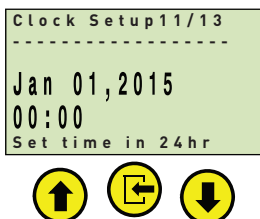

5.12 This step is dependent on the setting "Device Control" configured in the previous step. If the user has disabled the "Device Control" in the previous step, the DEPIC-2 will display the screen to run the manual calibration. If the user has enabled the "Device Control" setting in the previous step, the DEPIC- 2 will display screen to run the auto calibration. Use the up/down arrow key to change the selection between "Yes" and "No". Press the Select key to accept the current selection.

NOTE

If 'AUTO CALIBRATION' has been selected, please ensure that the correct pneumatic (see Section 3.1 and 3.2)/ electrical connections (see Figure 4.1) have been made and are turned on and the solenoid voltage connections have been made.

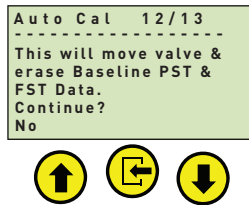

6 USER INTERFACE

6.1 The DEPIC2 position transmitter has both an on-board keypad/LCD menu structure and/or a HART menu structure that can be accessed by pressing the Select button or from the Main Menu of a HART host. Exit any function by pressing the up arrow button to back out of any keypad menu or the back arrow on the 475.

6.2 The basis of the menu systems of the DEPIC2 were developed with a HART DD and are emulated by the Push Button/ LCD menu system so once someone gets used to using one interface, it becomes easy to navigate the other interface. See the following sections on Configuring and Calibrating the DEPIC2. While the menus shown below more closely illustrate the Push Button/LCD, the HART DD menus are very similar if not identical.

6.3 From the keypad/LCD interface, if the device is not configured when first powered up, it will ask the user to run the setup wizard when the user tries to access the menu screen. If the user selects to run the setup wizard, it will ask the user to configure some basic settings step by step and perform the calibration. The setup wizard is only available using keypad/LCD not on the HART DD.

7 CONFIGURATION

7.1 First the device must have some basic configuration set up. As a Quick Start, this will cover some very basic configuration for basic functionality. For more complex configurations, see the full IOM. Figure 7.1 shows the Configuration menus to perform a basic configuration.

Figure 7-1 - Configuration Menu

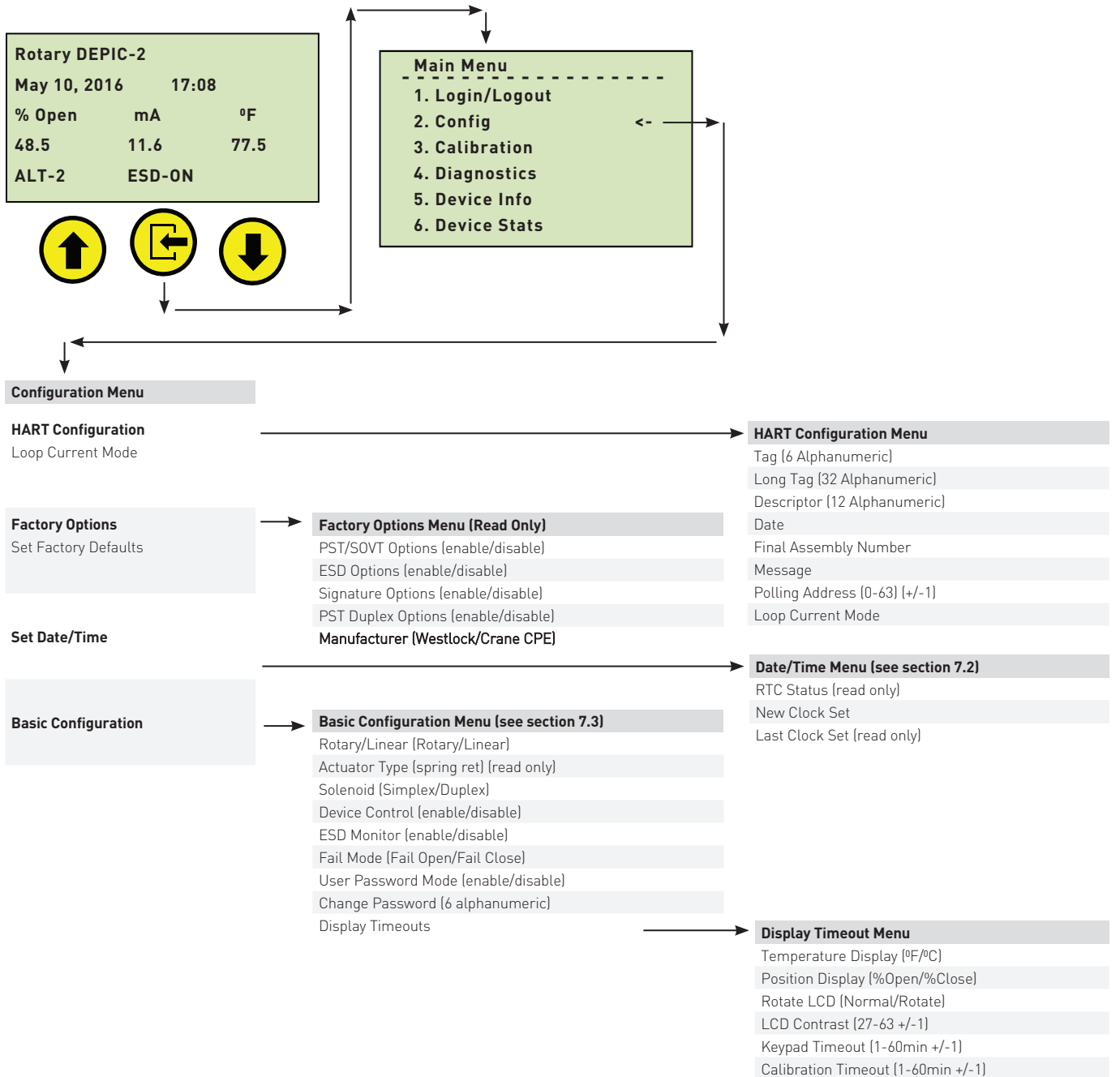

Continued On Next Page

DEPIC 2 HART POSITION TRANSMITTER - MODELS D510 AND D520

INSTALLATION AND OPERATIONS MANUAL

Configuration Menu (continued)

PST Configuration



Partial Stroke Configuration Menu

- PST Mode (enable/disable PST)
- PST Travel Limit (0-50% +/-0.1%)
- PST Travel Limit Error (0-50%)
- PST Fail Limits
- Cycle Limits (0-65535 +/-1)
- PST Discrete I/O (enable/disable)
- PST Count (0-65535 +/-1)
- Auto PST



PST Fail Limits

- PST Break Pressure Hyst (0-20% +/-1)
- PST Travel Time Hyst (0-20% +/-1)
- PST Total Time Limit (0-600s +/-0.1s)



Auto PST Menu

- Auto Mode (enable/disable)
- Auto PST Day (0-365 days +/-1)
- Auto PST Hour (0-24 hour +/-1)

SOVT Configuration



SOVT Configure Menu

- Auto Mode (enable/disable)
- Auto SOVT Day (0-365 days +/-1)
- Auto SOVT Hour (0-24 hour +/-1)

Signature Configuration



Signature Menu (see section 7.4)

- Signature Mode (enable/disable)
- Pressure Sensor-2 (enable/disable)
- Pressure Sensor-2 Usage (Supply/Actuator Chamber)
- Dynamic Baseline (0-255 Cycle +/-1)

Alert Hysteresis Configuration



Alert Hysteresis Menu

- Open Time (0-50% +/-0.1)
- Close Time (0-50% +/-0.1)
- Open Position (0-50% +/-0.1)
- Close Position (0-50% +/-0.1)
- Pressure-1 (0-50% +/-0.1)
- Pressure-2 (0-50% +/-0.1)

Service/Maintenance



Service/Maintenance Menu

- Service Interval (0-365 +/-1)
- Last Service Date
- Last Service Time
- Next Service Date
- Next Service Time

Alert Configuration



Error Alert (enable/disable)

- Alarm Alert (enable/disable)
- Service Alert (enable/disable)
- Cycle Alert
- ESD Alert (enable/disable)
- PST Alerts (enable/disable)



Cycle Alarm Menu

- Cycle Count
- Cycle Limit
- Cycle Alarm (enable/disable)



PST Alarms Menu

- Invalid Position (enable/disable)
- Solenoid Fail (enable/disable)
- Exceed STTL (enable/disable)
- Exceed FTTL (enable/disable)
- Exceed LBPL (enable/disable)
- Exceed HBPL (enable/disable)
- Exceed TTL (enable/disable)

7.2 The first configuration to be set up is the Date/Time. So from the Configuration menu select Set Date/time (Date/Time Set-up on HART), then select New Clock Set (Set New Date/Time from HART), then set the date/time according to your location.

- 7.3** Next from Configuration menu select Basic Configuration and set the following parameters:
- Rotary/Linear - based upon type of actuator and magnet assembly.
 - Solenoid (Simplex/Duplex) - Generally Simplex is selected unless a redundant solenoid is used.
 - Device Control - Enable if it is desired to let the device control the valve for Calibration and Diagnostics.
 - ESD Monitor - If Factory Option is enabled, enable if Emergency Shut-Down (ESD) monitoring is desired.
 - Fail Mode - Select Fail-Closed or Fail-Open depending upon the type of spring-return actuator used.

- 7.4** Next from Configuration menu select Signature Configuration and set the following parameters:
- Signature Mode - If Factory Option is enabled, enable or disable depending if Full-Stroke and Partial-Stroke Signatures are desired.
 - Pressure Sensor 2 - Enable if the second Pressure sensor is desired
 - Pressure Sensor 2 Usage - Only if Sensor 2 is enabled, Sensor 2 can be Supply Pressure or second chamber of actuator (usually for double-acting, future).
- Next from Configuration menu select PST Configuration and set the following parameters:
- PST Mode - If Factory Option is enabled, enable or disable PST as desired.

8 CALIBRATION

8.1 Next the device must be calibrated assuming no other complexity in the Configuration is desired from the IOM. As a Quick Start, this will cover the full calibration for this basic functionality. For more complex calibrations, see the full IOM. Figure 8-1 shows the Calibration menus to perform a full calibration (primarily of the position sensor and the pressure sensors if used).

Figure 8-1 - Calibration Menu

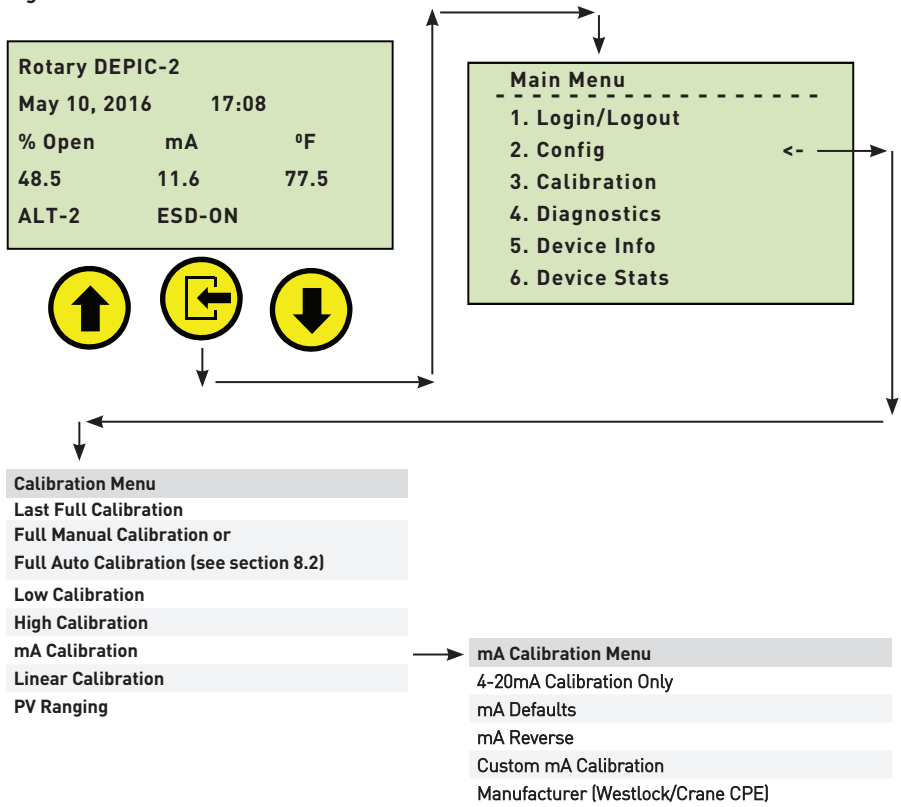

DEPIC 2 HART POSITION TRANSMITTER - MODELS D510 AND D520

INSTALLATION AND OPERATIONS MANUAL

8.2 From the main menu (LCD or HART), select Calibration. Then select either Full Manual Calibration (Full User Controlled Calibration from HART) or Full Auto Calibration (Full Device Controlled Calibration from HART), one or the other is visible depending upon the Device Control configuration set earlier. If Device Controlled Calibration is enabled, there is no user intervention, the device will move the valve as needed to perform the calibration and once completed, an indication will be provided if there was a failure. If User Controlled Calibration is used, there will be instructions displayed on the LCD or from HART to guide through the steps required, and once completed, an indication will be provided if there was a failure.

Note

A message appears; 'This will move valve & erase Baseline PST & FST Data. Continue? No/Yes' Use UP/DOWN arrow keys to display 'YES' then press the 

CALIBRATION SCREENS

NOTES

The presentage shown on screens is the percentage of the total calibration process that has been completed so far. Baseline Partical Stroke Test and Full stroke Test signatures are based on calibration values so that they must be repeated after a new callibration is done

8.3 After completing the Full Calibration, the output current will be set for 4 mA for closed position and 20 mA for the open position. This current may not be exact but will be close. If desired to calibrate the output current to the exact value or to change the current values for open/closed positions, the mA Calibration menu must be used. See the full IOM for instructions on mA Calibration.
Also see the IOM for use of HART PV (Primary Variable) Ranging.

Full auto calibration

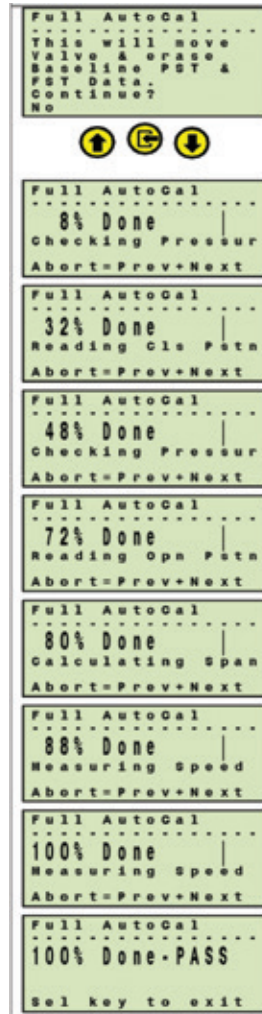

Use up and down arrows to change "No" to "Yes", then press Select

Full manual calibration

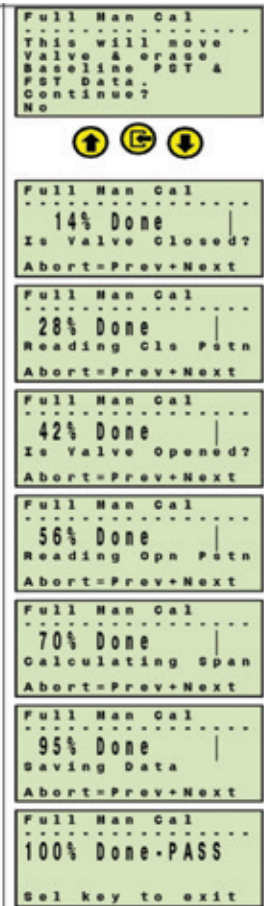

Use up and down arrows to change "No" to "Yes", then press Select

Close the valve then press Select

Open the valve then press Select

DEPIC 2 HART POSITION TRANSMITTER - MODELS D510 AND D520

INSTALLATION AND OPERATIONS MANUAL

APPENDIX A

Field Wiring and Grounding Schematic

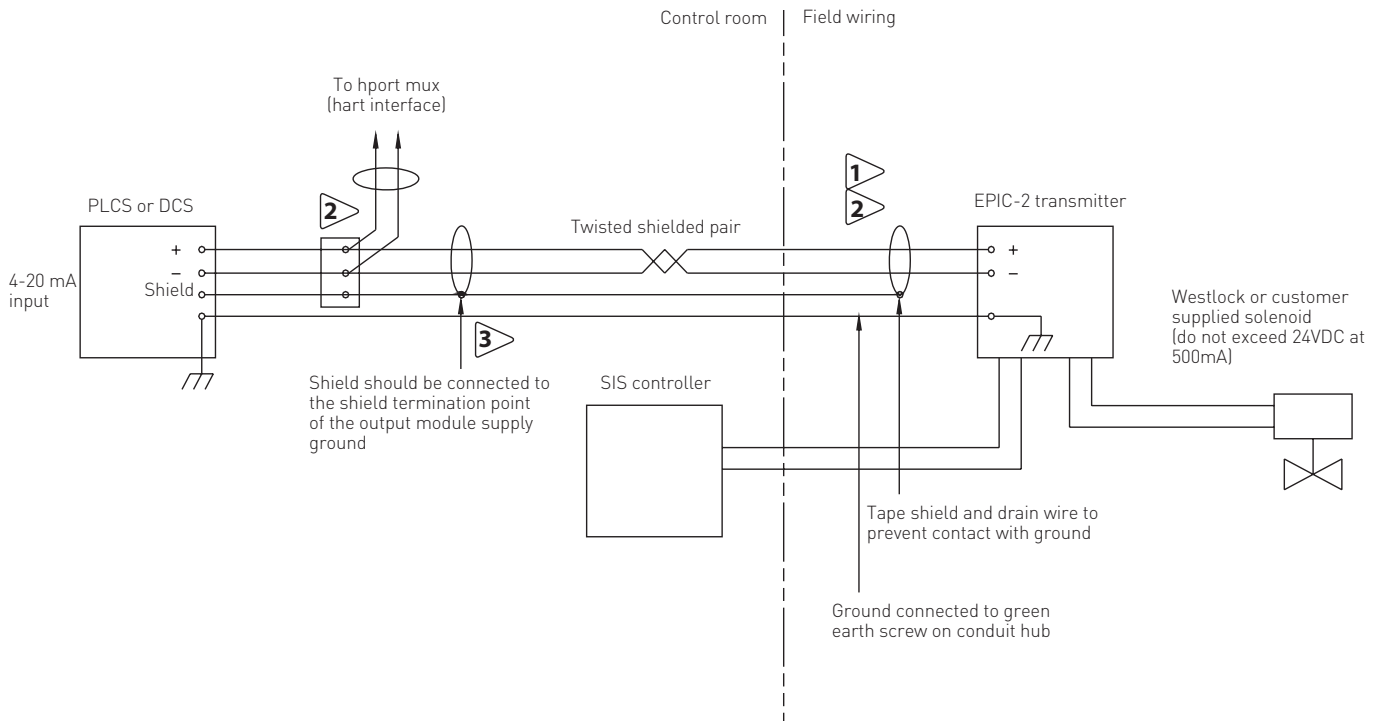

NOTES

1. Connection from DCS or PLC to transmitter is 20 gauge shielded twisted pair (belden 8762 or equivalent). Maximum distance is 5000 feet
2. Connection from hart multiplexer to transmitter is 20 gauge shield twisted pair (belden 8762 or equivalent). Maximum distance from hart multiplexer to positioner is 6000 feet
3. Shield shall be connected to ground at one point only in order to avoid ground loops and noise interference
4. The following table per IEEE STD 518-1982 indicates the minimum distance between cable trays and conduits containing level 1 (this includes 4-20 mA signals and 120VAC or 480 VAC, in order to minimize electrical noise interference.
5. field wiring to be in compliance with the nec and cec for ni equipment in class 1 division 2.)

Raceway	480 VAC	120 VAC
Tray	26"	6"
Tray-conduit	18"	4"
Conduit	12"	3"

APPENDIX B

Enclosure Cover Lock Operation

To maintain approval compliance, the cover lock is required to be used to set. The cover lock employs an Allen Head Cap Screw to secure to the underside of the cover when turned in the CCW direction.

Both covers (large and small) use the same cover lock design. See figure below for reference.

1. For large cover use a $\frac{5}{32}$ (.155") or 4mm A/F Allen key and for the small cover use a $\frac{9}{64}$ (.141") Allen key. Turning in a CCW direction to engage the screw.
2. Tighten to 12 in · lbs. (1.35 Nm).

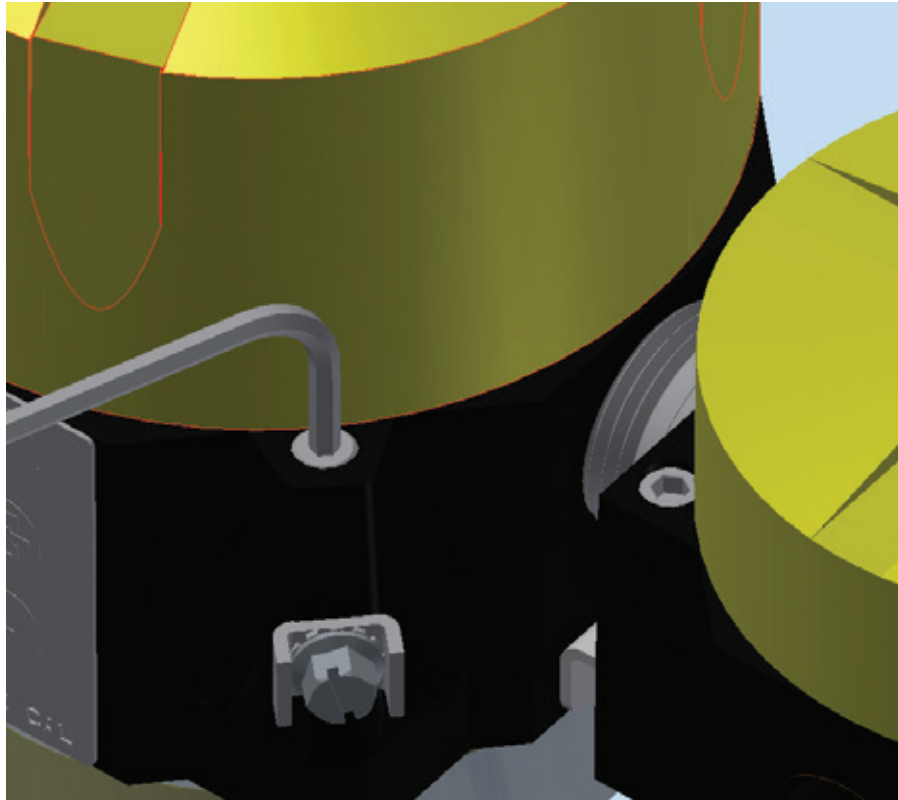

ENGINEERING DOCUMENT REFERENCE

These installation and operating instructions are based on the latest engineering update, and form part of the certification for the D510/520 DEPIC-2 series. To ensure you have the most recent version of this IOM, please check the document library on our website (westlockcontrols.com).

TRANSLATIONS

Where translated the copy is taken from the original English document VCIOM-04592-EN as checked by the relevant notified certification body and therefore the original English document will prevail. No rights or liability can be derived from any translation.

PREVIOUS DOCUMENTS

VCIOM-04592 replaces all previous installation and operating instructions for the D510/520 including TECH-491Q



WARNING

This symbol warns the user of possible danger. Failure to observe this warning may lead to personal injury or death and/or severe damage to equipment.



ATTENTION

This symbol identifies information about operating the equipment in a particular manner that may damage it or result in a system failure. Failure to observe this warning can lead to total failure of the equipment or any other connected equipment.



NOTE

This symbol draws attention to information that is essential for understanding the operation and/or features of the equipment.