

ACCUTRAK ROTARY MODELS 1040/9358/2004/9044/9468/5004/5044/360/366/2007/9479
INSTALLATION AND OPERATING INSTRUCTIONS

Installation and operating instructions for Westlock AccuTrak position monitor rotary models.

1 INTRODUCTION

1.1 Product Certification

General Purpose	Non-incendive	
<p>1040/9358: Type 4 - CSA: 1185829 (LR 81057-3) 2004: Type 4, 4X - CSA: 2599677 (LR 81057-1) 9044: Type 4, 4X - CSA: 2599677 (LR 81057-1)</p>	<p>9468: Non-incendive, Cl. I, Div. 2 Grps A, B, C, D; 4 Ta = -30°C to +60°C; Cl. II, Div. 2, Grps F & G; T4 Ta = -30°C to +60°C Type 4X, 6P, IP67 FM19CA0064 FM19US5121</p>	
Intrinsically Safe	Explosionproof/Flameproof	
<p>5004/5044: Cl. I, II, III, Div. 1, Grps. A, B, C, D, E, F, G; Cl. III; T6 Ta=60°C; Type 4X, Entity WD-11880, Non-incendive, Cl. I, Div. 2, Grps A, B, C, D; T6 Ta=60°C, Type 4X, Entity WD-11880; Entity Parameters for P&F: NJ2-V3-N, Vmax=16 V, Imax=25 mA, Pi=34 mW, Ci=40 nF, Li=50 µH; NJ2-11-N-G, Vmax=16 V, Ii=25 mA, Pi=34 mW, Ci=30 nF, Li=50 µH FM18CA0137X FM18US0286X</p>	<p>360/366: Intertek ATM: 104050146CRT-001 Cl. I, Div. 1, Grps A¹, B, C, D; T*; Cl. II/III, Div. 1, Grps E, F, G; T*; Non-incendive, Cl. I, Div. 2, Grps A, B, C, D; T*; Type 4, 4X; 6P Ta = -60°C to +65°C (T6/80°C)/-60°C to +80°C (T5/95°C)/-60°C to +110°C (T4/130°C) Ta = -40°C to +85°C (T4/130°C); when fitted with DS transmitter W/ SOL. EDPM: Ta = -55°C to +60°C (T4/130°C); W/ SOL. LT BUNA: -40°C to 52°C (T4/130°C); W/ SOL. BUNA: -20°C to +60°C (T4/130°C) ¹Solenoid not available with Group A. 2007/9479: Intertek ATM: 103627517CRT-001 Cl. I, Div. 1, Grps C, D, T*; Cl. II, Div. 1, Grps E, F, G, T*; Type 4, 4X; IP66/67 Aluminum: Ta = -50°C to +60°C (T6/80°C) Ta = -50°C to +75°C (T5/95°C) Ta = -50°C to +110°C (T4/130°C) Stainless Steel: Ta = -70°C to +60°C (T6/80°C) Ta = -70°C to +75°C (T5/95°C) Ta = -70°C to +110°C (T4/130°C)</p>	<p>E2007/E9479: Intertek ATM: 103627517CRT-001 Cl. I, Div. 1, Grps C, D, T*; Cl. II, Div. 1, Grps E, F, G, T*; Type 4, 4X; IP66/67; W/ EPDM: Ta = -50°C to +60°C (T4/130°C) Alum. Enclosure Only; W/ EPDM: Ta = -55°C to +60°C (T4/130°C) ST ST Enclosure Only; W/ LT BUNA: -40°C to +52°C (T4/130°C); W/ BUNA: -20°C to +60°C (T4/130°C) II 2 G Ex db IIB+H2 T* Gb Ta = -°C to +°C II 2 D Ex td IIIC T* Db Ta = -°C to +°C ITS12ATEX17472X IECEx ETL 17.0008X *Ambient temperature depend on configuration, see product certificate for details.</p>



1.2 Warnings

- Never remove enclosure cover or make/break electrical connections with power connected to the unit.
- Perform all wiring in accordance with site and local codes and the National Electric Code Part I (Canada) for the appropriate area classification.
- Confirm that the AccuTrak model being installed is approved for the hazardous area [see Product Certification section above and unit ID label.]
- Confirm that supply power to switches is within rated specifications listed on the unit identification label.
- Protect the unit from exposure to aggressive substances or atmospheres to ensure that hazard rating is not compromised.

- It is the responsibility of the customer to verify whether the unit model being installed bears a SIL approval for use in safety systems before installing it in safety applications.

1.3 Description

AccuTrak valve position monitors are intended for use as both visual and electrical position indicators for discrete rotary devices, most commonly pneumatically actuated 2-way quarter-turn or 3-way valves. An AccuTrak monitor is not limited for use in only quarter-turn valve applications, but that application will be assumed for the purpose of this document. In addition to the monitoring features, AccuTrak monitors may serve as wiring junction for accessories where additional terminals, conduit entries and codes permit.

1.4 Principles of Operation

An AccuTrak monitor mounts to an actuator via a mounting kit, usually sold separately. The unit shaft couples to the actuator shaft directly via NAMUR adaptation, or via a coupling provided in the mounting kit. As the actuator rotates the unit shaft, adjustable cams on the shaft actuate mechanical or proximity switches inside the unit enclosure, at the limits of rotary travel set by the customer. The switches are pre-wired to a terminal strip in the enclosure, permitting easy connection of switch output to external electrical monitoring systems or indication devices. The visual Beacon indicator on the enclosure cover indicates 90° rotary travel between OPEN and CLOSED valve position, unless ordered optionally for other angular strokes or 3-way valve applications.

ACCUTRAK ROTARY MODELS 1040/9358/2004/9044/9468/5004/5044/360/366/2007/9479

INSTALLATION AND OPERATING INSTRUCTIONS

FIGURE 1

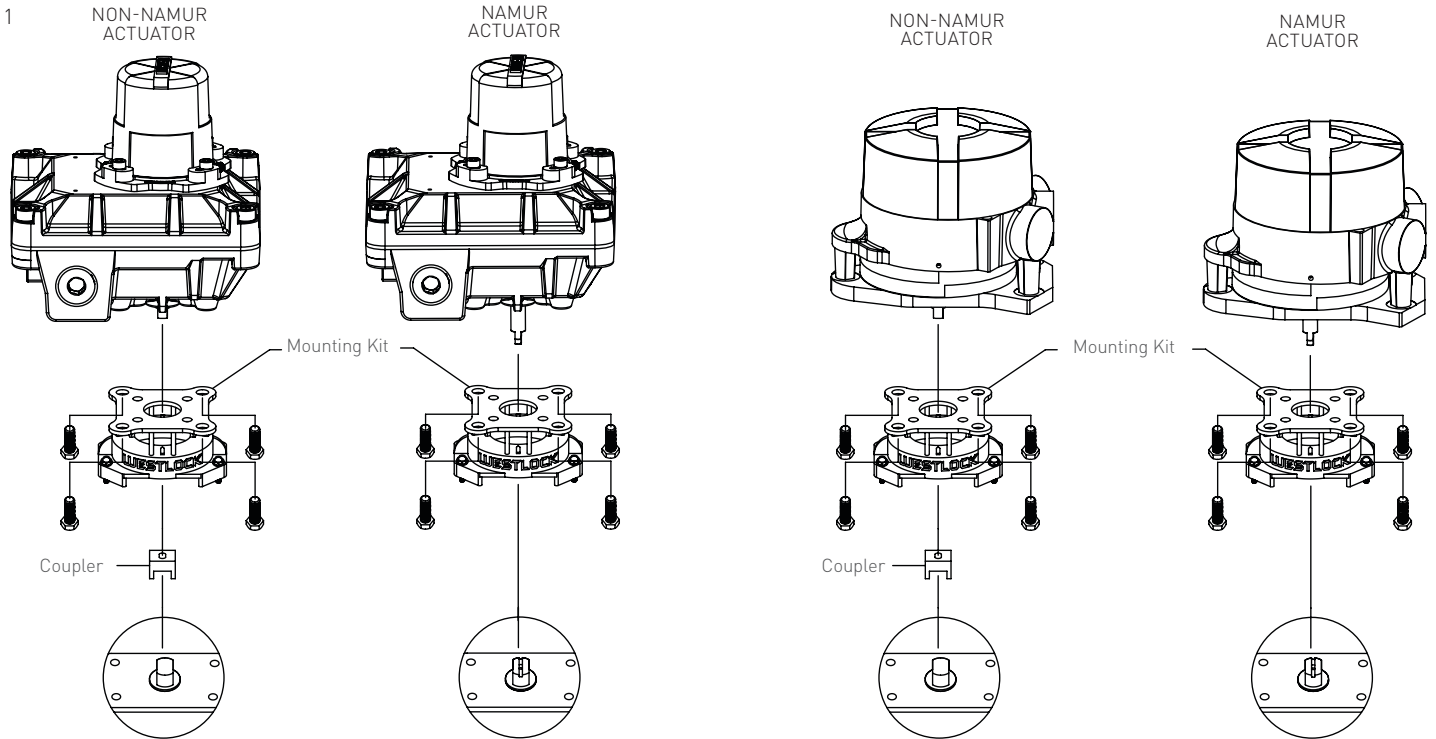

1.5 Special Features/Conditions

To avoid build-up and discharge of static electricity in a hazardous area, only clean Westlock units with static-free cloth dampened with water. Never use solvent-based cleaners.

2 ORDERING

Ordering guides for all AccuTrak product series covered by this IOM are available through a local Westlock distributor, the current Westlock Controls catalog literature or the Westlock Controls website at www.westlockcontrols.com. Spare parts lists for refurbishments or repairs are also available for common AccuTrak models.

3 DEFINITIONS

NAMUR - This term, in the context of mounting brackets and shafts, refer to the NAMUR VDI/VDE 3845 standard for the dimensions of actuator output shafts and auxiliary equipment mounting hole pattern. In the context of inductive proximity sensors, NAMUR refers to the conformance of the sensor to DIN 19 234, allowing its use with any NAMUR style amplifier/isolator.

Switch - A manual or mechanically actuated device for making, breaking or changing the connections in an electric circuit. This term will be used also for the magnetic or inductive proximity sensors for the purpose of this document.

4 INSTALLATION

4.1 Mounting instructions

Required tools: open-end wrenches or adjustable wrench to fit all sizes of hex head bolts in the mounting kit.

1. Obtain a mounting kit suited for the actuator/valve, commonly available through a Westlock Controls distributor.
2. Attach the mounting bracket and coupler (if required) to the unit housing with the hardware provided.
3. Attach the unit and mounting system to the actuator.
4. If mounting kit includes coupler, ensure proper axial alignment between unit shaft, coupler and actuator shaft. Failure to ensure this alignment could result in long-term stress-related failure of the unit shaft in high cycle or high torque applications.

4.2 Calibration



Note 1: Switch actuation can be confirmed using a signal detection device such as a multimeter or ohmmeter, set for "continuity".



Note 2: For NAMUR P+F NJ2-V3-N type sensors, use test meter, P+F model #1-1350 or equivalent to check sensor actuation and calibration. If the proper meter is not available, contact the factory for additional assistance with the test procedure.



Note 3: Adjust cams by hand by pushing/pulling the cam against the shaft spring to disengage from the mating spline, rotating to adjust and reengaging firmly onto spline.

Required tools: Signal detection device (see note 1); slotted screw driver/hex (Allen) key for cover screws (M4, M5 or M8 by model)

Switch adjustment (two switches)

1. Remove unit cover as follows: loosen (but do not remove) captive screws, rotate cover slightly to grip corners, pull firmly. DO NOT PRY COVER WITH TOOLS.
2. With valve in the closed position, adjust bottom cam until bottom switch (#2) actuates.
3. Stroke valve to the open position, adjust top cam until top switch (#1) actuates.
4. Cycle actuator several times to confirm proper switch indication at each end of stroke. Finely adjust cams if necessary.
5. Skip to Field Wiring section or replace unit cover, applying approximately 20 in.-lbs of torque to cover screws.

FIGURE 2

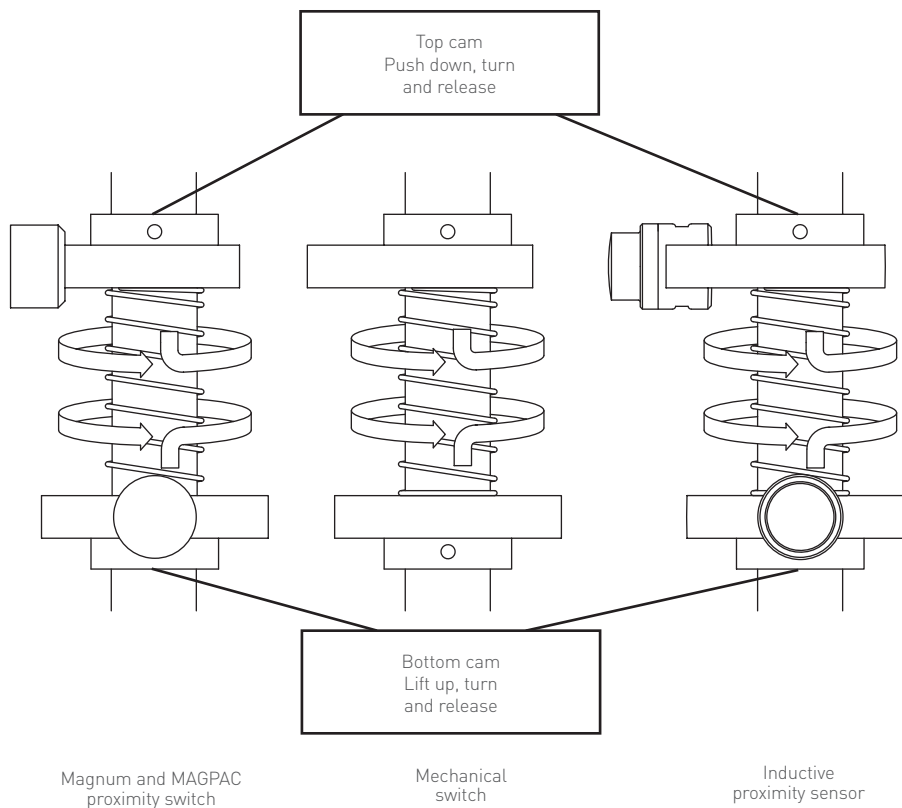

Switch adjustment (four switches, no DS/CS transmitter option)

Follow the steps as above for the calibration of two switches but adjust the first and third cams from the top for switches #1 and #2 and the second and fourth cams from the top for switches #3 and #4 (see Figure 3).

FIGURE 3

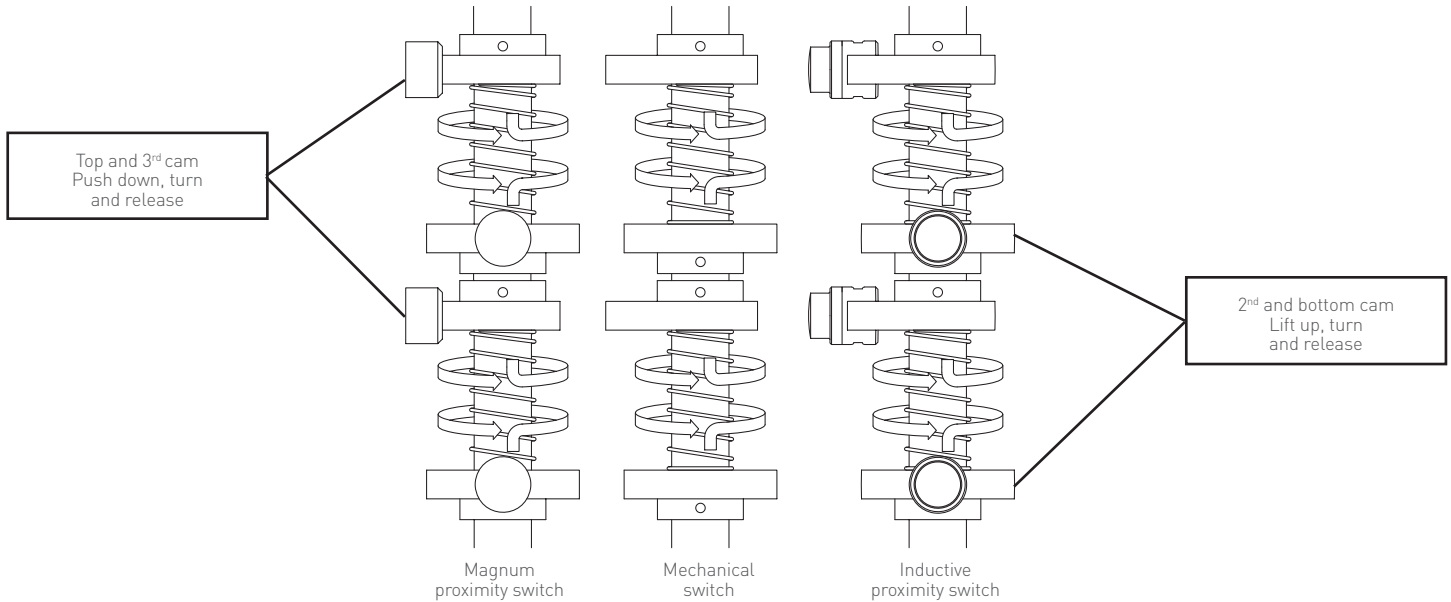

Transmitter setting (optional DS/CS transmitter)

For calibration of the optional digital signal (DS), see Westlock Controls Installation/Operations Manual TECH-541. For the calibration of optional current signal (CS), see VCIOM-04112. VCIOM-04112 and TECH-541 is available through your local sales representative or at www.westlockcontrols.com.

Beacon adjustment



Note: Skip this step if the cover is flat or Beacon already displays the correct valve status.

Required tools: slotted screw driver for #12 screws/hex (Allen) key for M5 socket head screws.

1. For two-way OPEN/CLOSED: remove, rotate and re-fasten outer Beacon to synchronize display position with valve position. See figure 4.
2. For three-way flow paths: remove, rotate and re-fasten outer Beacon and/or inner Beacon coupler to synchronize displayed flow path with valve/actuator flow path.

FIGURE 4

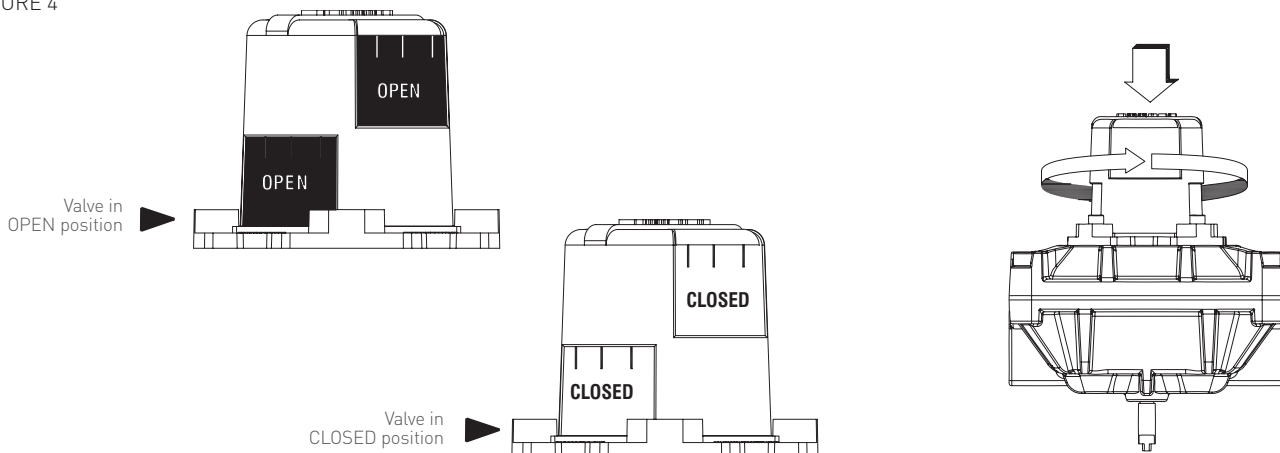

ACCUTRAK ROTARY MODELS 1040/9358/2004/9044/9468/5004/5044/360/366/2007/9479

INSTALLATION AND OPERATING INSTRUCTIONS

Beacon adjustment for 360/366



Note: Skip this step if the cover is flat or Beacon already displays the correct valve status.

Required Tools: set screw driver for M4 set screws and snap ring tool.

1. Disengage set screws from outer beacon, rotate and re-fasten outer beacon to synchronize displayed position with valve position.

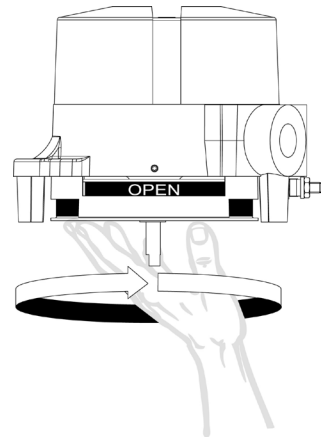
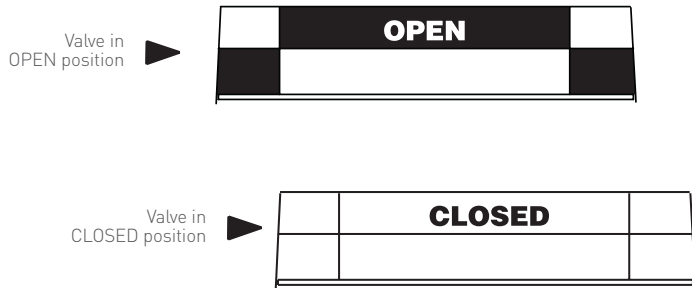

THREE WAY VALVE BEACON INDICATION (WHEN SPECIFIED) STANDARD FLOW ARRANGEMENTS

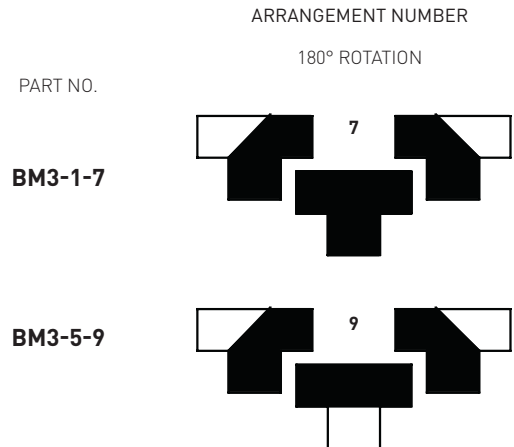
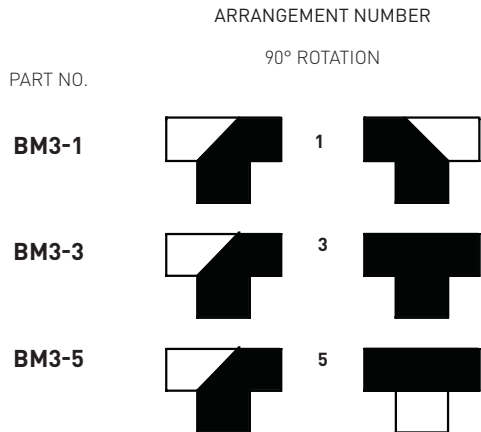

5 FIELD WIRING



WARNING

See the warnings section of this document for important warnings pertaining to the wiring of this unit. Remove and replace cover before and after wiring

Required tools: slotted screw drivers for terminal strip screws (#2), cover screws (M4, M5 or M8 by model), and grounding screw (#8 or M5 by model); wire strippers as required for field wires.

1. Wire the AccuTrak monitor strictly according to the wiring diagram on the inside of the enclosure cover.
2. Confirm that the ground wire is secure under the grounding screw in the enclosure.
3. Seal all unused conduit entries as required with suitably certified and rated plugs having an ingress protection rating of IP67 or better.
4. Ensure that only suitably certified and rated cable glands are used, having an ingress protection rating of IP67 or better.
5. Ensure that the temperature rating of all field wiring meets the service temperature range of the application.

DOCUMENT HISTORY

IOM: TECH-549
Rev: A
ECN #: 13470

RELEASE DATES

Initial release: 11/22/19
Rev A: 02/05/2020

Previous documents

This document replaces all previous installation and operating instructions including TECH-385, TECH-385Q and TECH-386.

Engineering document reference

These installation and operating instructions are based on the latest engineering update, reference ECN#13470, and form part of the certification for the AccuTrak series. To ensure you have the most recent version of this IOM, please check the document library on our website (westlockcontrols.com) to ensure this document has the latest ECN number.

Translations

Where translated the copy is taken from the original English document TECH-549-EN as checked by the relevant notified certification body and therefore the original English document will prevail. No rights or liability can be derived from any translation.

Crane Co., and its subsidiaries cannot accept responsibility for possible errors in catalogues, brochures, other printed materials, and website information. Crane Co. reserves the right to alter its products without notice, including products already on order provided that such alterations can be made without changes being necessary in specifications already agreed. All trademarks in this material are the property of Crane Co. or its subsidiaries. The Crane and Crane brands logotype (WESTLOCK CONTROLS®) are registered trademarks of Crane Co. All rights reserved.

WESTLOCK CONTROLS

Head Office
280 N. Midland Avenue, Ste. 258
Saddle Brook, NJ 07663
United States

USA
+1 201 794 7650

EUROPE
+44 (0)1892 516277

ASIA
+65 6266 4535



WARNING

This symbol warns the user of possible danger. Failure to observe this warning may lead to personal injury or death and/or severe damage to equipment.



ATTENTION

This symbol identifies information about operating the equipment in a particular manner that may damage it or result in a system failure. Failure to observe this warning can lead to total failure of the equipment or any other connected equipment.



NOTE

This symbol draws attention to information that is essential for understanding the operation and/or features of the equipment.