

Globe Control Valve Type 3241 (241)

Pneumatic Control Valves Type 3241/3271 (241-1) and Type 3241/3277 (241-7)

Application

Control valve for process engineering and plants with industrial requirements.

Nominal valve sizes ½" to 10" (15 to 250 mm)

Pressure ratings ANSI Class 125 to 300

Temperatures –320 °F to +800 °F (–196 °C to +427 °C)

The control valves consist of a body with trim, bonnet and pneumatic actuator, optionally with metal bellows or insulating extension. The valves may be also equipped with electric, electrohydraulic, or hand-operated actuators, as well as control accessories and other instrumentation.

Features

- Modular design, rugged and heavy duty construction, full range of body and trim materials
- One-piece ultra-rigid valve bonnet and yoke up to size 6"
- Field retrofitable extension bonnets and metal bellows seals
- Many configurations, e.g. Cryogenic or 'Lethal service'
- Self-adjusting, live-loaded PTFE V-ring stuffing box
- Port-guided V-port asymmetric plugs above Cv 20 standard
- Excellent dynamic response and high trim stability
- Self-locking seats, exchangeable for various Cv values
- Low height, reversible, multi-spring/rolling diaphragm actuator
- NAMUR (IEC 534-6) accessory mounting standard
- Complete selection of actuators options, positioners and control accessories

Standard versions – available combinations: see Table 1

- **Body** ASTM Cast A 126 Cl. B, A 216 WCB, A 351 CF8M, alternatively Forged A105 or A 182 F316
- **End connections** ANSI Class 125 with FF-Flanges, Class 250 Female threaded NPT, Class 150 or 300 with RF-Flanges
- **Packing** PTFE V-ring spring-loaded/self-adjusting, temperature range 15 °F to 430 °F (–10 °C to +220 °C)
- **Trim** equal percentage characteristic, metal-to-metal seal

Options

- **Body materials** · optionally A 352 LCB, LC3, A 351 CF8, CF3, Hastelloy, Monel, and others · On request
- **Packing** · Adjustable PTFE, graphite or others · On request
- **Extension bonnet module** · For extreme temperatures –328 to +842 °F (–200 to +450 °C) with PTFE packing
- **Metal bellows seal module** · For complete seal between process and atmosphere, with test connection and PTFE packing
- **Characteristic** · Linear (quick-opening on request)
- **Trim materials** · Hardened, Hast. C, Monel, other versions
- **Plug seal** · PTFE soft seal or lapped-in metal seal
- **Flow dividers** · For noise reduction · See Tech. Data Sheet T 8081
- **Pressure-balanced version** · For high differential pressures
- **Heating jacket, double stuffing box, micro trim, versions for sour gas according to NACE** · On request

DIN Versions · See Data Sheet T 8015 · JIS · On request

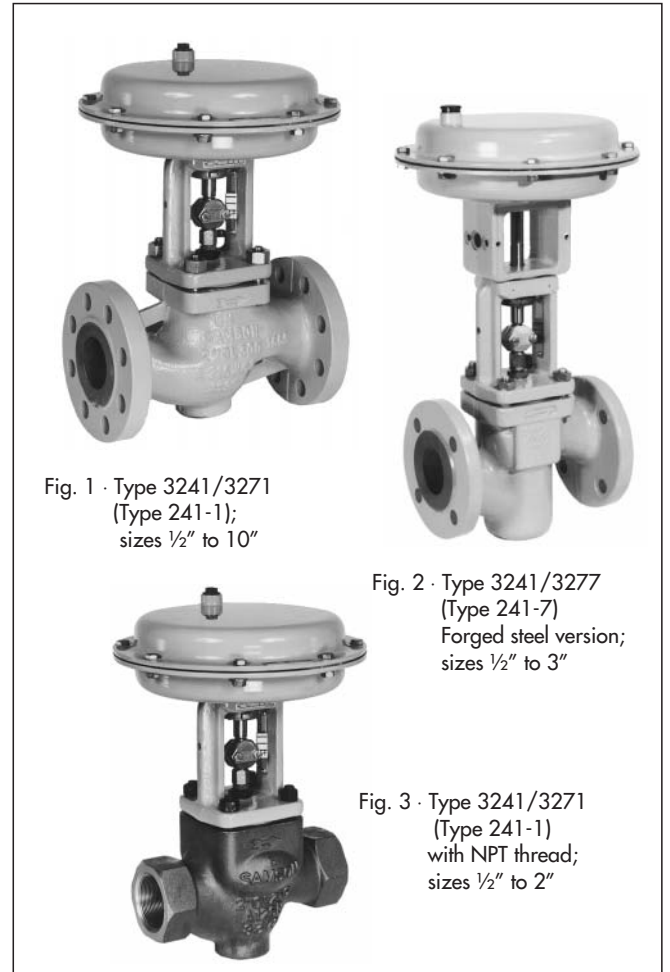

Fig. 1 · Type 3241/3271
(Type 241-1);
sizes ½" to 10"

Fig. 2 · Type 3241/3277
(Type 241-7)
Forged steel version;
sizes ½" to 3"

Fig. 3 · Type 3241/3271
(Type 241-1)
with NPT thread;
sizes ½" to 2"

Actuator combinations

- Type 3241/3271 (241-1) (Fig. 1) · With Type 271 Actuator (see T 8310)
- Type 3241/3277 (241-7) (Fig. 2) · With Type 3277 Actuator for integral positioner attachment (see T 8311)
- Type 3241/3273 (241-3) · With Type 3273 (273) Hand-operated Actuator (see T 8312)
- Type 3241/3274 (241-4) · With Type 3274 Electrohydraulic Actuator (see T 8340)

Fail-safe action

Depending on the arrangement of the diaphragm plate and springs within the actuator, the control valve offers two different fail-safe actions upon loss of air supply (see Technical Data Sheets T 8310 and T8311 for details):

Actuator "extends" stem (fail-close)

The actuator springs close the valve upon loss of air supply.

Actuator "retracts" stem (fail-open)

The actuator springs open the valve upon loss of air supply.

Notes on the differential pressure tables 4a to 5d

The differential pressure tables listed have been prepared under the following conditions:

- Process medium flow directed against the closing direction of the valve plug (flow-to-open valve)
- Version with PTFE stuffing box
- With the maximum differential pressures specified, the leakage rates specified in Table 1 (ANSI/FCI - Class IV) are not exceeded.
- The differential pressure specified must not exceed the pressure rating (see Pressure-Temperature Diagram).
- For valve sizes $\frac{1}{2}$ " to 3" with actuators containing an effective diaphragm area of 700 cm² (108 in²), the maximum permissible supply pressure is 60 psi (4 bar).

For versions with metal bellows seal, soft-sealed plugs and $p_2 \neq 0$ psi (0 bar), consult SAMSON.

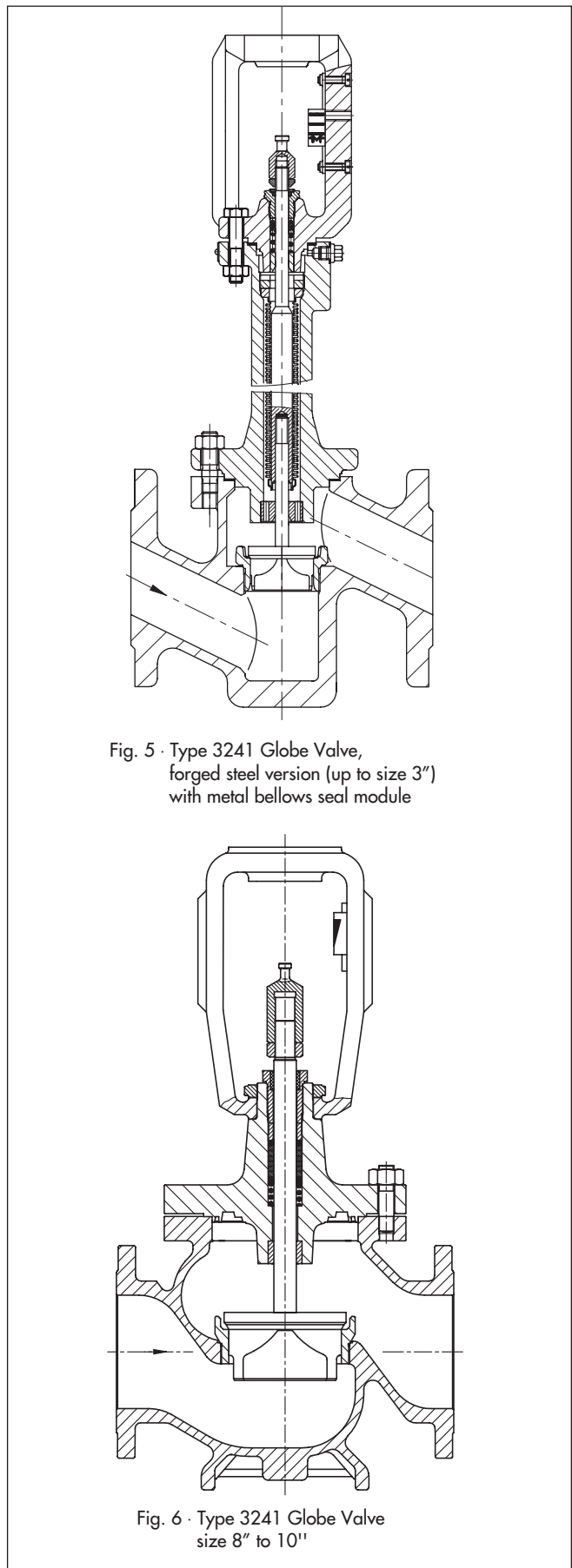
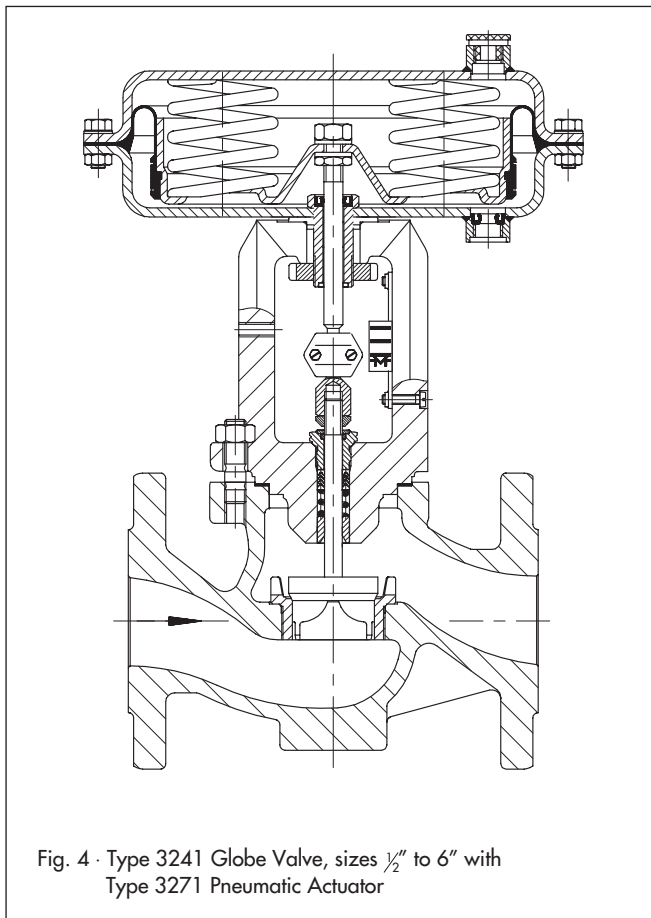

Table 1 · Technical data

| | | | | | | | |
|---|--------------------|--|--|---------------------------------|---------------------------------|-----------------------------------|------------------|
| Nominal valve size | in | 1 ... 6 | ½ ... 2 | ½ ... 10 | ½, 1, 1½, 2, 3 | ½ ... 10 | ½, 1, 1½, 2, 3 |
| Body material, ASTM (also see Table 2) | | A 126 Class B | | A 216 Grade WCB | A 105 | A 351 Grade CF8M | A 182 Grade F316 |
| End connection | | Flange | Thread | Flange | | Flange | |
| Form of connection | | Flat Face | NPT-F | Raised Face ¹⁾ | | Raised Face ¹⁾ | |
| Pressure rating, ANSI (B16.34) Class | | 125 | 250 | 150 or 300 | 300 | 150 or 300 | 300 |
| Face-to-face dimension | | According to ANSI/ISA S-75.03 (Flanges according to ASME/ANSI B16.5) | | | | | |
| Seat/plug seal | | Metal, soft or lapped-in metal | | | | | |
| Packing design | | V-ring, spring-loaded, self-adjusting | | | | | |
| Flow direction (standard) | | Flow to open (FTO) | | | | | |
| Seat bore diameter, rated travel, C _V /K _{VS} | | See Table 3 | | | | | |
| Characteristic | | Equal percentage or linear | | | | | |
| Terms for valve sizing according to ISA-S75.02 and IEC 60 534, parts 2-1 and 2-2 | | $F_L = 0.95, x_T = 0.75$ (at 75% rated travel) | | | | | |
| Rangeability | | 50:1 for sizes ½" ... 2" · 30:1 for sizes 2½" ... 10" | | | | | |
| Dimensions and Weights | | See Tables 7, 8 and 9 | | | | | |
| Temperature ranges °F (°C) · Max. operating pressures acc. to pressure-temperature diagram (see Information Sheet T 8000-2) | | | | | | | |
| Body without insulating section | | 15 ... 430 °F (-10 ... 220 °C) | | | | | |
| Body with | Insulating section | Short | -20 ... 445 °F (-29 ... 230 °C) | -20 ... 800 °F (-29 ... 427 °C) | -58 ... 800 °F (-50 ... 427 °C) | -325 ... 800 °F (-198 ... 427 °C) | |
| | | Long | - | - | - | -325 ... 800 °F (-198 ... 427 °C) | |
| | Bellows section | Short | -20 ... 445 °F (-29 ... 230 °C) | -20 ... 800 °F (-29 ... 427 °C) | -58 ... 800 °F (-50 ... 427 °C) | -325 ... 800 °F (-198 ... 427 °C) | |
| | | Long | - | - | - | -325 ... 800 °F (-198 ... 427 °C) | |
| Valve plug | Un-balanced | Metal sealing | -325 ... 840 °F (-196 ... 450 °C) | | | | |
| | | Soft sealing | -325 ... 428 °F (-196 ... 220 °C) | | | | |
| | Balanced | With PTFE ring | -325 ... 428 °F (-196 ... 220 °C) | | | | |
| | | With graph. ring | +430 ... 800 °F (+220 ... 450 °C) | | | | |
| Leakage rate class according to ANSI/FCI F70-2 (IEC 60 534 Part 4) | | | | | | | |
| Valve plug | Un-balanced | Metal seal | Class IV | | | | |
| | | PTFE soft sealed | Class VI | | | | |
| | | Lapped-in metal s. | Class VI (IEC: IV-S2 · For 4" or above, Class IV-S1) | | | | |
| | Balanced | Metal sealed | With PTFE balancing seal: Class IV · With graphite balancing seal: Class III | | | | |

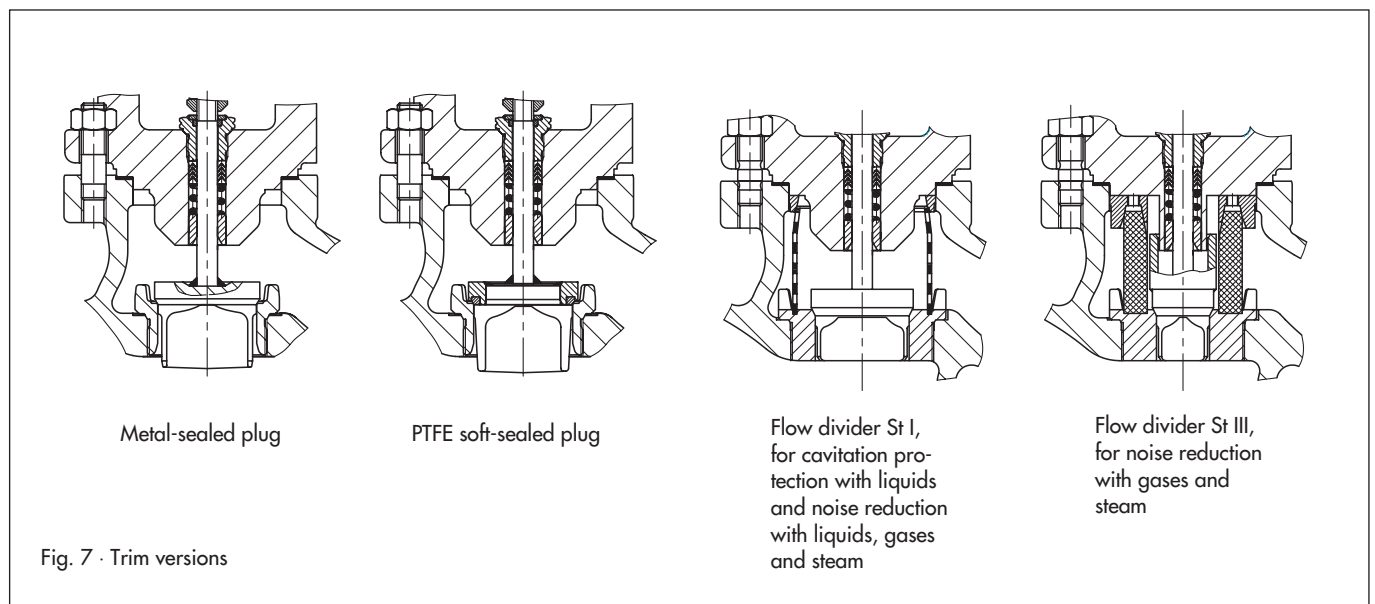

Fig. 8 · Type 3241 Globe Valve components

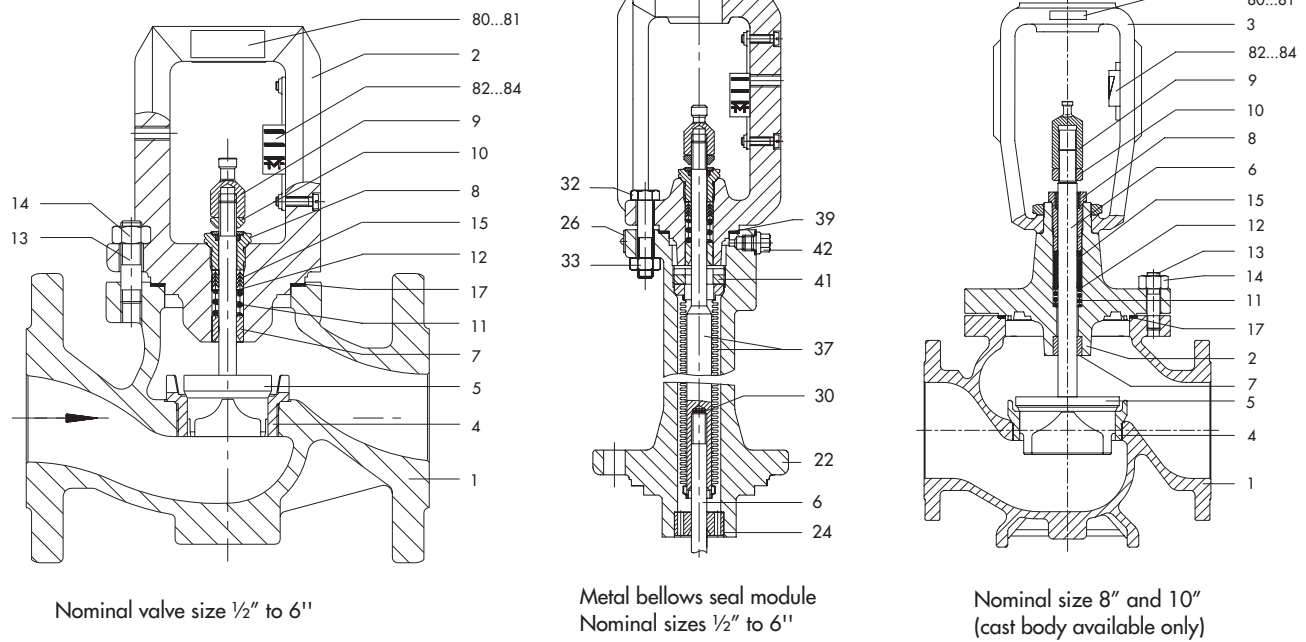

Table 2 · Materials (WN = Material Number according to DIN)

| Item | Description | ASTM/AISI Material Description | | | | |
|----------------|--|--|--|-----------------------------------|---|---|
| | | Gray Iron Cast A 126 Cl.B | Carbon steel Cast A 216 WCB Forged A 105 | Carbon steel Cast A 352 LCB | Stainless steel Cast A 351 CF8M Forged A 182 F316 | Monel (WN 9.4365) / Hastelloy C (WN 9.4610) |
| 1 | Body (LC3, CF3, CF8, and others, on request) | | | | | |
| 2 | Bonnet | A 105 | | | A 182 F316 | Monel/Hastelloy C |
| 3 | Yoke, (8, 10") | A 395 (WN 0.7043) | | | | (per application) |
| 4 | Seat 1) | AISI 410 (WN 1.4006) | | AISI 316Ti (WN 1.4571) | Monel/Hastelloy C | |
| 5 | Plug 1), 2) | AISI 410 (WN 1.4006) | | AISI 316Ti (WN 1.4571) | Monel/Hastelloy C | |
| 6 | Plug stem | AISI 410 (WN 1.4006) | | AISI 316Ti (WN 1.4571) | Monel/Hastelloy C | |
| 7 | Guide bushing | AISI 430F (WN 1.4104) nitrided | | AISI 316Ti (WN 1.4571) nitr. | Monel/Hastelloy C | |
| 8 | Packing nut | AISI 316Ti (WN 1.4571) with carbon insert (guide) | | | | Monel/Hastelloy C |
| 9 | Coupling nut | AISI 430F (WN 1.4104) | | | | |
| 10 | Counter nut | AISI 430F (WN 1.4104) | | | | |
| 11 | Spring | AISI 301 (WN 1.4310) | | | | Monel/Hastelloy C |
| 12 | Washer | AISI 316Ti (WN 1.4571) | | | | Monel/Hastelloy C |
| 13 | Body stud | A 307 B | A 193 B7 | A 320 L7 | A 193 B8M Cl.2 | (per application) |
| 14 | Hex nut | A 307 B | A 193 B7 | A 194 Gr.4 | A194 8M | (per application) |
| 15 | Packing | PTFE-carbon composite (types A, B, C, H, W, and others on request) | | | | |
| 17, 39 | Gasket | Graphite laminate with AISI 316Ti (WN 1.4571) core | | | | Graph. w/Hast.C |
| 19 | Packing spacer (2.5, 3") | AISI 316Ti (WN 1.4571) | | | | Monel/Hastelloy C |
| 22 | Extension | A 105 | | A 350 LF2 | A 182 F316 | Monel/Hastelloy C |
| 24 | Guide bushing | AISI 316Ti (WN 1.4571) | | | | Hastelloy C |
| 30 | Lock washer | AISI 304 LN (WN 1.4122) | | | | Hastelloy C |
| 32 | Hex bolt | A 193 B7 | | A 320 L7 | A 193 B8M C12 | (per application) |
| 33 | Hex nut | A 193 B7 | | A 194 Gr.4 | A 194 8M | (per application) |
| 37 | Extended stem/bellows | AISI 316Ti (WN 1.4571) | | | | Hastelloy C |
| 41 | Bellows retaining nut | AISI 316Ti (WN 1.4571) | | | | Monel/Hastelloy C |
| 42 | Test connection nut | AISI 316Ti (WN 1.4571) | | | | Monel/Hastelloy C |
| 26, 80...84 | Label, indicator, bracket, screw, nameplate, rivets | AISI 304 (WN 1.4301) | | | | |

1) Seats and metal-sealing plugs also available with Stellite 6 facing; for nominal sizes ≤ 4", plugs up to SB 48 mm also available of pure Stellite 6.

Seats and plugs of Monel (WN 2.4360), Hastelloy C (WN 2.4610), hard-metal (e.g. tungsten carbide, WN 1.4112) or others on request.

2) Soft-sealed plug version, with PTFE-glass fiber composite. Pressure-balanced and versions with flow dividers, materials on request.

Table 3 · C_V and K_{Vs} values

Table 3a · Overview

| | | | | | | | | | | | | | | | | | | | | | | | |
|---------------------|------|------|------|-----|------|------|------|-----|------|-----|------|------|-----|-----|------|-----|------|-----|------|------|------|------|------|
| C _V | 0.12 | 0.2 | 0.3 | 0.5 | 0.75 | 1.2 | 2 | 3 | 5 | 7.5 | 12 | 20 | 30 | 40 | 70 | 75 | 95 | 120 | 190 | 290 | 305 | 420 | 735 |
| C _V I | - | | | | | | 1.7 | 2.6 | 4.2 | 7 | 10.5 | 17 | 26 | 36 | 62 | 67 | 85 | 105 | 170 | 265 | 275 | 375 | 650 |
| C _V III | - | | | | | | | | | | 9 | - | 23 | 30 | - | 55 | - | 140 | 220 | - | 315 | - | |
| Seat ID, Ø in | 0.12 | | 0.24 | | | 0.47 | | | 0.95 | | | 1.22 | 1.5 | 1.9 | 2.48 | | 3.15 | | 3.94 | 4.92 | 5.12 | 5.91 | 7.87 |
| Travel in | 0.6 | | | | | | | | | | | | | | | 1.2 | 0.6 | 1.2 | | 2.4 | 1.2 | 2.4 | |
| K _{Vs} | 0.1 | 0.16 | 0.25 | 0.4 | 0.63 | 1.0 | 1.6 | 2.5 | 4.0 | 6.3 | 10 | 16 | 25 | 35 | 60 | 63 | 80 | 100 | 160 | 250 | 260 | 360 | 630 |
| K _{Vs} I | - | | | | | | 1.45 | 2.2 | 3.6 | 5.7 | 9 | 14.5 | 22 | 31 | 54 | 57 | 72 | 90 | 144 | 225 | 234 | 320 | 560 |
| K _{Vs} III | - | | | | | | | | | | 7.5 | - | 20 | 26 | - | 47 | - | 120 | 190 | - | 270 | - | |
| Seat ID, Ø mm | 3 | | 6 | | | 12 | | | 24 | | | 31 | 38 | 48 | 63 | | 80 | | 100 | 125 | 130 | 150 | 200 |
| Travel mm | 15 | | | | | | | | | | | | | | | 30 | 15 | 30 | | 60 | 30 | 60 | |

Table 3b · Standard versions (without flow divider) · Versions in shadowed fields are also available with balanced valve plugs.

| | | | | | | | | | | | | | | | | | | | | | | | |
|-----------------|------|------|------|-----|------|-----|-----|-----|-----|-----|----|----|----|----|----|----|----|-----|-----|-----|-----|-----|-----|
| C _V | 0.12 | 0.2 | 0.3 | 0.5 | 0.75 | 1.2 | 2 | 3 | 5 | 7.5 | 12 | 20 | 30 | 40 | 70 | 75 | 95 | 120 | 190 | 290 | 305 | 420 | 735 |
| K _{Vs} | 0.1 | 0.16 | 0.25 | 0.4 | 0.63 | 1.0 | 1.6 | 2.5 | 4.0 | 6.3 | 10 | 16 | 25 | 35 | 60 | 63 | 80 | 100 | 160 | 250 | 260 | 360 | 630 |
| Size in mm | | | | | | | | | | | | | | | | | | | | | | | |
| 1/2 | 15 | • | • | • | • | • | • | • | • | | | | | | | | | | | | | | |
| 3/4 | 20 | • | • | • | • | • | • | • | • | • | | | | | | | | | | | | | |
| 1 | 25 | • | • | • | • | • | • | • | • | • | • | | | | | | | | | | | | |
| 1 1/2 | 40 | | | | • | • | • | • | • | • | • | • | • | | | | | | | | | | |
| 2 | 50 | | | | • | • | • | • | • | • | • | • | • | • | | | | | | | | | |
| 2 1/2 | 65 | | | | | | | | | | | | • | • | • | | | | | | | | |
| 3 | 80 | | | | | | | | | | | | • | • | • | | | | | | | | |
| 4 | 100 | | | | | | | | | | | | | | | • | | • | • | | | | |
| 6 | 150 | | | | | | | | | | | | | | | • | | • | • | | • | | |
| 8 | 200 | | | | | | | | | | | | | | | | | | | • | | • | • |
| 10 | 250 | | | | | | | | | | | | | | | | | | | • | | • | • |

Table 3c · Versions with St I flow divider (C_VI/K_{Vs}I) · Versions in shadowed fields are also available with balanced valve plugs.

| | | | | | | | | | | | | | | | | | | | | | | | |
|-------------------|-----|--|--|--|--|--|------|-----|-----|-----|------|------|----|----|----|----|----|-----|-----|-----|-----|-----|-----|
| C _V I | - | | | | | | 1.7 | 2.6 | 4.2 | 7 | 10.5 | 17 | 26 | 36 | 62 | 67 | 85 | 105 | 170 | 265 | 275 | 375 | 650 |
| K _{Vs} I | - | | | | | | 1.45 | 2.2 | 3.6 | 5.7 | 9 | 14.5 | 22 | 31 | 54 | 57 | 72 | 90 | 144 | 225 | 234 | 320 | 560 |
| Size in mm | | | | | | | | | | | | | | | | | | | | | | | |
| 1/2 | 15 | | | | | | • | • | • | | | | | | | | | | | | | | |
| 3/4 | 20 | | | | | | • | • | • | | | | | | | | | | | | | | |
| 1 | 25 | | | | | | • | • | • | | | | | | | | | | | | | | |
| 1 1/2 | 40 | | | | | | | | | • | • | • | • | | | | | | | | | | |
| 2 | 50 | | | | | | | | | • | • | • | • | • | | | | | | | | | |
| 2 1/2 | 65 | | | | | | | | | | | | • | • | • | | | | | | | | |
| 3 | 80 | | | | | | | | | | | | • | • | • | | | | | | | | |
| 4 | 100 | | | | | | | | | | | | | | | • | | • | • | | | | |
| 6 | 150 | | | | | | | | | | | | | | | • | | • | • | | • | | |
| 8 | 200 | | | | | | | | | | | | | | | | | | | • | | • | • |
| 10 | 250 | | | | | | | | | | | | | | | | | | | • | | • | • |

Table 3d · Versions with St III flow divider (C_VIII/K_{Vs}III) · Versions in shadowed fields are also available with balanced valve plugs.

| | | | | | | | | | | | | | | | | | | | | | | | |
|---------------------|-----|--|--|--|--|--|--|--|--|---|-----|---|----|----|---|----|---|---|-----|-----|---|-----|---|
| C _V III | - | | | | | | | | | | 9 | - | 23 | 30 | - | 55 | - | - | 140 | 220 | - | 315 | - |
| K _{Vs} III | - | | | | | | | | | | 7.5 | - | 20 | 26 | - | 47 | - | - | 120 | 190 | - | 270 | - |
| Size in mm | | | | | | | | | | | | | | | | | | | | | | | |
| 1/2 | 15 | | | | | | | | | | | | | | | | | | | | | | |
| 3/4 | 20 | | | | | | | | | | | | | | | | | | | | | | |
| 1 | 25 | | | | | | | | | | | | | | | | | | | | | | |
| 1 1/2 | 40 | | | | | | | | | | | | | | | | | | | | | | |
| 2 | 50 | | | | | | | | | • | | | | | | | | | | | | | |
| 2 1/2 | 65 | | | | | | | | | | | | • | • | | | | | | | | | |
| 3 | 80 | | | | | | | | | | | | • | • | | | | | | | | | |
| 4 | 100 | | | | | | | | | | | | | | | • | | | | | | | |
| 6 | 150 | | | | | | | | | | | | | | | • | | | | | | | |
| 8 | 200 | | | | | | | | | | | | | | | | | | | • | | • | • |
| 10 | 250 | | | | | | | | | | | | | | | | | | | • | | • | • |

Table 4 · Differential pressure tables · Unbalanced valve plugs

Values specified in the shadowed columns correspond to the standard application, i.e. to rated travel · Differential pressures specified in the white columns apply to maximum pre-stressed springs (max. bench setting range).

Differential pressures enclosed in parentheses refer to mid-travel position.

Observe the notes on the differential pressure tables, listed on page 2.

Table 4a · Permissible differential pressures Δp · Pressures in psi

For actuators employing fail-safe action: Actuator “extends” stem · Valve closed at supply pressure 0 psi

| Bench range (psi) for actuators with effective area (in ²): | | 37 | | 3...15 | 4...17 | | 6...30 (18...30) | - | 9...33 | | 13...48 | | - | - | | |
|--|-------------|----------------|-------------|-----------------|-----------------|----------|---------------------|--------------------------------|---------|---------|----------------------|----------------------|-----|-------|-------|-----|
| | | 18.5, 54, 108 | 217 | | 6...18 | 7...36 | | | 12...36 | 18...52 | 20...34 (26...34) | 30...48 (39...50) | | | | |
| | | 434 | - | - | 12...18 | - | 30...45 | 23...35 | - | 34...52 | 15...45 | - | - | - | | |
| Required supply pressure (psi) | | 18 | 21 | 33 | 39 | 38 | 47 | 55 | 47 | 38 | 55 | | | | | |
| DN | | C _v | | K _{vs} | | Actuator | | Δp with p ₂ = 0 psi | | | | | | | | |
| in | mm | | | in ² | cm ² | | | | | | | | | | | |
| ½" | 15 to 25 | 0.12 to 0.3 | 0.1 to 0.25 | 18.5 | 120 | 320 | - | 580 | - | - | - | - | - | - | | |
| | | | | 37 | 240 | 580 | 580 | - | - | - | - | - | - | | | |
| ½" | 15 to 50 | 0.5 to 1.2 | 0.4 to 1.0 | 18.5 | 120 | 320 | - | 580 | - | - | - | - | - | - | | |
| | | | | 37 | 240 | 580 | 580 | 580 | - | - | - | - | - | - | | |
| | | | | 2 | 1.6 | 18.5 | 120 | 130 | - | 405 | - | - | - | - | 580 | - |
| | | | | 3 | 2.5 | 37 | 240 | 406 | 580 | 580 | - | 580 | 580 | 580 | - | - |
| | 5 | 4 | 54 | 350 | 580 | 580 | 580 | - | 580 | 580 | - | - | 580 | - | | |
| ¾" | 20 to 50 | 7.5 | 6.3 | 18.5 | 120 | - | - | 80 | - | - | - | - | - | 435 | 580 | |
| | | | | 37 | 240 | 75 | 135 | 215 | - | 350 | 350 | 565 | - | - | - | |
| | | | | 54 | 350 | 145 | 350 | 350 | - | 550 | 550 | 580 | - | - | 580 | 580 |
| | | | | 108 | 700 | 350 | - | (580) | - | - | - | - | - | - | - | - |
| 1½" | 40 and 50 | 20 | 16 | 18.5 | 120 | - | - | 44 | - | - | - | - | - | 260 | 405 | |
| | | | | 37 | 240 | 36 | 75 | 115 | - | 200 | 200 | 335 | - | - | - | |
| | | | | 54 | 350 | 75 | 195 | 195 | - | 435 | 320 | 580 | - | - | 580 | 580 |
| | | | | 108 | 700 | 195 | - | (580) | - | - | (580) | - | - | - | - | - |
| 1½" | 40 to 80 | 30 | 25 | 18.5 | 120 | - | - | 22 | - | - | - | - | - | 175 | 275 | |
| | | | | 37 | 240 | 19 | 45 | 72 | - | 130 | 130 | 218 | - | - | - | |
| | | | | 54 | 350 | 45 | 125 | 125 | - | 290 | 200 | 450 | - | - | 535 | 580 |
| | | | | 108 | 700 | 126 | - | (580) | - | - | (580) | - | - | - | - | - |
| 2" | 50 to 80 | 40 | 35 | 37 | 240 | - | - | 43 | - | 72 | 72 | 130 | - | - | - | |
| | | | | 54 | 350 | 23 | 72 | 72 | - | 175 | 123 | 275 | - | 330 | 507 | |
| | | | | 108 | 700 | 72 | - | (580) | - | - | (580) | - | - | - | - | - |
| 2½" | 65 and 80 | 70 | 60 | 37 | 240 | - | - | 20 | - | 40 | 40 | 72 | - | - | - | |
| | | | | 54 | 350 | 12 | 39 | 39 | - | 94 | 65 | 152 | - | 190 | 290 | |
| | | | | 108 | 700 | 39 | - | (333) | - | - | (507) | - | - | (520) | (580) | |
| 3" | 80 | 95 | 80 | 37 | 240 | - | - | 9 | - | 22 | 22 | 40 | - | - | - | |
| | | | | 54 | 350 | - | 20 | 20 | - | 58 | 339 | 94 | - | 115 | 174 | |
| | | | | 108 | 700 | 20 | - | 20 | - | - | (305) | - | - | (320) | (475) | |
| 4" | 100 | 75 | 63 | 108 | 700 | 38 | 94 | 94 | - | 217 | 152 | 333 | - | 390 | 580 | |
| | | | | 120 | 100 | 20 | 58 | 58 | - | 130 | 94 | 203 | - | 239 | 362 | |
| 4", 6" | 100, 150 | 190 | 160 | 108 | 700 | 10 | 33 | 33 | - | 80 | 58 | 123 | - | 152 | 225 | |
| | | | | 150 | 305 | 260 | 108 | 700 | 4.4 | 17 | 17 | - | 43 | 32 | 85 | - |
| 8" and 10" | 200 and 250 | 290 | 250 | 217 | 1400 | - | 49 | 49 | 64 | 110 | - | - | 139 | - | - | |
| | | | | 434 | 2800 | - | 230 | - | 580 | 470 | - | 580 | - | - | - | |
| | | 420 | 360 | 217 | 1400 | - | 33 | 33 | 43 | 74 | - | - | 95 | - | - | |
| | | | | 434 | 2800 | - | 157 | - | 410 | 325 | - | 490 | - | - | - | |
| | | 735 | 630 | 217 | 1400 | - | - | - | 23 | 41 | - | - | 52 | - | - | |
| | | | | 434 | 2800 | - | 87 | - | 229 | 181 | - | 276 | - | - | - | |

1) Not for actuator with effective area 18.5" (120 cm²)

Table 4b · Permissible differential pressures Δp · Pressures in bar

For actuators employing fail-safe action: Actuator "extends" stem · Valve fully closed at supply pressure 0 bar

| Bench range (bar) | | 240 | | 0.2...1.0 | 0.3...1.1 | 0.4...2.0 (1.2...2.0) | - | 0.6...2.2 | 0.6...3.0 ¹⁾ (1.8...3.0) | 0.9...3.3 | - | - | - | | |
|---|-------------|-----------------|-----------------|-----------------|-----------------|--|-----------|-----------|--|---------------------------|------|--------------------------|-----|------|--|
| | | 120,350, 700 | 0.4...1.2 | | 0.8...2.4 | | | 1.2...3.6 | | 1.4...2.3 (1.85...2.3) | | 2.1...3.3 (2.7...3.3) | | | |
| for actuators with effective area (cm ²): | | 1400 | - | - | - | 0.5...2.5 | 2.0...3.0 | 1.6...2.4 | - | 1.0...3.0 | - | - | - | | |
| | | 2800 | 0.8...1.2 | - | - | 2.0...3.0 | 1.6...2.4 | - | 2.4...3.6 | - | - | - | - | | |
| Required supply pressure (bar) | | | | 1.2 | 1.4 | 2.2 | 2.7 | 2.6 | 3.2 | 3.8 | 3.2 | 2.5 | 3.5 | | |
| Size | | C _v | K _{vs} | Actuator | | Δp with p ₂ = 0 bar | | | | | | | | | |
| in | mm | | | in ² | cm ² | | | | | | | | | | |
| ½" to 1" | 15 to 25 | 0.12 to 0.3 | 0.1 to 0.25 | 18.5 | 120 | 40 | - | 40 | - | - | - | - | - | | |
| | | | | 37 | 240 | 40 | 40 | - | - | - | - | - | - | | |
| ½" to 2" | 15 to 50 | 0.5 to 1.2 | 0.4 to 1.0 | 18.5 | 120 | 22 | - | 40 | - | - | - | - | - | | |
| | | | | 37 | 240 | 40 | 40 | 40 | - | - | - | - | - | | |
| | | 2 | 1.6 | 18.5 | 120 | 9 | - | 28 | - | - | - | - | 40 | | |
| | | 3 | 2.5 | 37 | 240 | 28 | 40 | 40 | - | 40 | 40 | 40 | - | - | |
| | 5 | 4 | 54 | 350 | 40 | 40 | 40 | - | 40 | 40 | - | - | 40 | | |
| ¾" to 2" | 20 to 50 | 7.5 | 6.3 | 18.5 | 18.5 | - | - | 5.5 | - | - | - | - | 30 | | |
| | | | | 37 | 240 | 5.2 | 9.3 | 14.8 | - | 24 | 24 | 39 | - | - | |
| | | 12 | 10 | 54 | 350 | 10 | 24 | 24 | - | 38 | 38 | 40 | - | 40 | |
| | | | | 108 | 700 | 24 | - | (40) | - | - | - | - | - | | |
| 1½" and 2" | 40 and 50 | 20 | 16 | 18.5 | 120 | - | - | 3 | - | - | - | - | 18 | | |
| | | | | 37 | 240 | 2.5 | 5.2 | 8.0 | - | 14 | 14 | 23 | - | - | |
| | | | | 54 | 350 | 5.2 | 13.5 | 13.5 | - | 30 | 22 | 40 | - | 40 | |
| | | | | 108 | 700 | 13.5 | - | (40) | - | - | (40) | - | - | - | |
| 1½" to 3" | 40 to 80 | 30 | 25 | 18.5 | 120 | - | - | 1.5 | - | - | - | - | 12 | | |
| | | | | 37 | 240 | 1.3 | 3.1 | 5.0 | - | 9.0 | 9.0 | 15 | - | - | |
| | | | | 54 | 350 | 3.1 | 8.5 | 8.5 | - | 20 | 14 | 31 | - | 37 | |
| | | | | 108 | 700 | 8.7 | - | (40) | - | - | (40) | - | - | - | |
| 2" to 3" | 50 to 80 | 40 | 35 | 37 | 240 | - | - | 3.0 | - | 5.0 | 5.0 | 9.0 | - | | |
| | | | | 54 | 350 | 1.6 | 5.0 | 5.0 | - | 12 | 8.5 | 19 | - | 23 | |
| | | | | 108 | 700 | 5.0 | - | (40) | - | - | (40) | - | - | - | |
| 2½" and 3" | 65 and 80 | 70 | 60 | 37 | 240 | - | - | 1.4 | - | 2.8 | 2.8 | 5.0 | - | | |
| | | | | 54 | 350 | 0.8 | 2.7 | 2.7 | - | 6.5 | 4.5 | 10.5 | - | 13 | |
| | | | | 108 | 700 | 2.7 | - | (23) | - | - | (35) | - | - | (36) | |
| 3" | 80 | 95 | 80 | 37 | 240 | - | - | 0.6 | - | 1.5 | 1.5 | 2.8 | - | | |
| | | | | 54 | 350 | - | 1.4 | 1.4 | - | 4.0 | 2.7 | 6.5 | - | 8 | |
| | | | | 108 | 700 | 1.4 | - | 1.4 | - | - | (21) | - | - | (22) | |
| 4" | 100 | 75 | 63 | 108 | 700 | 2.6 | 6.5 | 6.5 | - | 15 | 10.5 | 23 | - | | |
| 4" | 100 | 120 | 100 | 108 | 700 | 1.4 | 4.0 | 4.0 | - | 9.0 | 6.5 | 14 | - | | |
| 4", 6" | 100, 150 | 190 | 160 | 108 | 700 | 0.7 | 2.3 | 2.3 | - | 5.5 | 4.0 | 8.5 | - | | |
| 6" | 150 | 305 | 260 | 108 | 700 | 0.3 | 1.2 | 1.2 | - | 3.0 | 2.2 | 6.0 | - | | |
| 8" and 10" | 200 and 250 | 290 | 250 | 217 | 1400 | - | 3.4 | 3.4 | 4.4 | 7.5 | - | - | 9.6 | | |
| | | | | 434 | 2800 | - | 15.8 | - | 40 | 32.4 | - | 40 | - | - | |
| | | 420 | 360 | 217 | 1400 | - | 2.3 | 2.3 | 3.0 | 5.1 | - | - | 6.6 | | |
| | | | | 434 | 2800 | - | 10.8 | - | 28.2 | 22.4 | - | 33.9 | - | - | |
| | | 735 | 630 | 217 | 1400 | - | - | - | 1.6 | 2.8 | - | - | 3.6 | | |
| | | | | 434 | 2800 | - | 6 | - | 15.8 | 12.5 | - | 19 | - | - | |

¹⁾ Not for actuator with effective area 120 cm² (18.5 in²)

Table 4c · Permissible differential pressures Δp

For actuators employing fail-safe action: Actuator "retracts" stem · Valve closed at required supply pressure

| | | | | | | Table 4c · Pressures in psi | | | | |
|---|-------------------|-------------------|-------------------|-----------------|-----------------|--|-----|-----|-----|---|
| Bench range (bar/psi) for actuators with effective area (in ²): | | 18.5 ... 434 | | | | 3 ... 15 | | | | |
| | | 217 | | | | (6 ... 30) | | | | |
| | | 434 | | | | (4 ... 15) | | | | |
| Required supply pressure (bar/psi) | | | | | | 18 | 36 | 58 | | |
| Size | | C _v | K _{vs} | Actuator | | Δp with p ₂ = 0 psi | | | | |
| in | mm | | | in ² | cm ² | | | | | |
| 1/2" to 1" | 15 to 25 | 0.12 to 0.3 | 0.1 to 0.25 | 18.5 | 120 | 330 | 580 | – | | |
| | | | | 37 | 240 | 580 | – | – | | |
| 1/2" to 2" | 15 to 50 | 0.3 to 1.2 | 0.4 to 1.0 | 18.5 | 120 | 330 | 580 | – | | |
| | | | | 37 | 240 | 580 | 580 | – | | |
| | | | | 2 | 1.6 | 18.5 | 120 | 130 | 580 | – |
| | | | | 3 | 2.5 | 37 | 240 | 410 | 580 | – |
| | | | | 5 | 4 | 54 | 350 | 580 | 580 | – |
| 3/4" to 2" | 20 to 50 | 7.5 | 6.3 | 18.5 | 120 | 10 | 450 | 580 | | |
| | | | | 37 | 240 | 80 | 580 | 580 | | |
| | | | | 54 | 350 | 145 | 580 | 580 | | |
| | | | | 108 | 700 | 350 | 580 | – | | |
| 1 1/2" and 2" | 40 and 50 | 20 | 16 | 18.5 | 120 | – | 260 | 580 | | |
| | | | | 37 | 240 | 35 | 540 | 580 | | |
| | | | | 54 | 350 | 75 | 580 | 580 | | |
| | | | | 108 | 700 | 200 | 580 | – | | |
| 1 1/2" to 3" | 40 to 80 | 30 | 25 | 18.5 | 120 | – | 160 | 410 | | |
| | | | | 37 | 240 | 20 | 350 | 580 | | |
| | | | | 54 | 350 | 45 | 540 | 580 | | |
| | | | | 108 | 700 | 130 | 580 | 580 | | |
| 2" to 3" | 50 to 80 | 40 | 35 | 37 | 240 | 10 | 220 | 490 | | |
| | | | | 54 | 350 | 25 | 330 | 580 | | |
| | | | | 108 | 700 | 75 | 580 | 580 | | |
| 2 1/2" and 3" | 65 and 80 | 70 | 60 | 37 | 240 | – | 120 | 290 | | |
| | | | | 54 | 350 | 10 | 190 | 420 | | |
| | | | | 108 | 700 | 40 | 390 | 580 | | |
| 3" | 80 | 95 | 80 | 37 | 240 | – | 75 | 170 | | |
| | | | | 54 | 350 | 5 | 110 | 260 | | |
| | | | | 108 | 700 | 20 | 230 | 540 | | |
| 4" | 100 | 75 | 63 | 108 | 700 | 40 | 390 | 580 | | |
| 4" | 100 | 120 | 100 | 108 | 700 | 20 | 230 | 520 | | |
| 4" and 6" | 100 and 150 | 190 | 160 | 108 | 700 | 10 | 145 | 330 | | |
| 6" | 150 | 305 | 260 | 108 | 700 | 5 | 85 | 200 | | |
| 8" and 10" | 200 and 250 | 290 | 250 | 217 | 1400 | 20 | 200 | 440 | | |
| | | | | 434 | 2800 | 50 | 410 | 580 | | |
| | | 420 | 360 | 217 | 1400 | – | 140 | 300 | | |
| | | | | 434 | 2800 | 35 | 280 | 580 | | |
| | | 735 | 630 | 217 | 1400 | – | 75 | 170 | | |
| | | | | 434 | 2800 | – | 160 | 350 | | |

Tables 4d · Permissible differential pressures Δp

For actuators employing fail-safe action: Actuator "retracts" stem · Valve closed at required supply pressure

| | | | | | | Table 4d · Pressures in bar | | | | |
|---|-------------------|-------------------|-------------------|-----------------|-----------------|--|------|------|------|------|
| Bench range (bar/psi) for actuators with effective area (cm ²): | | 120 ... 2800 | | | | 0.2 ... 1.0 | | | | |
| | | 1400 | | | | (0.4 ... 2.0) | | | | |
| | | 2800 | | | | (0.3 ... 1.0) | | | | |
| Required supply pressure (bar/psi) | | | | | | 1.2 | 2.4 | 4 | | |
| Size | | C _v | K _{vs} | Actuator | | Δp with p ₂ = 0 bar | | | | |
| in | mm | | | in ² | cm ² | | | | | |
| ½" | 15 to 25 | 0.12 to 0.3 | 0.1 to 0.25 | 18.5 | 120 | 23 | 40 | - | | |
| | | | | 37 | 240 | 40 | - | - | | |
| ½" | 15 to 50 | 0.3 to 1.2 | 0.4 to 1.0 | 18.5 | 120 | 23 | 40 | - | | |
| | | | | 37 | 240 | 40 | 40 | - | | |
| | | | | 2 | 1.6 | 18.5 | 120 | 9 | 40 | - |
| | | | | 3 | 2.5 | 37 | 240 | 28 | 40 | - |
| | | | | 54 | 350 | 40 | 40 | - | | |
| ¾" | 20 to 50 | 7.5 | 6.3 | 18.5 | 120 | 0.6 | 31 | 40 | | |
| | | | | 37 | 240 | 5.2 | 40 | 40 | | |
| | | | | 54 | 350 | 10 | 40 | 40 | | |
| | | | | 108 | 700 | 24 | 40 | - | | |
| 1½" | 40 and 50 | 20 | 16 | 18.5 | 120 | - | 18 | 40 | | |
| | | | | 37 | 240 | 2.5 | 37 | 40 | | |
| | | | | 54 | 350 | 5.2 | 40 | 40 | | |
| | | | | 108 | 700 | 13.5 | 40 | - | | |
| 1½" | 40 to 80 | 30 | 25 | 18.5 | 120 | - | 11 | 28 | | |
| | | | | 37 | 240 | 1.3 | 24 | 40 | | |
| | | | | 54 | 350 | 3.1 | 37 | 40 | | |
| | | | | 108 | 700 | 8.7 | 40 | 40 | | |
| 2" | 50 to 80 | 40 | 35 | 37 | 240 | 0.5 | 15 | 34 | | |
| | | | | 54 | 350 | 1.6 | 23 | 40 | | |
| | | | | 108 | 700 | 5.0 | 40 | 40 | | |
| 2½" | 65 and 80 | 70 | 60 | 37 | 240 | - | 8.5 | 20 | | |
| | | | | 54 | 350 | 0.6 | 13 | 29 | | |
| | | | | 108 | 700 | 2.7 | 27 | 40 | | |
| 3" | 80 | 95 | 80 | 37 | 240 | - | 5.0 | 12 | | |
| | | | | 54 | 350 | 0.2 | 7.8 | 18 | | |
| | | | | 108 | 700 | 1.4 | 16 | 37 | | |
| 4" | 100 | 75 | 63 | 108 | 700 | 2.6 | 27 | 40 | | |
| 4" | 100 | 120 | 100 | 108 | 700 | 1.4 | 16 | 36 | | |
| 4" and 6" | 100 and 150 | 190 | 160 | 108 | 700 | 0.7 | 10 | 23 | | |
| 6" | 150 | 305 | 260 | 108 | 700 | 0.3 | 6.0 | 13.5 | | |
| | | | | 290 | 250 | 217 | 1400 | 1.3 | 13.7 | 30.3 |
| | | | | | | 434 | 2800 | 3.4 | 28.3 | 40 |
| | | | | 420 | 360 | 217 | 1400 | - | 9.5 | 21.0 |
| | | | | | | 434 | 2800 | 2.3 | 19.5 | 40 |
| | | | | 735 | 630 | 217 | 1400 | - | 5.2 | 11.7 |
| 434 | 2800 | - | 10.9 | | | 23.9 | | | | |

Table 5 · Differential pressure tables · Balanced valve plugs with PTFE balancing seal (without bellows)

Values specified in the shadowed columns correspond to the standard application, i.e. to rated travel · Differential pressures specified in the white columns apply to maximum pre-stressed springs (max. bench setting range).

Fail-safe action: Actuator “extends” stem · Valve closed at supply pressure 0 psi (0 bar)

Fail-safe action: Actuator “retracts” stem · Valve closed at required supply pressure

Tables 5a and 5b · Permissible differential pressures Δp · Pressures in psi

| Table 5a · Actuator “extends” stem | | | | | | Table 5b · Stem “retracts” | | | | | | |
|------------------------------------|-----|-------|----------|-----------------|-----------------|-------------------------------|---------|--------|--------|--------|-----|-----|
| Bench range | | psi | | 3...15 | 6...18 | 6...30 | 12...36 | 3...15 | 3...15 | 6...30 | | |
| Required supply pressure | | psi | | 18 | 21 | 33 | 39 | 18 | 18 | 33 | | |
| Size | | C_v | K_{vs} | Actuator | | Δp with $p_2 = 0$ psi | | | | | | |
| in | mm | | | in ² | cm ² | | | | | | | |
| 2½" | 65 | 70 | 60 | 54 | 350 | – | 580 | 580 | 580 | – | 580 | 580 |
| 3" | 80 | | | 108 | 700 | 580 | 580 | – | – | 580 | – | – |
| 3" | 80 | 95 | 80 | 54 | 350 | – | 580 | 580 | 580 | – | 580 | 580 |
| | | | | 108 | 700 | 580 | 580 | – | – | 580 | – | – |
| 4" | 100 | 75 | 63 | 108 | 700 | 440 | 580 | 580 | 580 | 440 | 580 | 580 |
| 4" | 100 | 190 | 160 | 108 | 700 | – | 580 | 580 | 580 | 170 | 580 | 580 |
| 6" | 150 | | | | | – | 580 | 580 | 580 | – | 580 | 580 |
| 6" | 150 | 305 | 260 | 108 | 700 | – | 580 | 580 | 580 | – | 580 | 580 |

Tables 5c and 5d · Permissible differential pressures Δp · Pressures in bar

| Table 5c · Actuator “extends” stem | | | | | | Table 5d · Stem “retracts” | | | | | | |
|------------------------------------|-----|-------|----------|-----------------|-----------------|-------------------------------|-----------|-----------|-----------|-----------|----|----|
| Bench range | | bar | | 0.2...1.0 | 0.4...1.2 | 0.4...2.0 | 0.8...2.4 | 0.2...1.0 | 0.2...1.0 | 0.4...2.0 | | |
| Required supply pressure | | bar | | 1.2 | 1.4 | 2.2 | 2.6 | 1.2 | 2.0 | 3.0 | | |
| Size | | C_v | K_{vs} | Actuator | | Δp with $p_2 = 0$ bar | | | | | | |
| in | mm | | | in ² | cm ² | | | | | | | |
| 2½" | 65 | 70 | 60 | 54 | 350 | – | 40 | 40 | 40 | – | 40 | 40 |
| 3" | 80 | | | 108 | 105 | 40 | 40 | – | – | 40 | – | – |
| 3" | 80 | 95 | 80 | 54 | 350 | – | 40 | 40 | 40 | – | 40 | 40 |
| | | | | 108 | 700 | 40 | 40 | – | – | 40 | – | – |
| 4" | 100 | 75 | 63 | 108 | 700 | 30 | 40 | 40 | 40 | 30 | 40 | 40 |
| 4" | 100 | 190 | 160 | 108 | 700 | – | 40 | 40 | 40 | 12 | 40 | 40 |
| 6" | 150 | | | | | – | 40 | 40 | 40 | – | 40 | 40 |
| 6" | 150 | 305 | 260 | 108 | 700 | – | 40 | 40 | 40 | – | 40 | 40 |

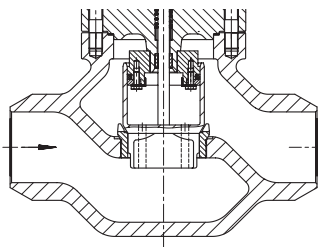

Fig. 9 · Version with pressure-balanced plug and bonnet

Table 6 · Differential pressure tables · Balanced valve plugs with PTFE balancing seal with metal bellows seal

Values specified in the shadowed columns correspond to the standard application, i.e. to rated travel · Differential pressures specified in the white columns apply to maximum pre-stressed springs (max. bench setting range).

Differential pressures enclosed in parentheses refer to mid-travel position.

Fail-safe action: Actuator “extends” stem · Valve closed at supply pressure 0 psi (0 bar)

Fail-safe action: Actuator “retracts” stem · Valve closed at required supply pressure

Tables 6a and 6b · Permissible differential pressures Δp · Pressures in psi

| Table 6a · Actuator “extends” stem | | | | | | | | | | | Table 6b · Stem “retracts” | | | |
|------------------------------------|-----|-------|----------|-----------------|---------------------|-------------------------------|--------|---------|--------|--------|----------------------------|-----|-----|-----|
| Bench range | | psi | 3...15 | 6...18 | 6...30 (18...30) | 12...36 | 9...45 | 18...52 | 3...15 | 6...30 | 9...45 | | | |
| Required supply pressure | | psi | 18 | 21 | 33 | 39 | 48 | 55 | 18 | 44 | 60 | | | |
| Size | | C_v | K_{vs} | Actuator | | Δp with $p_2 = 0$ psi | | | | | | | | |
| in | mm | | | in ² | cm ² | | | | | | | | | |
| 2½" | 65 | 70 | 60 | 54 | 350 | - | 250 | 250 | 580 | 520 | 580 | - | - | 580 |
| 3" | 80 | | | 108 | 700 | 250 | 580 | (580) | - | - | - | 250 | 580 | - |
| 3" | 80 | 95 | 80 | 54 | 350 | - | 170 | 174 | 580 | 450 | 580 | - | - | 580 |
| | | | | 108 | 700 | 170 | 580 | (580) | - | - | - | 170 | 580 | - |
| 4" | 100 | 75 | 63 | 108 | 700 | 75 | 250 | 250 | 580 | 440 | 580 | 75 | - | 580 |
| 4" | 100 | 190 | 160 | 108 | 700 | - | 200 | 200 | 550 | 380 | 580 | 20 | - | 540 |
| 6" | 150 | | | | | - | 160 | 160 | 510 | 330 | 580 | - | - | 580 |

Tables 6c and 6d · Permissible differential pressures Δp · Pressures in bar

| Table 6c · Actuator “extends” stem | | | | | | | | | | | Table 6d · Stem “retracts” | | | |
|------------------------------------|-----|-------|-----------|-----------------|------------------------|-------------------------------|-----------|-----------|-----------|-----------|----------------------------|-----|----|----|
| Bench range | | bar | 0.2...1.0 | 0.4...1.2 | 0.4...2.0 (1.2...2) | 0.8...2.4 | 0.6...3.0 | 1.2...3.6 | 0.2...1.0 | 0.4...2.0 | 0.6...3.0 | | | |
| Required supply pressure | | bar | 1.2 | 1.4 | 2.2 | 2.6 | 3.2 | 3.8 | 1.2 | 3.0 | 4.0 | | | |
| Size | | C_v | K_{vs} | Actuator | | Δp with $p_2 = 0$ bar | | | | | | | | |
| in | mm | | | in ² | cm ² | | | | | | | | | |
| 2½" | 65 | 70 | 60 | 54 | 350 | - | 17 | 17 | 40 | 36 | 40 | - | - | 40 |
| 3" | 80 | | | 108 | 700 | 17 | 40 | (40) | - | - | - | 17 | 40 | - |
| 3" | 80 | 95 | 80 | 54 | 350 | - | 12 | 12 | 40 | 31 | 40 | - | - | 40 |
| | | | | 108 | 700 | 12 | 40 | (40) | - | - | - | 12 | 40 | - |
| 4" | 100 | 75 | 63 | 108 | 700 | 5.0 | 17 | 17 | 40 | 30 | 40 | 5.0 | - | 40 |
| 4" | 100 | 190 | 160 | 108 | 700 | - | 14 | 14 | 38 | 26 | 40 | 1.5 | - | 40 |
| 6" | 150 | | | | | - | 11 | 11 | 35 | 23 | 40 | - | - | 40 |

Table 7a · Dimensions of the standard versions in inches

| Globe valve | Size | in | 1/2" | 3/4" | 1" | 1 1/2" | 2" | 2 1/2" | 3" | 4" | 6" | 8" | 10" |
|---|-----------------------|-----|------|------|------|--------|-------|--------|-------|-------|-------|-------|-------|
| | | NPT | 1/2 | 3/4 | 1 | 1 1/2 | 2 | - | | | | | |
| Length L | 125/150 | in | 7.25 | 7.25 | 7.25 | 8.75 | 10.0 | 10.87 | 11.75 | 13.87 | 17.75 | 21.38 | 26.5 |
| | Class 300 | in | 7.50 | 7.62 | 7.75 | 9.25 | 10.50 | 11.50 | 12.50 | 14.50 | 18.62 | 22.38 | 27.88 |
| Length L1 | Class 250 | in | 6 | 6 | 6 | 8 | 9.25 | - | | | | | |
| H1 actuators with effective area: | ≤ 700 cm ² | in | 8.6 | | | | 10.2 | | 13.8 | 15.3 | - | | |
| | 1400 cm ² | in | - | | | | - | | - | | | 31.7 | |
| | 2800 cm ² | in | - | | | | - | | - | | | 41.7 | |
| H2 (approximately) | | in | 1.8 | | 2.8 | | 3.8 | | 4.5 | 6.9 | 9.3 | 10.2 | |
| H2 (approx.), forged steel | | in | 2.1 | - | 2.7 | 3.6 | 3.8 | - | 5.0 | - | | | |

| | | | | | | | |
|---|-----------------|------------|---------|---------|------|------------|-----------|
| Pneumatic actuator | Size | 120 | 240 | 350 | 700 | 1400 | 2800 |
| | in ² | 18.5 | 37 | 54 | 108 | 217 | 434 |
| Diaphragm Ø D | in | 6.6 | 9.5 | 11.0 | 15.4 | 20.9 | 30.3 |
| H | in | 2.7 | 2.6 | 3.4 | 5.3 | 11.3 | 19.5 |
| H3 ¹⁾ | in | 4.3 | | 7.5 | | 24.0 | 25.5 |
| Thread | | M 30 x 1.5 | | | | M 60 x 1.5 | M 100 x 2 |
| α (for Type 3271 Actuator) ²⁾ | | NPT 1/8 | NPT 1/4 | NPT 3/8 | | NPT 1/2 | NPT 1 |
| α2 (for Type 3277 Actuator) ²⁾ | | - | NPT 3/8 | | | - | |

¹⁾ Minimum clearance for actuator disassembly (for both Types 3271 and 3277)

²⁾ ISO G (straight) thread also available, on request

Table 8a · Weights in lbs

| Globe valve | Size | inch | 1/2" | 3/4" | 1" | 1 1/2" | 2" | 2 1/2" | 3" | 4" | 6" | 8" | 10" |
|--------------------------|-----------------|------|------|------|------|--------|------|--------|----|----|-----|-----|-----|
| Weight, without actuator | | lbs | 11 | 13 | 15 | 26 | 33 | 53 | 66 | 92 | 264 | 728 | 840 |
| Pneumatic actuator | Size | 120 | 240 | 350 | 700 | 1400 | 2800 | | | | | | |
| | in ² | 18.5 | 37 | 54 | 108 | 217 | 434 | | | | | | |
| Weight of Type 271 | lbs | 6.6 | 11 | 18 | 48.5 | 154 | 990 | | | | | | |
| Weight of Type 3277 | lbs | 7.7 | 20 | 26.5 | 57.5 | - | | | | | | | |

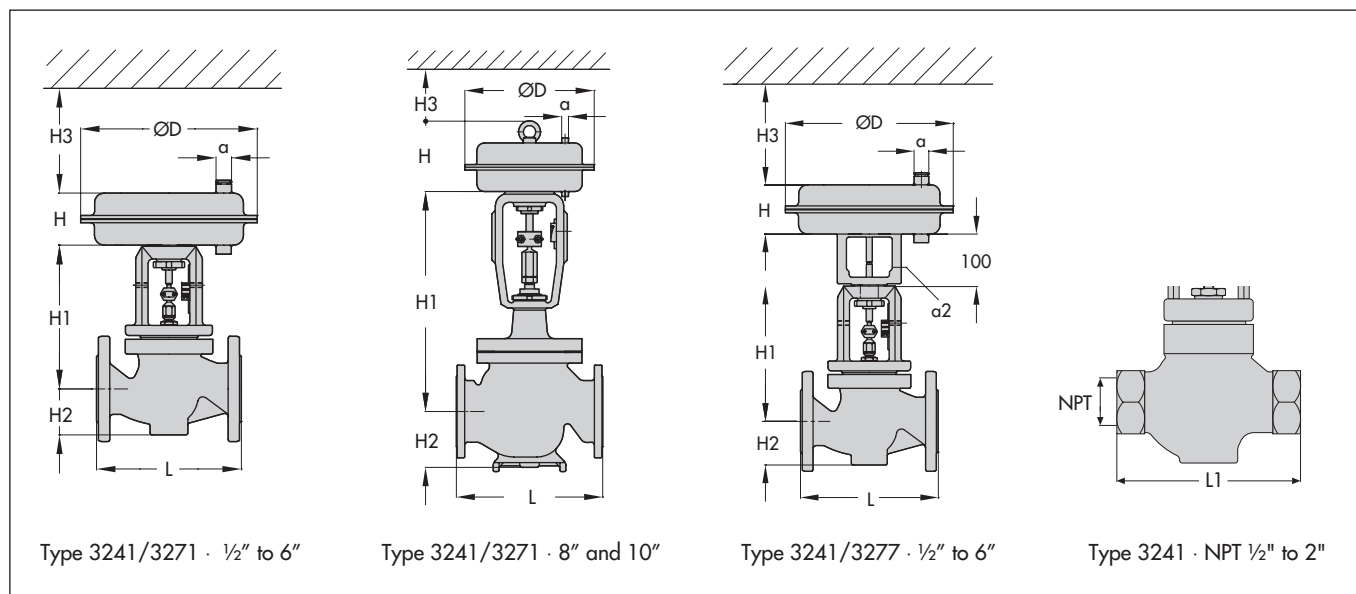

Table 7b · Dimensions of the standard versions in mm

| Globe valve | Size | in | 1/2" | 3/4" | 1" | 1 1/2" | 2" | 2 1/2" | 3" | 4" | 6" | 8" | 10" |
|---|-----------------------|-----|-------|-------|-------|--------|-----|--------|-----|-----|------|-----|-----|
| | | mm | 15 | 20 | 25 | 40 | 50 | 65 | 80 | 100 | 150 | 200 | 250 |
| | | NPT | 1/2 | 3/4 | 1 | 1 1/2 | 2 | - | | | | | |
| Length L | 125/150 | mm | 184 | 184 | 184 | 222 | 254 | 276 | 298 | 352 | 451 | 543 | 673 |
| | Class 300 | mm | 191 | 194 | 197 | 235 | 267 | 292 | 318 | 368 | 473 | 568 | 708 |
| Length L1 | Class 250 | mm | 152.4 | 152.4 | 152.4 | 203.2 | 235 | - | | | | | |
| H1 actuators with effective area: | ≤ 700 cm ² | mm | 220 | | | | 260 | | 350 | 390 | - | | |
| | 1400 cm ² | mm | - | | | | - | | | | 805 | | |
| | 2800 cm ² | mm | - | | | | - | | | | 1060 | | |
| H2 (approximately) | | mm | 45 | | | 72 | | 98 | | 113 | 175 | 235 | 260 |
| H2 (approx.) forged steel | | mm | 53 | - | 70 | 92 | 98 | - | 128 | - | | | |

| | | | | | | | |
|--------------------------------|-----------------|------------|---------|---------|-----|------------|-----------|
| Pneumatic actuator | cm ² | 120 | 240 | 350 | 700 | 1400 | 2800 |
| Diaphragm Ø D | mm | 168 | 240 | 280 | 390 | 530 | 770 |
| H | mm | 69 | 65 | 85 | 134 | 287 | 620 |
| H3 1) | mm | 110 | | | 190 | 610 | 648 |
| Thread | | M 30 x 1.5 | | | | M 60 x 1.5 | M 100 x 2 |
| a (for Type 3271 Actuator) 2) | | NPT 1/8 | NPT 1/4 | NPT 3/8 | | NPT 1/2 | NPT 1 |
| a2 (for Type 3277 Actuator) 2) | | - | NPT 3/8 | | | - | |

1) Minimum clearance for actuator disassembly (for both Types 3271 and 3277)

2) ISO G (straight) thread also available, on request

Table 8b · Weights in kg

| Globe valve | Size | in | 1/2" | 3/4" | 1" | 1 1/2" | 2" | 2 1/2" | 3" | 4" | 6" | 8" | 10" |
|--------------------------|-----------------|-----|------|------|-----|--------|------|--------|----|-----|-----|-----|-----|
| | | mm | 15 | 20 | 25 | 40 | 50 | 65 | 80 | 100 | 150 | 200 | 250 |
| Weight, without actuator | kg | 5 | 6 | 7 | 12 | 15 | 24 | 30 | 42 | 120 | 330 | 380 | |
| Pneumatic actuator | cm ² | 120 | 240 | 350 | 700 | 1400 | 2800 | | | | | | |
| Weight of Type 3271 | kg | 3 | 5 | 8 | 22 | 70 | 450 | | | | | | |
| Weight of Type 3277 | kg | 3.5 | 9 | 12 | 26 | - | | | | | | | |

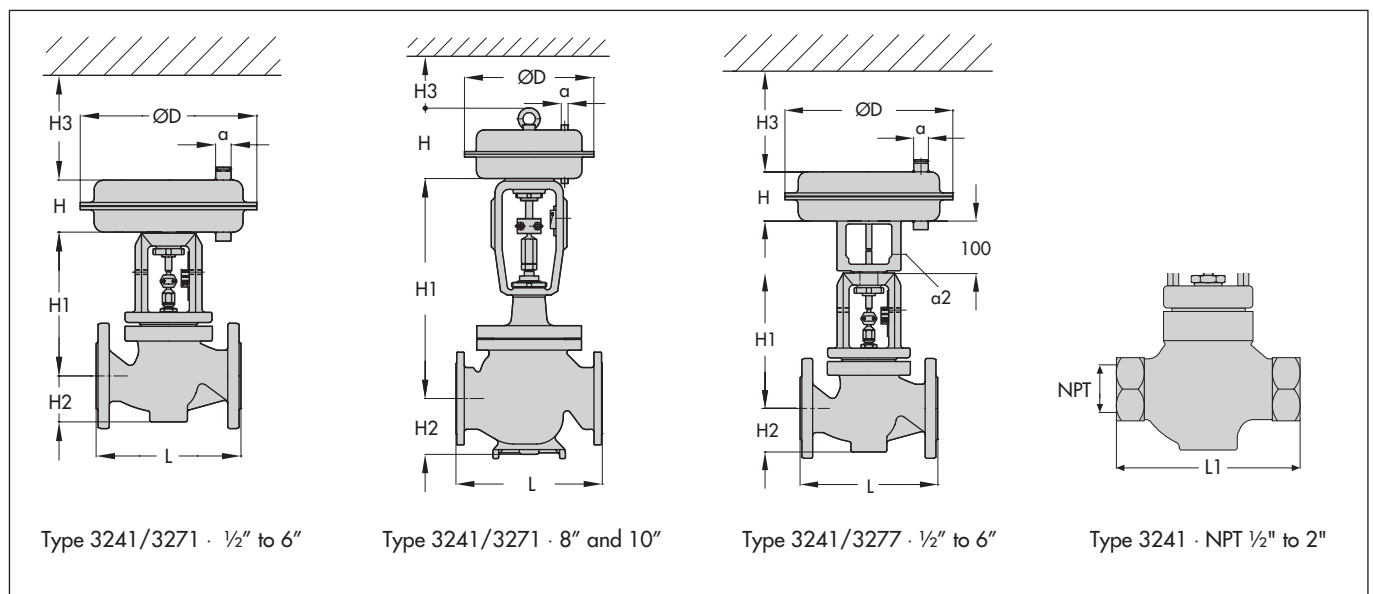

Table 9 · Dimensions and weights of special versions with insulating section or metal bellows seal · (without actuator)

Table 9a · Nominal sizes ½" to 6" and NPT ½" to 2" in inches and lbs

| Globe valve | Size/NPT in | ½" | ¾" | 1" | 1½" | 2" | 2½" | 3" | 4" | 6" |
|--------------------|--------------------------------|------|----|----|------|----|------|----|------|------|
| Height H4 | Short insul. or bell. sect. in | 15.9 | | | 15.5 | | 17.1 | | 25 | 25.8 |
| | Long. insul. or bell. sect. in | 27.9 | | | 27.9 | | 29.1 | | 34.5 | 35.2 |
| Approximate weight | lbs | 18 | 20 | 22 | 40 | 46 | 71 | 84 | 132 | 330 |

Table 9b · Nominal sizes 8" and 10" in inches and lbs

| Version with | | Insulating section | | Metal bellows section | |
|---|-----------------|--------------------|------|-----------------------|------|
| Pneumatic actuator | Size | 1400 | 2800 | 1400 | 2800 |
| | in ² | 217 | 434 | 217 | 434 |
| H4 for nom. sizes 8", 10" in | | 49.2 | 58.3 | 57.2 | 66.4 |
| Approximate weight in lbs for nominal sizes | 8" | 840 | 885 | 860 | 905 |
| | 10" | 950 | 995 | 970 | 1015 |

Table 9c · Nominal sizes ½" to 6" and NPT ½" to 2" in mm and kg

| Globe valve | Size/NPT in | ½" | ¾" | 1" | 1½" | 2" | 2½" | 3" | 4" | 6" |
|--------------------|--------------------------------|-----|----|----|-----|----|-----|----|-----|-----|
| | mm | 15 | 20 | 25 | 40 | 50 | 65 | 80 | 100 | 150 |
| Height H4 | Short insul. or bell. sect. mm | 405 | | | 395 | | 435 | | 635 | 655 |
| | Long. insul. or bell. sect. mm | 710 | | | 710 | | 740 | | 875 | 895 |
| Approximate weight | kg | 8 | 9 | 10 | 18 | 21 | 32 | 38 | 60 | 150 |

Table 9d · Nominal sizes 8" and 10" in mm and kg

| Version with | | Insulating section | | Metal bellows section | |
|--|-----------------|--------------------|------|-----------------------|------|
| Pneumatic actuator | cm ² | 1400 | 2800 | 1400 | 2800 |
| H4 for sizes 200, 250 | mm | 1250 | 1480 | 1453 | 1687 |
| Approximate weight in kg for nominal sizes | 200 | 380 | 400 | 390 | 410 |
| | 250 | 430 | 450 | 440 | 460 |

Dimensions and weights of versions with heating jacket are available on request.

Type 3241 (241) Globe Valve with insulating section or metal bellows seal

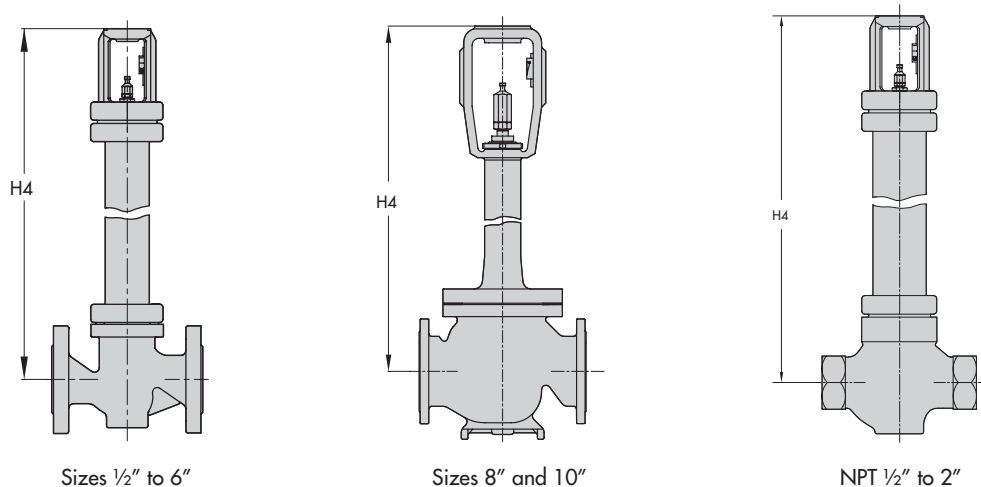

Pressure-Temperature Diagram

According to ASME/ANSI B16.34, Cast Iron according to B16.1 (Flanged) and B16.4 (NPT)

For reference only. For exact values, consult the respective ANSI standard.

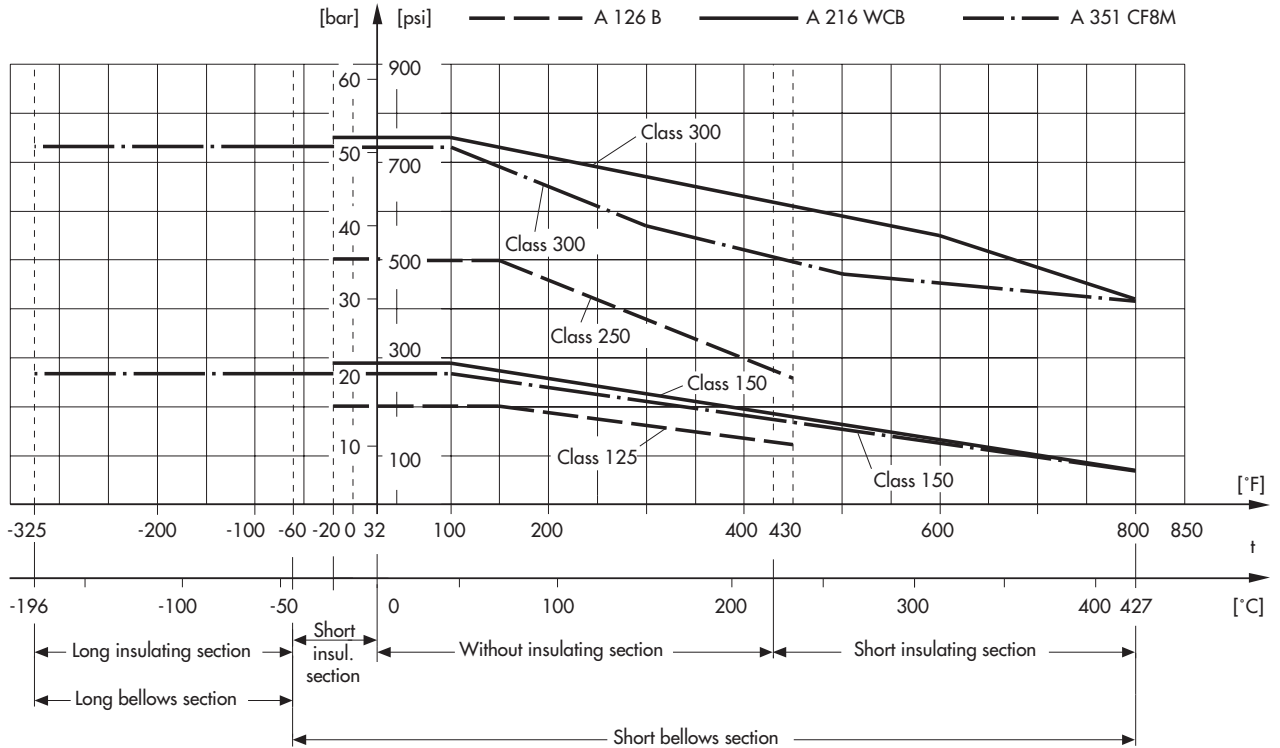

Installation

Arbitrary mounting orientation. If the mounting orientation is inclined, the actuator and valve must be supported. Observe the clearance is adequate to allow actuator, bonnet and plug removal (H3 in the table of dimensions). Direction of flow as indicated by the arrow on the valve body

Registered Trade Marks

Monel, Hastelloy, and Stellite are referred to within this publication with the understanding that the names are Registered Trade Marks of their respective owners, which include Cabot Wrought Products, International Nickel Co., Carpenter Technology, or the rightful owner, in the past as well as in future cases.

Ordering information

Globe Control Valve Type 3241 (241):

Nominal valve size¹⁾ ...
Body material ASTM ...
Pressure rating ANSI Class ...
C_v-/K_vs-value¹⁾ ... Characteristic ...
Options/Special version ...
Special testing/preparation ...

Actuator:

Type ... Ordering information⁵⁾ ...
Fail-safe position ...

Operating conditions²⁾:

Process fluid³⁾ ... Flow rate⁴⁾ ...
Inlet pressure ... Outlet pressure⁴⁾ ...
Temperature ...
Maximum shutoff Δp for actuator sizing ...
Air/power supply available for actuator, max./min. ...

Accessories:

Positioner, Switches, Transmitter, Solenoid valve, Filter/regulator,
Bypass, Volume/pressure amplifier, Lockup relay ...
Type ... Ordering information⁵⁾ ...
Tubing and fittings type/material ...

Other instrumentation:

Controllers, Sensors, Transmitters, Transducers, Converters ...
Type ... Ordering information⁵⁾ ...

Notes:

- ¹⁾ If nominal size or C_v-/K_vs-value unknown, specify operating conditions
- ²⁾ Specify system of units, pressures: specify gauge or absolute. Provide minimum, normal, and maximum values, where applicable. Gases, vapors: specify flow rate under standard or actual conditions
- ³⁾ Non-standard process fluids, specify additionally: Density, Specific gravity, or Molecular weight ... Liquids: Vapor pressure, Critical pressure, Viscosity ... Gases, Vapors: Ratio of specific heats, Compressibility factor
- ⁴⁾ Or, specify required valve flow coefficient C_v, K_vs ...
- ⁵⁾ Ordering information per the applicable Technical Data Sheet.

Specifications subject to change without notice.



SAMSON CONTROLS INC.
1 - 105 Riviera Drive
Markham · Ontario · Canada · L3R 5J7
Tel. (905) 474-0354 · Telefax (905) 474-0998

SAMSON CONTROLS INC.
4111 Cedar Boulevard
Baytown · Texas · USA · 77520-8588
Tel. (281) 383-3677 · Telefax (281) 383-3690

T 8012

T 8012 CA